

Supercal 5S

Static Heat- and Cooling Meter
DN 15 - DN 500



Your benefits

- Fluid oscillation principle:
High stability and repeatability for a longterm and accurate measurement, even with poor water quality
- No moving parts:
Not sensitive to dirt, air bubbles and liquids with changing viscosity
- No straight section necessary up to DN40 and only 3 DN necessary for DN50 and up:
High flexibility in building planning
- Rugged and durable calculator:
Particularly rugged construction of the casing and the mechanical and electrical connections
- NFC Interface:
For a simplified and user-friendly calculator configuration on site

Applications

- High-end device for building management
- All applications in district heating and cooling or building automation
- Optimally suited for glycol and other mixtures
- As a replacement for mechanical impeller heat meters

Properties

- Exchangeable measuring head
- Common spare parts from q_p 1 up to 1500 m³/h
- Complete range of pipes q_p 1 - 1500 m³/h
- Dynamic flow range:
1 : 100 at q_p 1 - 25 m³/h
1 : 50 at q_p 40 - 400 m³/h
1 : 25 at q_p 800 - 1500 m³/h
- Protection class of flow sensor IP68
- For horizontal, up- and downstream pipes, threaded and flange fittings
- Direct pick-up of voltage pulses without reflectors
- Self-cleaning effect due to the fluid oscillating characteristic
- Corrosion resistant materials without moving parts (no wear)
- Temperature sensor Pt 500 (2- or 4-wires)
- Exchangeable calculator electronics while wiring remains in place
- Large, illuminated dot-matrix display (128 x 64 pixel)
- Freely configurable tariff and data logger functions (up to 2'175 entries)
- Battery (12+1-year) or mains powered for increased flexibility
- Integrated backup battery for metrological part
- Standard EN 1434 class 2
- **CE** Conformity according European Measuring Instruments Directive (MID) or Conformity according to the Directive Measurement Canada

Options

- Up to 2 option cards can be retrofitted, either Ex-Factory or on site, or replaced at any time without affecting the approval of the calculator:
 - M-Bus according to EN 13757
 - BACnet MS/TP (RS485) / Modbus (RS485) – requires mains supply
 - 2 Analogue outputs, 0-20 mA, 4-20 mA, 0(2)-10 V DC – requires mains supply

Technical Data

Volume measuring meter			Threaded connection, G ¾" - G 2" (DN 15 - 40)						
Nominal diameter	DN	mm	15	20	15	20	25	40	
Operating pressure	PN	bar	16 or 25						
Connection thread on meter	G...A	Inch	¾	1	¾	1	1¼	2	
Connection thread on coupling	R...	Inch	½	¾	½	¾	1	1½	
Nominal flow rate	q _p	m ³ /h	1	1.5	2.5	3.5	6	10	
Maximum flow rate	q _s	m ³ /h	2	3	5	7	12	20	
Minimum flow rate	q _i	l/h	10	15	25	35	60	100	
Low flow threshold value		l/h	4	10	15	30	50		
Kvs value		m ³ /h	2.09	2.06	5.44	5.21	7.46	13.4	20.9
Pressure loss at q _p		bar	0.20	0.25	0.09	0.25	0.16	0.25	
Maximum temperature		°C	130						
Standard measuring range	q _i /q _p		1:100						
Material			Brass						
Standard			EN ISO 228-1						

Dimensions								
Length without couplings	L	mm	110	190	110	190	260	300
Total height	H	mm	79				105	122
Meter depth	D	mm	125				78	
Meter weight		kg	2.9	3.2	2.9	3.2	3.5	4.5
Figure Number			1				2	

Volume measuring meter			ANSI-Flanged connection, NPS 2 - NPS 8						
Nominal pipe size	NPS	inch	2	2½	3	4	5	6	8
Class			150						
Nominal flow rate	q _p	m ³ /h	15	25	40	60	100	150	250
Maximum flow rate	q _s	m ³ /h	30	50	80	120	200	300	500
Minimum flow rate	q _i	l/h	150	250	800	1200	2000	3000	5000
Low flow threshold value		l/h	75	125	400	600	1000	1500	2500
Kvs value		m ³ /h	31.6	51.8	142	210	343	514	857
Pressure loss at q _p		bar	0.25	0.09	0.10				
Maximum temperature		°C	130						
Standard measuring range	q _i /q _p		1:100			1:50			
Material			Spheroidal cast iron						Stainless steel
Standard			ASME B16.42-2016						ASME B16.5-2003

Dimensions										
Length	L	mm	270	300		360	250	300	350	
Total height	H	mm	167	190	210	233	258	283	NA	
Meter depth	D	mm	150	180	190	230	255	280	298.5	
Øk	Øk	mm	120.7	139.7	152.4	190.5	215.9	241.3	298.5	
Bolts			4				8			
Meter weight		kg	9.8	NA	15.7	17.1	17.4	27.6	NA	
Figure Number			3							

Volume measuring meter			DIN-Flanged connection, DN25 - 150, Material: Brass or Spheroidal cast iron									
Nominal diameter	NPS	mm	25	25	40	50	65	80	100	125	150	
Operating pressure	PN	bar	16 or 25						16			
Nominal flow rate	q_p	m³/h	3.5	6	10	15	25	40	60	100	150	
Maximum flow rate	q _s	m ³ /h	7	12	20	30	50	80	120	200	300	
Minimum flow rate	q _i	l/h	35	60	100	150	250	800	1200	2000	3000	
Low flow threshold value		l/h	15	30	50	75	125	400	600	1000	1500	
Kvs value		m ³ /h	7.46	13.4	20.9	31.6	51.8	142	210	343	514	
Pressure loss at q _p		bar	0.16			0.25		0.09	0.1			
Maximum temperature		°C	130									
Standard measuring range	q _i /q _p		1:100					1:50				
Material			Brass				Spheroidal cast iron					
Standard			DIN-EN 1092-1 / DIN 2501 / ISO 7005-3				DIN-EN 1092-1 / DIN 2501 / ISO 7005-1					

Dimensions										
Length	L	mm	260	300	270	300		360	250	300
Total height	H	mm	134	157	171	189	203	226	254	286
Meter depth	D	mm	115	150	165	185	200	220	250	285
Øk	Øk	mm	85	110	125	145	160	180	210	240
Bolts			4 (M12)	4 (M16)		8 (M16)				8 (M20)
Meter weight		kg	5.4	8.1	9.1	11.2	13.1	19	16	27.2
Figure Number			3							

Volume measuring meter			DIN-Flanged connection, DN 50 - DN 250, Material: Stainless steel or Steel																		
Nominal diameter	DN	mm	50	65	80	100			125		150		200		250		350		500		
Operating pressure	PN	bar	16 or 25			16	25	16	25	16	25	16	25	16	25	16	25	10	16	10	16
Nominal flow rate	q_p	m ³ /h	15	25	40	60			100		150		250		400		800		1500		
Maximum flow rate	q_s	m ³ /h	30	50	80	120			200		300		500		800		1600		3000		
Minimum flow rate	q_i	l/h	150	250	800	1200			2000		3000		5000		8000		32000		60000		
Low flow threshold value		l/h	75	125	400	600			1000		1500		2500		4000		16000		30000		
Kvs value		m ³ /h	31,6	51,8	142	210			343		514		857		1372		2667		5000		
Pressure loss at q_p		bar	0,25		0,09		0,10														
Maximum temperature		°C	130																		
Standard measuring range	q_i/q_p		1:100			1:50						1:25									
Material			Stainless steel																		
Standard			DIN-EN 1092-1 / DIN 2501 / ISO 7005-1																		

Dimensions																					
Length	L	mm	270	300	225	300	250	360	250	360	250	300	500	300	500	350	450	500			
Total height	H	mm	171	189	203	226	235	254	270	286	300	340	360	405	425	505	520	670	715		
Meter depth	D	mm	165	185	200	220	235	250	270	285	300	340	360	405	425	505	520	670	715		
Øk	Øk	mm	125	145	160	180	190	210	220	240	250	295	310	355	370	460	470	620	650		
Bolts (M)			4 M16	8 M16			8 M20	8 M16	8 M24	8 M20	8 M24	M20	12 M24	12 M27	16 M20	16 M24	16 M24	20 M30			
Meter weight		kg	9,1	11,2	14,4	13,1	14	19	14	19	16	27,2	23	27,2	23	30	38,1	90	105	130	195
Figure Number			3																		

Dimension Diagram

Figure 1

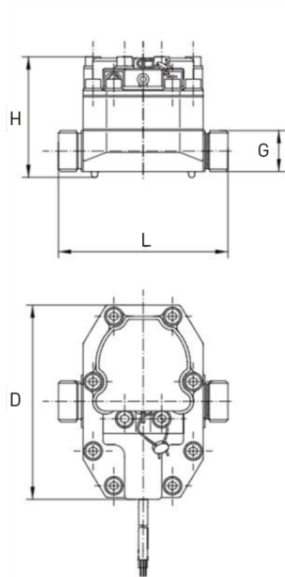

Figure 2

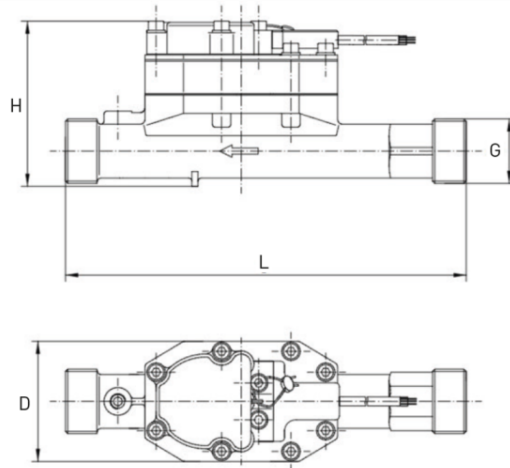
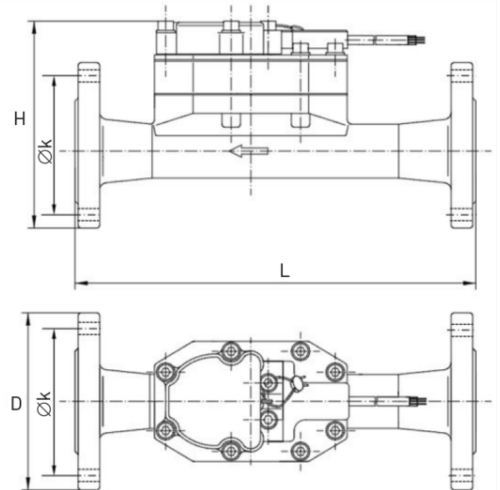
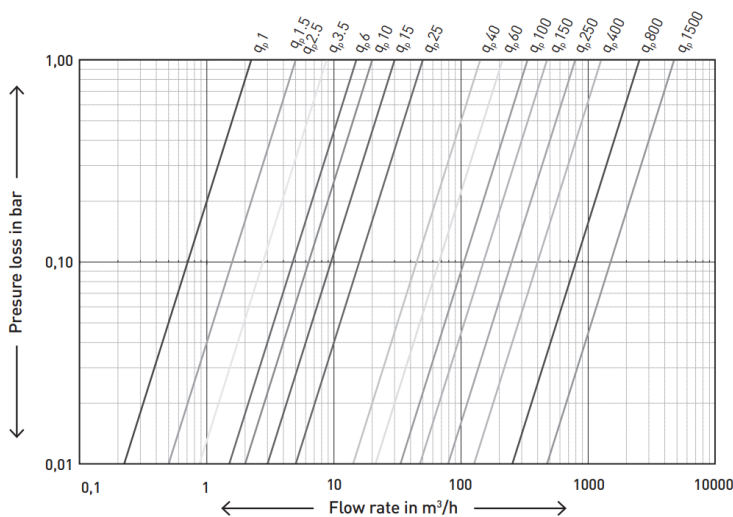

Figure 3



Typical Head Loss Curve



Calculator

Calculator	
Dimensions (HxWxD)	162 x 143 x 54 mm
Environment class C	E1/M1
Temperature sensor type	2- or 4-wire, Pt 500
Absolute temperature range	-20 °C to 200 °C
Approved temperature range	1 °C to 200 °C
Absolute temperature difference	1 K to 150 K
Homologation temperature difference	3 K to 150 K
Response limit	0.2 K
Temperature resolution t (display)	0.1 °C
Temperature resolution Δt (display)	0.01 K
Measurement accuracy	Better than requirements according to EN1434-1
Measuring cycle temperature measurement - Battery operated (D-cell) - Mains operated	10 s to 30 s (depends on flow rate) 3 s to 30 s (depends on flow rate)
Ambient temperature in operation	5 °C to 55 °C
Transport and storage temperature	-20 °C to 70 °C (dry environment)
Ambient humidity	<93% relative humidity
Display	Illuminated (if mains powered) dotmatrix display (128 x 64 pixel)
Display units	9 digits, MWh, m ³ , °C, K
Additional pulse inputs	Energy or volume
Protection class	IP65 in accordance to IEC 60529
Power supply options	Battery D-cell (12+1-year lifetime) OR Mains, 100-240 V AC, 50/60 Hz OR Mains, 12-42 V DC or 12-36 V AC
2 additional pulse inputs	Max. 200 Hz, 0-30 V DC
2 open collector pulse outputs	Max. 200 Hz, 0-30 V DC
Optical Interface	According to IEC 62056-21:2002
NFC Interface	According to ISO/IEC 14443 Type A
M-Bus Interface	According to EN 13757-2/3 Baudrate: 300 to 9'600 Bit/s 1 M-Bus standard unit load (1,5 mA)

Temperature sensor

Sensor element	Pt 500
Connection diagram	2- or 4-wire
Installation length	Depends on meter size

Flow sensor

Approved temperature range	5 °C to 130 °C
Environment temperature	5 °C to 55 °C
Storage temperature	-25 °C to 70 °C
Protection class	IP68

Installation

Pipeline:	horizontal	—
	vertical	
Meter head (for horizontal installation):	+/- 45°	↔

The principle of fluid oscillator flow sensor

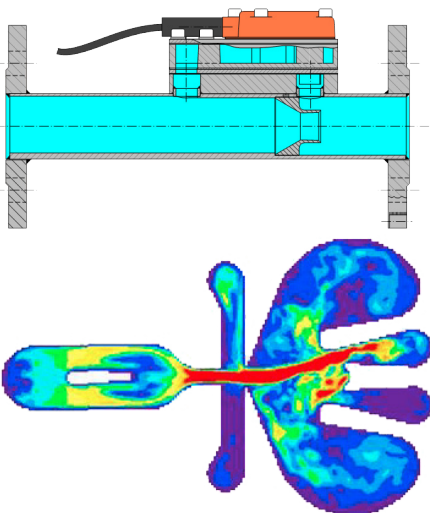

The main part of the flow passes through a Venturi nozzle in the pipe, creating the differential pressure to bypass the other part of the flow through the fluid oscillator.

In the oscillator the liquid is led to a nozzle and accelerated to a jet. Opposite of the nozzle the jet is redirected to the left or right into a channel that leads upwards to the sensor head equipped with a piezo sensor. The pressure of the liquid on the sensor creates an electrical pulse. The liquid flows back to the pipe through a return loop and redirects the jet into the other channel where the action is repeated and fluid oscillation is created. The frequency of this oscillation is linear proportional to the volume flow. A supplementary benefit is the self cleaning effect due to the oscillating character.

The animated top view on the oscillator shows the differences of velocity of the liquid. The jet accelerated by the nozzle with the highest velocity in red, slow velocity in blue.