



Q-Heat 5.5 US (CAN)

Thermal energy meter



Your benefits

- Ultrasonic technology:
Long-term stable energy measurement with highest measurement accuracy
- Compact design:
Little installation space required on site
- Flexible installation:
 - **Change of flow and return flow**
 - **Change of the energy unit**
 - **Removable calculator (compact/split)**
- Large measuring range:
up for detection of smallest flow rates
- User-friendly:
Parameter setting directly via the device buttons
- Operational reliability:
Display of operating faults

Applications

- High-end device in the building technology sector
- Replacement of mechanical impeller heat meters
- Heat and/or cold consumption measurement in the building technology sector

Properties

- Ultrasonic heat and cold meter (combi meter)
- Nominal diameter DN15 to DN40
- Nominal flow $q_{p1.5}$ to q_{p10}
- Battery life up to 15 years (depending on environment and configuration conditions)
- Maximum operating pressure PN 16 bar
- Temperature range 5 – 90 °C
- Compact design and removable calculator as standard for tight and difficult to access installation situations
- Any installation position without restrictions, even "overhead"
- LCD-Resolution 8 digits
- Display in kWh, MWh, MJ, GJ possible
- Temperature sensor pt 1000

Options

- Measurement Canada-compliant ultrasonic compact heat meter
- Standard Version with M-Bus interface (powered by battery)
- Retrofittable with external LoRaWAN radio module (RCM-H200 FW-V $\geq 1.9.18$)

Technical data

Ambient conditions

Protection rating	Calculator unit: IP65 according to EN 60529 Flow sensor: IP65 according to EN 60529
Transport	-25°C ... 70°C, 95% r.h. (without condensation)
Storage	-5°C ... 45°C, 95% r.h. (without condensation)
Usage	+5°C ... 55°C, 95% r.h. (without condensation)
Medium	Only use water without chemical additives as the medium for this device. Glycol additives or sodium chloride NaCl (common salt) are expressly not permitted!

Standards

Interference resistance and interference emission	EN 301 489-1, EN 301 489-3
Security	EN 62368-1, EN 62479
Quality of the heating medium	according to VDI guideline 2035, AGFW standard 510

Influencing quantities

Electromagnetic class	E1
Mechanical class	M2
Ambient class	A
Measuring accuracy class	2

Calculator unit Temperature range

Temperature range	0°C ... 105°C
Temperature difference range	3K ... 70K
Start of metering temperature difference	0.2K

Power supply

Lithium battery	Nominal voltage 3.0 V
Lithium content	0.58g
Battery type	CR AA
Batteries per device	1 (replaceable)
Battery life	Up to 15 years (depending on environment and configuration conditions)

Display-levels

Display	8-digit LCD + pictograms
Energy display (switchable)	Default (kWh) kWh -> MWh MJ -> GJ kWh -> MJ (only up to 50 liters of cumulative flow) MWh -> GJ (only up to 50 liters of cumulative flow)
Connecting cable Calculator - volume measuring unit	80 cm

Technical data communication

Connection cable	OUT
Function	M-Bus
Length	3 m
Within Scope of delivery	included
Protection class	IP65
Cable ends	End sleeves
Cable sheathing	PVC

Connection cable - Colour assignment

M-Bus	red black orange (not assigned) brown (not assigned)
M-Bus to RCM-H200 connection	red -> brown (ECO+) black -> white (ECO-) orange -> green (ECO Modem) Brown -> (not assigned)

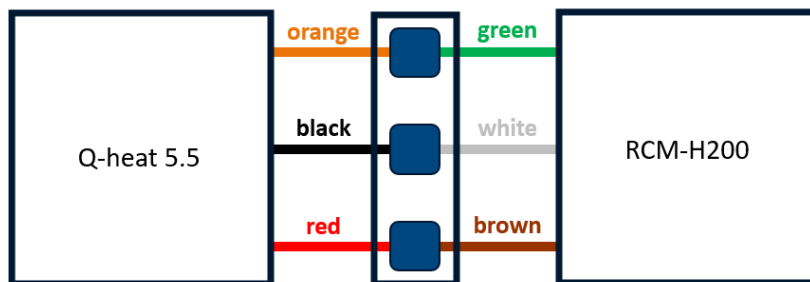

Specifications M-Bus

Possible readouts per day	96 (every 15 minutes) ²
Baud rate	300, 2400 (default)

² if readings are taken less frequently, unused "credits" are stored in the device

Technical data temperature sensor

Temperature sensor	
Measuring element	Pt1000 according to EN 60751
Type	Typ DS
Diameter Ø	AGFW - 6.0 mm
Installation variant	q _p 1.5-2.5 q _p 3.5-10
	AGFW 27.5 mm – direct installation Asymmetric 6.0 mm - indirect symmetrical (immersion sleeve)
Cable length	Default: 1.5m Optional: 3.0m

Technical data flow sensor

Flow sensor						
Nominal flow q _p	m ³ /h	1,5	2,5	3,5	6	10
Nominal diameter DN	mm	15	20	25	25	40
Overall length	mm	110	130	260	260	300
Connection		G¾B	G1B	G1¼B	G1¼B	G2B
Weight	g	530	660	1173	1173	1750
Installation location		Return or forward flow (switchable up to 50 litres cumulative flow)				
Installation position		any				
Inlet and outlet section		not required (no downstream or upstream straight pipe requirement)				
Minimum flow q _i	l/h	15	25	28	48	100
Maximum flow q _s	l/h	3000	5000	7000	12000	20000
Start-up limit q ₀	l/h	6	10	14	24	50
Dynamic range		1:100	1:100	1:125	1:125	1:100
Accuracy class		2	2	2	2	2
Pressure loss at q _p	mbar	130	180	38	122	168
Max. permissible operating pressure	bar	16				
Min. system pressure to avoid cavitation	bar	1,5	2	1	1,5	1,5
temperature range	°C	5 ... 90				

Dimensional drawings

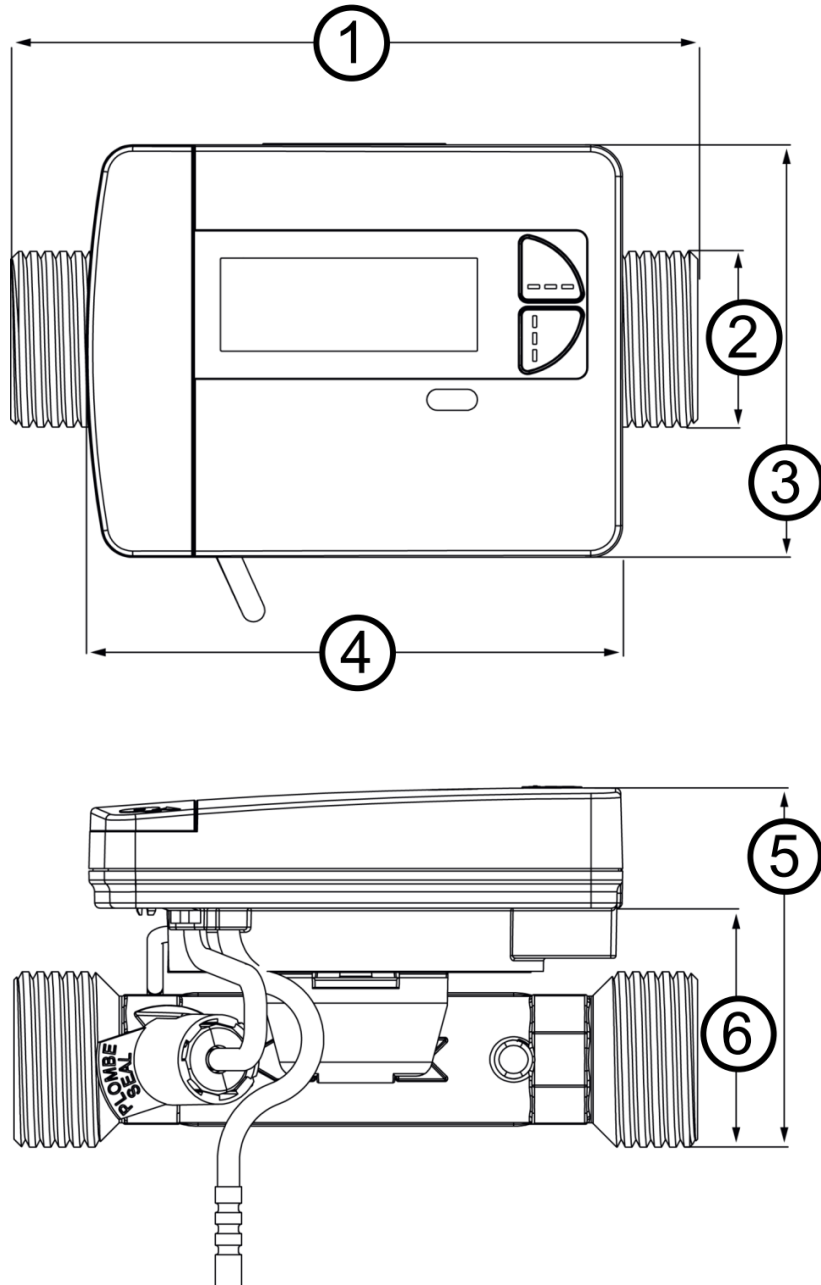

Dimensions

Nominal flow q_p	m^3/h	1,5	2,5	3,5	6	10
1 Pipe length	mm	110	130	260	260	300
2 Threads		G $3/4$ B	G1B	G1 $1/4$ B	G1 $1/4$ B	G2B
3 Calculator width	mm	78				
4 Calculator length	mm	101,5				
5 Total height	mm	65	68,48	84	84	100
6 Height of volume measuring part	mm	41,5	45	60,5	60,5	76,5