



Axonic

Ultrasonic volume measuring meter



Your benefits

- Robust, high grade wear resistant materials:
Excellent measuring stability and reliability
- Outstanding metrological properties:
Increased cost effectiveness
- Universal applicable with diverse calculators:
Meets various requirements also with regard to interfaces
- Integrated intelligence (status and warning messages):
Simple and quick on-site troubleshooting

Applications

- As a replacement for mechanical impeller heat meters
- Metering of heat and/or cooling consumption in building management

Properties

- Universal installation position
- Maximum operating pressure PN 16 bar / PN 25 bar
- Temperature up to 130 °C
- Rotatable hinged flanges
- 2D-Barcode with Serial No. and meter details
- **CE** Conformity according to European Measuring Instruments Directive (MID)
- Pulser with 3 m cable
(Standard pulse value: DN 65–100: 10 liters, DN 150: 100 liters)
- Environmental class C, Accuracy class 2

Options

- Pulser with 10 m cable

Technical Data

Execution			AXONIC							
Nominal diameter	DN	mm	65	65	80	80	100	100	150	150
Operating pressure	PN	bar	16	25	16	25	16	25	16	25
Nominal flow rate	q _p	m ³ /h	25	25	40	40	60	60	150	150
Maximum flow rate	q _s	m ³ /h	50	50	80	80	120	120	300	300
Minimum flow rate	q _i	m ³ /h	0.1	0.1	0.16	0.16	0.24	0.24	0.6	0.6
Starting flow		ca. m ³ /h	0.04	0.04	0.08	0.08	0.1	0.1	0.3	0.3
Kvs-value		m ³ /h	80	80	110	97	160	160	390	390
Temperature range		°C	1...130	1...130	1...130	1...130	1...130	1...130	1...130	1...130
Measuring range	q _i /q _p		1:250	1:250	1:250	1:250	1:250	1:250	1:250	1:250

Dimensions and weights			AXONIC							
Length	L	mm	200	300	225	300	360 ¹⁾	360	500 ²⁾	500
Height	H	mm	204	204	209	209	219	219	244	244
Height	h	mm	93	93	100	100	111	118	143	150
Flange external dimension	D	mm	185	185	200	200	220	235	240	250
Hole circle diameter	L	mm	145	145	160	160	180	190	240	250
Number of screws		Stk.	4	8	8	8	8	8	8	8
Weight		ca. kg	8	9	9.6	10.4	14	16	28	31

1) Also supplied in length 250 mm 2) Also supplied in length 300 mm

Dimension Diagram

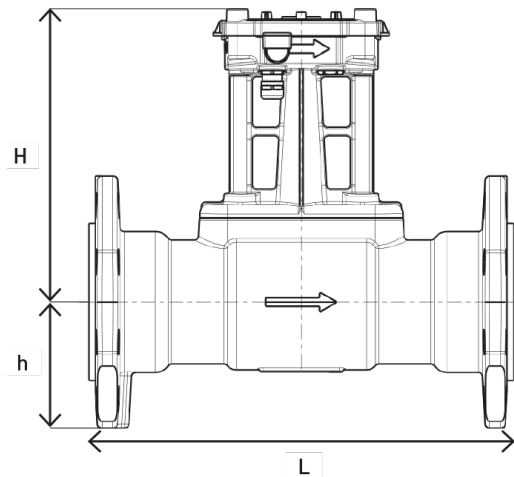

Materials

Body: Bronze

Installation

Pipeline:	horizontal	—
	vertical	
Meter head:	upwards	↑
	sideways	↔
	downwards	↓

Typical Head Loss Curve

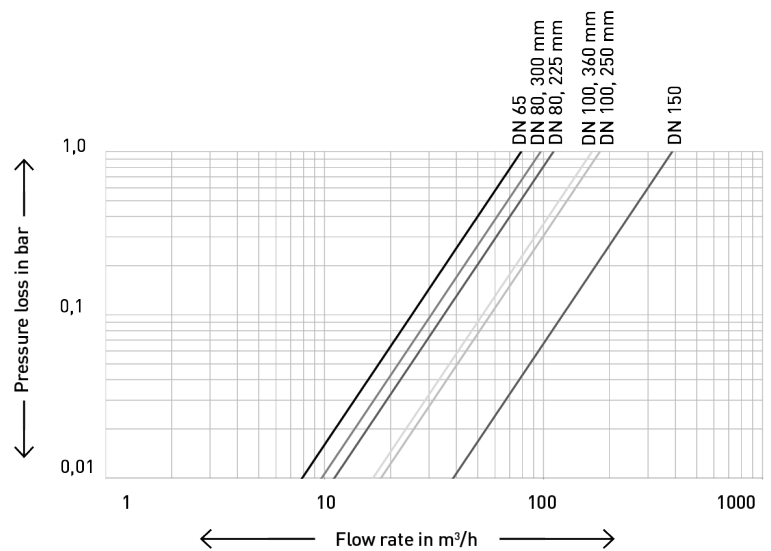

Installation - Recommendation

A straight inlet or outlet section is not required for AXONIC ultrasonic volume measuring meters. However, an inlet and outlet section of at least 5 x DN is recommendable if sufficient space is available.

Installation recommendations

The choice of installation site must ensure air cannot collect in the meter.

Technical data Pulse generator

Switching element		
Type		Passive Open collector
Switching voltage	U _{max}	30 V DC
Switching current	I _{max}	27 mA
Switching capacity	P _{max}	0.81 W
Pulse length		100 ms

Pulse value table

Pulse generator	DN 65...100 1 Pulse = ... Liters	DN 150 1 Pulse = ... Liters
Pulse	10	100

Installation – Recommendations

Pulse transmission interference

In case of interference during the pulse transmission between the pulse generator and the pulse receiver, (i.e. cable is in the same duct as power cable), we recommend shielded and twisted cables.