



Superstatic 789

Static Heat- and Cooling Meter



Your benefits

- Fluid oscillation principle:
High stability and repeatability for a long-term and accurate measurement, even with poor water quality
- No moving parts:
Not sensitive to dirt, air bubbles and liquids with changing viscosity
- High-Tech Composite (PPA, 50% glass fiber):
Robust and lightweight

Applications

- High-end device for building management
- All applications in district heating and cooling or building automation
- Optimally suited for glycol and other mixtures
- As a replacement for mechanical impeller heat meters

Properties

- Nominal diameter DN 15 or DN 20
- Nominal flow rates: qp 1.5 m³/h and 2.5 m³/h
- Max. operating pressure PN 16 bar
- Supply via 6+1 or 12+1-year battery or M-Bus with back-up battery
- Protection class of flow sensor IP68
- Threaded fittings
- No moving parts, therefore no wear
- Corrosion resistant materials
- Self-cleaning effect due to the fluid oscillating characteristic
- Temperature sensor Pt 1'000 (2-wires)
- LCD-resolution 8 digits
- Non-volatile memory EEPROM
- 18 month register (heat- and cooling energy and volume)
- Standard EN 1434 class 2
- **CE** Conformity according European Measuring Instruments Directive (MID)

Options

- Execution on-site reading
(supply via 6+1-year or 12+1-year battery)
- Execution with M-Bus Interface
(supply via M-Bus with 6+1-year back-up battery)
- Execution with wireless M-Bus (868 MHz, T-Mode)
(supply via 6+1-year or 12+1-year battery)

Technical Data

Volume measuring meter					
Nominal diameter	DN	mm	15	20	20
Operating pressure	PN	bar	16	16	16
Connection thread on meter	G...A	Inch	3/4	1	1
Connection thread on coupling	R...	Inch	1/2	3/4	3/4
Nominal flow rate	q _p	m ³ /h	1,5	1,5	1,5
Maximum flow rate	q _s	m ³ /h	3	3	5
Minimum flow rate	q _i	l/h	15	15	15
Low flow threshold value		l/h	10	10	17
Kvs value		m ³ /h	3,4	3,4	5,5
Pressure loss at q _p		bar	0,2	0,2	0,2
Max. Temperature		°C	110	110	110
Standard measuring range	q _i /q _p		1:100	1:100	1:100
Material			Comp	Comp	Comp

High-Tech Composite (PPA, 50% glass fiber)

Dimensions					
Length without couplings	L	mm	110	130	130
Height total	H	mm	118,5	118,5	113,4
Height from pipe centre line (with calculator)	C	mm	90	90	87,3
Height from pipe centre line (without calculator)	B	mm	54,5	54,5	52
Meter depth	D	mm	91,8	91,8	91,8
Calculator		mm	110,2 x 78	110,2 x 78	110,2 x 78
Meter weight		kg	0,72	0,74	0,75

Dimension Diagram

Superstatic 789, q_p 1,5 m³/h, L: 110 mm / 130 mm

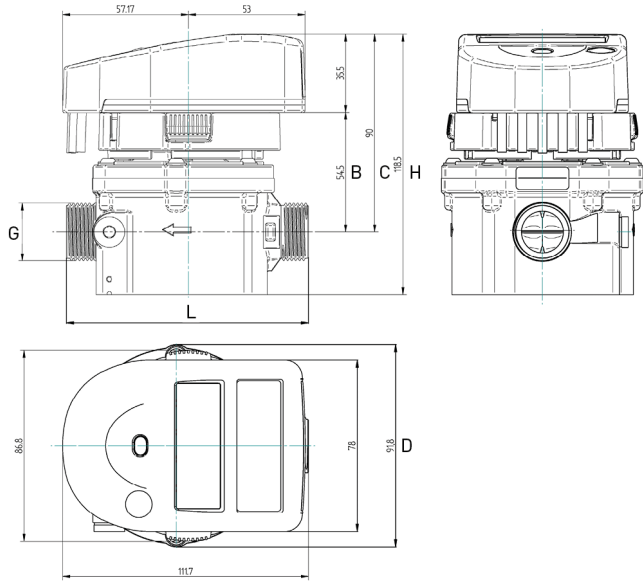

Superstatic 789, q_p 2,5 m³/h, L: 130 mm

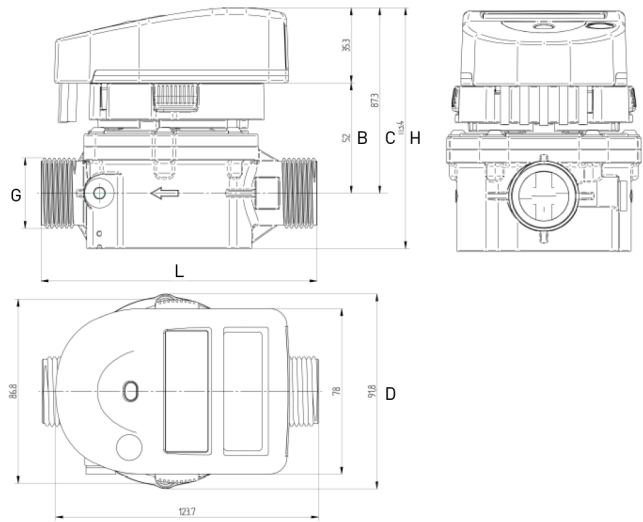

Specification for M-Bus interface

Protocol	Wired M-Bus according EN 13757
M-Bus standard load	2 standard loads (3 mA)
Standard baud rate	2400 Baud
Standard data set	Fabrication nr., energy (heat and cooling), volume, flow, power, temperatures (supply, return, difference), operating time, date and time, yearly key date values (energy and volume), software version, hardware version

Typical Head Loss Curve

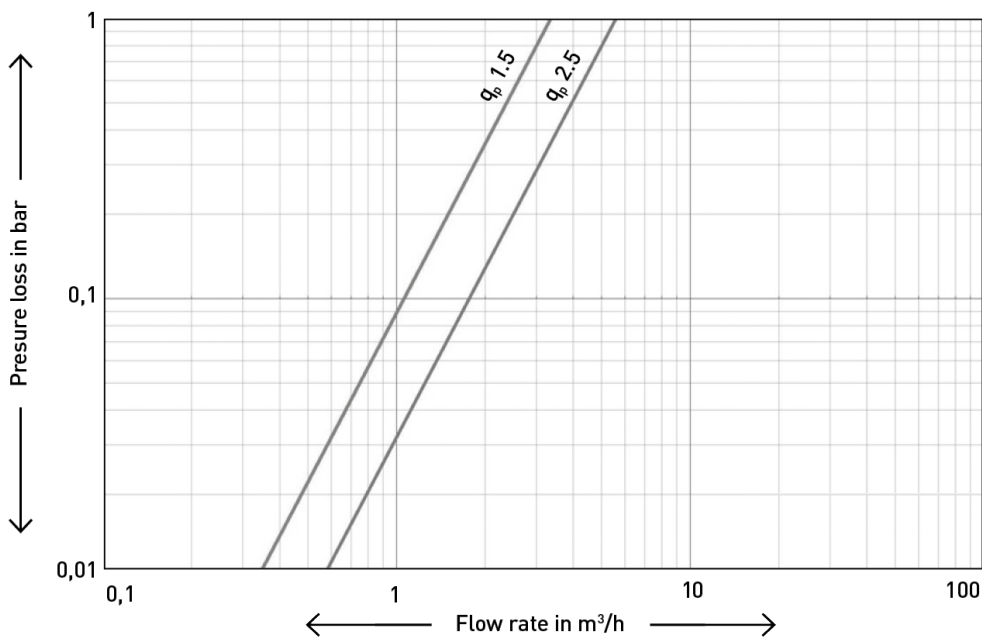

Technical Data: Calculator, temperature sensor and flow sensor

Calculator

Temperature sensor type	2-wire, Pt 1'000
Operating temperature	5 to 55 °C
Operating temperature with radio option	5 to 40 °C
Storage and transport temperature	-10 to 60 °C
Approved temperature range	0 to 110 °C
Differential range	3 to 75 K
Response limit	0.5 K
Temperatur resolution t (display)	0.1 °C
Temperatur resolution Δt (display)	0.01 K
Temp.-measurement cycle at nominal flow	10 s
Flow-measurement cycle	Permanent
Environment class	EN 1434 class C, 2004/22/EC class E1, M1
Battery protection class	III
Battery lifetime	6+1 or 12+1-year
Display units	kWh, m ³ , °C, K
LCD-Display resolution 8-digits	99'999'999 kWh 999'999,99 m ³
Protection class	IP65
Cable connection between flow sensor and calculator	0.6 m, fix

Temperature sensor

Sensor element	Pt 1'000
Connection diagram	2-wire
Diameter	Ø5.0 mm, M10x1
Cable length	1.5 m
Installation	Direct immersion

Flow sensor

Operating temperature	5 to 90 °C
Protection class	IP68
Metrological class approval acc.	EN 1434 class 2

The principle of fluid oscillator flow sensor

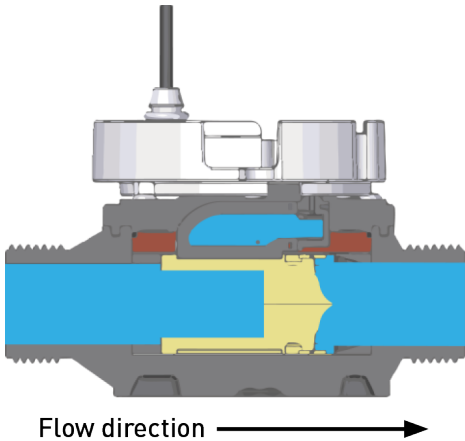

Picture 1:
Section through the flow sensor

The liquid passes through a special insert, the oscillator. Before passing the oscillator, the liquid is led to a nozzle and accelerated to a jet (oscillating jet). Opposite of the nozzle, the jet is redirected to the left or right into the channel. Due to the differential pressure generated in the channel, part of the liquid flows to the piezo-sensor above and part flows back to the pipe. The pressure of the liquid on the piezo-sensor generates an electrical pulse. Thus the liquid flows back to the pipe through a return loop and redirects the jet into the other channel. The liquid of this channel flows on the other side of the piezo-sensor and generates again an electrical pulse.

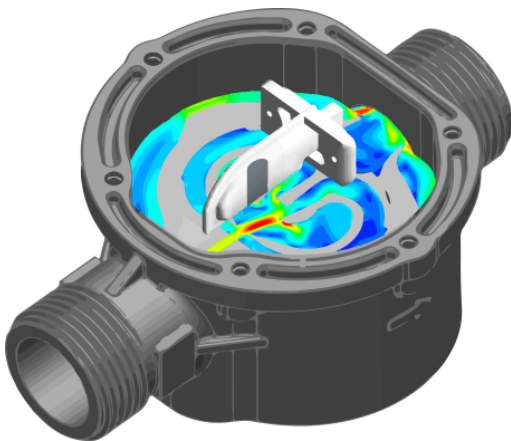

Picture 2:
Schematic of oscillator with oscillating jet (RED)

The animated top view shows the oscillating jet and its differences in velocity: The oscillation jet accelerated by the nozzle has the highest velocity and is visible in red. The jet that has slowed down is represented in blue. The electrical pulses generated by the piezo-sensor with differential pressure correspond to the movement, the frequency of the jet (proportional to the flow). The electrical pulses are recorded by the integrator connected through a cable to the flow sensor and converted into flow.

Installation

Pipeline	horizontal	—
	vertical	
Meter head:	+/- 45°	⊗

(for horizontal installation)

The Superstatic 789 should not be installed on the side where the continuous operating temperature of the liquid exceeds 90 °C or is below 5 °C.

See below length of straight section fitted up- or downstream of each flow meter (acc. EN1434):

U3 / D0 for: L=110 mm

U0 / D0 for: L=130 mm

Multi-function display

The LCD display of the Superstatic 789 has a large, clear design and high contrast. It can be rotated by 360°.

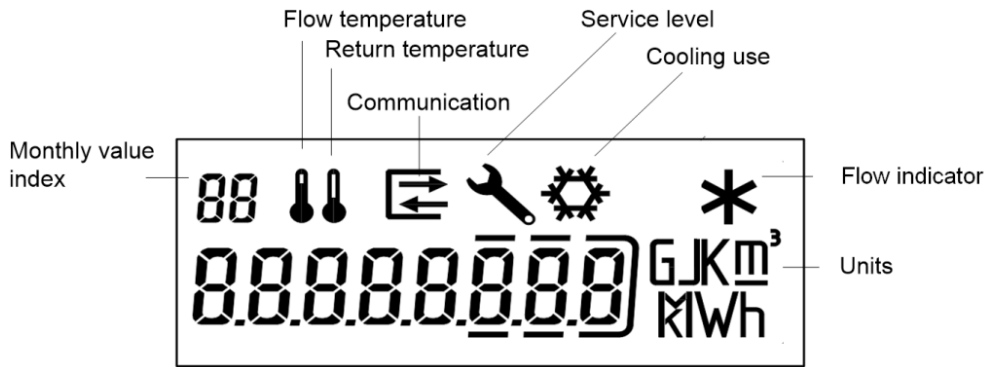

Display sequences

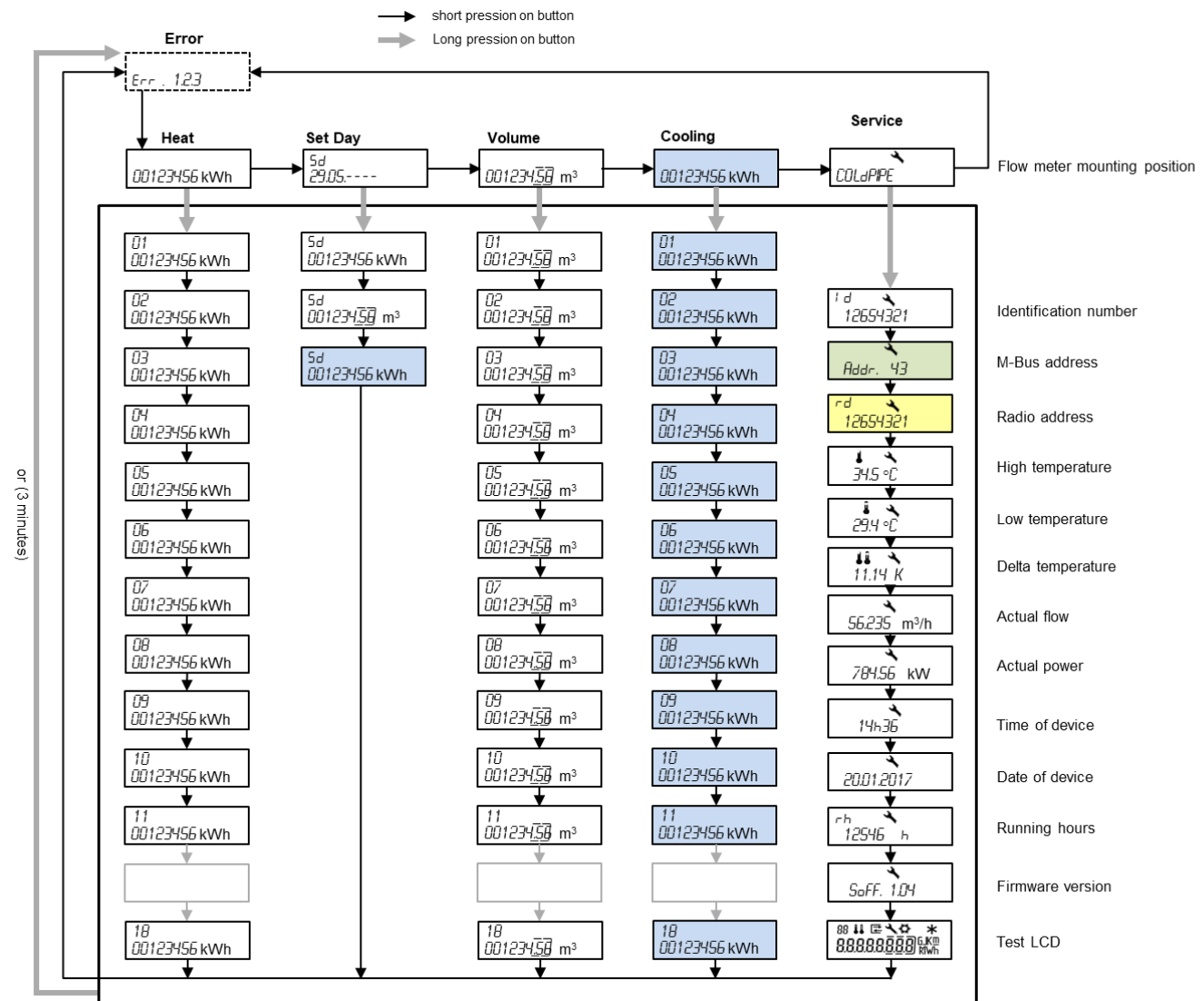

Error messages:

- Err 1 Flow higher than 1.2 x qs or faulty flow sensor.
- Err 2 Measured temperature out of range or faulty temperature sensor.