



Fluvius

For rivers and open channels



Your benefits

- Up to 10 acoustic measurement paths:
Exceptional accuracy, repeatability and linearity over the entire measurement range
- Highest-accuracy measurement:
Correct determination of flow using crosssectional geometry, water level and velocity in accordance to ISO 6416
- Automatic velocity profile approximation:
No need for time-consuming on-site calibration. Complex or varying flow behavior is taken into account
- Platform-independent web interface for configuration, operation and maintenance:
Easy and fast setup with multi-language graphical user interface. Parametrization with any mobile device, no software needed
- Installation flexibility for large rivers:
An optional responder for single or multiple planes can be integrated to avoid cables crossing the river

Applications

- Channels and rivers of width up to 20 m to 1000 m
- Suitable for applications under stationary nonuniform flow conditions (e.g. locks, gates and weirs)
- Flood protection and forecasting
- Permanent flow monitoring for hydrological applications:
 - Rivers, ship channels
 - Irrigation channels

Properties

- Compact aluminium housing, IP66
- Transducers for channel/river widths of 20 m to 1000 m
- Compliant with ISO 6416
- Time of flight technology with digital signal processing
- Measurement in multiple planes with single or crossed paths
- Flow profile calculation in multipath systems, no on-site calibration needed
- Bi-directional measurement over the entire flow range
- Uncertainty typically $\pm 2\%$ of measured flow value
- Measurement of low velocities down to 1,5 mm/s
- Integrated Wi-Fi access point
- Graphical user interface in multiple languages
- All units for display and data storage can be customized by the user
- Preconfigured cross sections or user-definable irregular shapes
- Analog inputs for external level sensors (2-wire loop-powered)
- Multiple analog and digital outputs, user programmable
- Communication: Ethernet, Modbus RTU/TCP, opt. 4G/3G/2G modem
- Power supply: 100 - 240 V AC or 9 - 36 V DC
- Internal data storage 16 GB

Options

- 1 to 10 acoustic measurement paths
- Additional responder for sensor connection on opposite river/channel side
- External 3G (HSPA) router

Product description

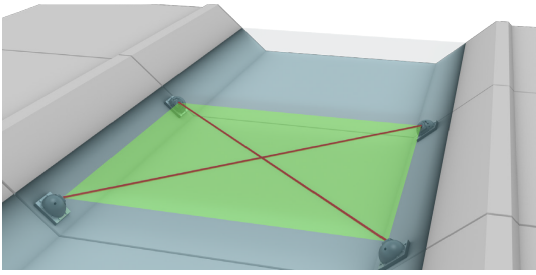

Crossed-path Fluvius system in channel

Fluvius is a time of flight system designed for permanent flow monitoring in natural or manmade waterways. Fluvius is a metering solution with up to 10 acoustic paths. It operates bidirectionally without causing obstruction or head loss. Accurate flow measurement is crucial for flood protection and for controlling the minimum ecological flow. The range of application for Fluvius runs from small waterways to huge river systems with high suspended solids concentration.

Measuring principle

Fluvius is an area velocity ultrasonic flowmeter which uses the time of flight method. An ultrasonic pulse is sent with and against flow direction. The difference in signal travelling time (time of flight) is then evaluated. Combined with water level measurement and the cross-sectional area, Fluvius accurately determines flow over its entire measuring range. Fluvius can measure in up to 10 acoustic paths, e.g. in five planes with two crossed paths each.

Multi-path systems have several advantages:

1. Cross flows in channels and rivers may form due to conditions such as bends in the river course. Although cross flows do not influence the total flow volume, they can affect the measurement accuracy. With a crosswise arrangement of four transducers, secondary flow effects can be eliminated.
2. When water levels in channels or rivers are changing significantly, multiple paths ensure that the flow profile is measured consistently. With rising water level, more acoustic paths are activated. This system guarantees measurement accuracy at all times.
3. A system with acoustic paths layered on top of each other in parallel planes removes the need for a timeconsuming hydrometric calibration. For these reasons, the Fluvius system is suitable for applications with large water level fluctuations, reverse flow or a vertical velocity distribution outside the theoretical normal.

Component description

The Fluvius system is composed of a wall-mounted transmitter and several transducer options depending on acoustic path lengths and sediment load.

Transmitter



Standard transmitter and multi-path extension housing

The Fluvius transmitter incorporates all the required algorithms and software to ensure measurement accuracy and repeatability. The transmitter controls the measurements, calculates the flow rate and provides freely programmable current outputs, status alarms, frequency outputs and totalizer readings. The IP65 (NEMA 4X) powder-coated sheet steel housing features a 4 x 20 alphanumeric LCD. The Fluvius standard transmitter accommodates 2 acoustic paths. For systems with up to 10 measurement paths, an extension housing is available.

Velocity sensor

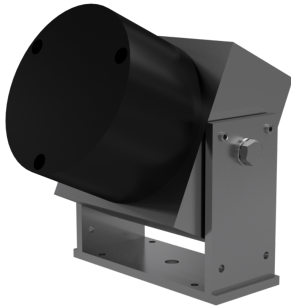

Transducer TD-28/18, 28 kHz

The Fluvius sensors are mounted on the side of river, channel or conduit walls. The mounting from the side prevents aggregation of sediments on top of the sensor and enables easy installation and cleaning. Standardized sensor mounting devices are available for any kind of channel geometry like rectangular, trapezoid or natural riverbanks. The flow-optimized design protects the transducers against moving objects suspended in the flow stream. This method has proved its worth for applications in channels or rivers with high waste contents. The enclosure design also provides room for connections and protective conduits.

Pressure level sensor



Pressure level sensor

The Fluvius system may be combined with an external pressure level sensor via the analog input of the transmitter. A 16-bit A/D converter for analog signal outputs (4-20 mA) is integrated in the microprocessor of the sensor. This converter measures the sensor signal up to 500 times per second. The micro-processor electronics mathematically compensate temperature dependencies and non-linearities, resulting in high-accuracy measurement of typically 0,04 % FS and a total error band of 0,15 % FS over the entire pressure and temperature range.

Technical Data

Transmitter

The Fluvius system may be combined with an external pressure level sensor via the analog input of the transmitter. A 16-bit A/D converter for analog signal outputs (4-20 mA) is integrated in the microprocessor of the sensor. This converter measures the sensor signal up to 500 times per second. The micro-processor electronics mathematically compensate temperature dependencies and non-linearities, resulting in high-accuracy measurement of typically 0,04 % FS and a total error band of 0,15 % FS over the entire pressure and temperature range.

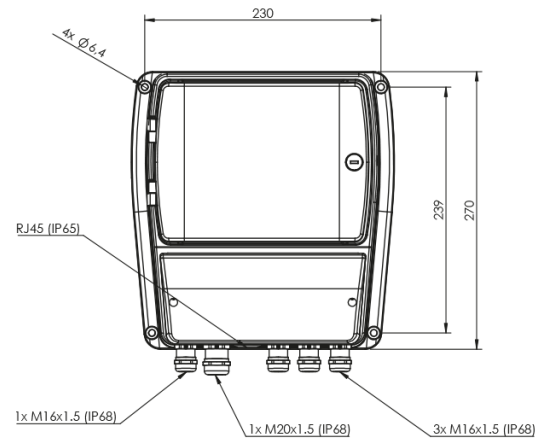

	Transmitter
Display	4 lines, 20 characters
Keyboard	4 keys
Datalogger	16 GB Micro SD card
Communication	RS485 or RS232, Modbus RTU/TCP, WLAN, 4G (LTE) / 3G (HSPA+) / 2G, Ethernet 10/100 Mbps
Inputs	max. 4 x 4 - 20 mA, 2 x digital
Outputs	max. 4 x 4 - 20 mA, 4 x relay, 2 x digital
Power supply	9 - 36 V DC or 100 - 240 V AC (50/60 Hz)
Enclosure	Aluminium
Ingress protection	IP66 (NEMA 4)
Ambient temperature	-15 to + 60 °C
Storage temperature	-20 to + 70 °C
Dimensions	270 x 256 x 139 mm (L x W x H)

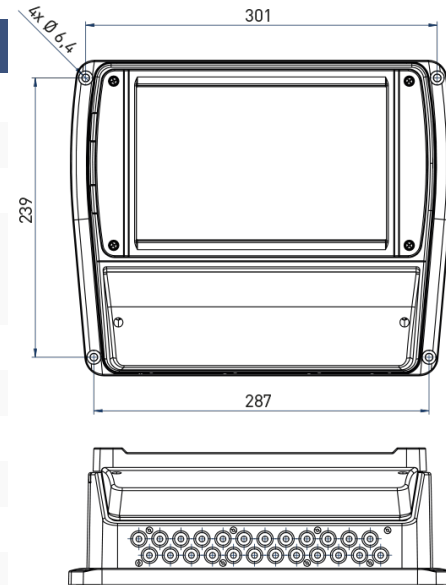

	Fluvius multi-path extension
Acoustic paths	3 to 10
Power supply	9 - 36 V DC
Enclosure	Aluminium
Ingress protection	IP66 (NEMA 4)
Ambient temperature	-15 to + 60 °C
Storage temperature	-20 to + 70 °C
Dimensions	301 x 270 x 118 mm (L x W x H)

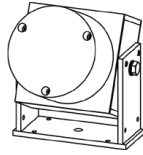
**TD-28/18****Sensor**

Frequency	28 kHz
Beam width	18° [-3 dB]
Typical channel width	> 400 m
Mounting	box-shaped assembly; transducer can be rotated up to 90° in any direction
Dimensions	Ø 183 mm, height 142 mm
Sensor weight	8 kg