

Technical description

MULTICAL® 303



List of words and symbols

Word/symbol	Meaning	Unit	Expired designations
q_i	Minimum approved flow	[l/h]	$Q_i, q_{vmin}, Q_{min}, q_{min}$
q_p	Permanent/approved nominal flow	[m ³ /h]	$Q_s, q_{vmax}, Q_n, q_n, q_{max}$
q_s	Maximum approved flow ¹	[m ³ /h]	Q_{max}
θ	Temperature range of calculator	[°C]	
θ_q	Temperature range of flow sensor (medium)	[°C]	
θ_{hc}	Limit value for shift between heat and cooling ²	[°C]	
$\Delta\theta$	Temperature difference of inlet and outlet	[K]	
t_{BAT}	Battery temperature	[°C]	
DN	Nominal diameter	[mm]	
PN	Nominal pressure	[bar]	
E_c	Max permissible error of calculator	[%]	
E_f	Max permissible error of flow sensor	[%]	
E_t	Max permissible error of temperature sensors	[%]	
MPE	Maximum permissible error	[%]	
PQ	Power and flow in connection with tariff		
GF	Glass fibre reinforcement		
KMP	Kamstrup Meter Protocol		

¹ Less than an hour/day and less than 200 hours/year

² Only available in meter type 6

Contents

1	General description	7
1.1	Mechanical construction.....	8
1.2	Electronic structure.....	9
2	Technical data	10
2.1	Approved meter data.....	10
2.2	Electrical data.....	11
2.3	Mechanical data.....	12
2.4	Materials	12
2.5	Accuracy.....	13
3	Type overview	14
3.1	Type number.....	15
3.1.1	Accessories	16
3.2	Configuration number.....	18
3.2.1	Flow sensor position >A<.....	19
3.2.2	Measuring unit >B<.....	19
3.2.3	Flow sensor coding >CCC<.....	19
3.2.4	Display code >DDD<.....	21
3.2.5	Integration mode >L<	22
3.2.6	Data logger profile >RR<.....	23
3.2.7	Encryption level >T<.....	27
3.2.8	Customer label >VVV<	27
3.3	Data.....	28
3.4	Serial number and extended availability	30
3.5	Target date.....	31
4	Installation.....	32
4.1	Installation requirements.....	32
4.2	Inlet conditions	33
4.3	Orientation of Kamstrup's flow sensors	34
4.3.2	Heat installation recommendations.....	35
4.3.3	Recommendations for cooling and combined heat/cooling installations.....	35
4.3.4	Recommendations for directly mounted temperature sensors.....	36
4.4	Calculator position	38
4.5	Operating pressure for MULTICAL® 303	39
4.6	Mounting in inlet or outlet.....	40

4.7	EMC conditions.....	40
4.8	Climatic conditions	41
4.9	Sealing	41
4.10	Pressure loss.....	42
5	Dimensioned sketches.....	43
6	Display	45
6.1	“USER loop”	49
6.2	“TECH loop”	49
6.3	“SETUP loop”	52
6.3.1	Changing parameters in “SETUP loop”	53
6.4	“TEST loop”	61
7	Calculator functions.....	62
7.1	Application types and energy calculations	62
7.1.1	Heat/cooling energy registers E1 and E3	62
7.1.2	Energy registers E8 and E9.....	63
7.1.3	Energy calculations.....	65
7.2	Offset adjustment of temperature sensor measurement	67
7.3	Bifunctional heat/cooling metering.....	68
7.4	Min./max calculations of power (P) and flow (Q).....	69
7.5	Temperature measurement	71
7.6	Information code types	72
7.6.1	Information code types on the display.....	72
7.6.2	Examples of information codes	73
7.6.3	Information codes in display and in serial communication	74
7.6.4	Information codes in transport state	74
7.7	Transport state	75
7.8	Info and config. logger.....	77
7.8.1	Info logger	77
7.8.2	Config. logger	77
7.9	Summer/standard time adjustment	78
8	Flow sensor	79
8.1	Measuring principles	79
8.2	Signal path and flow calculation	79
8.3	Flow limits.....	81

9	Temperature sensors	82
9.1	Temperature sensor types	83
9.2	DS 27,5 mm direct short temperature sensor	83
9.3	Ø5,0 mm / Ø5,2 mm temperature sensors	84
9.3.1	Installation of Ø5,0 mm / Ø5,2 mm temperature sensors as direct temperature sensors	85
9.3.2	Installation of Ø5,0 mm / Ø5,2 mm temperature sensors as pocket sensors	86
9.4	Identification of inlet and outlet temperature sensors	87
10	Voltage supply	88
10.1	Battery lifetimes	88
10.2	Replacement of batteries	88
11	Communication	89
11.1	Communication types	89
11.1.1	M-Bus, type: 20	89
11.1.2	Wireless M-Bus, 868 MHz, type: 30	89
11.2	Communication configuration >XXX-YY-ZZZ<	90
11.2.1	Hardware configuration >XXX<	90
11.2.2	System configuration >YY<	90
11.2.3	Datagram configuration >ZZZ<	90
12	Data communication	92
12.1	MULTICAL® 303 data protocol	92
12.2	Optical interface	92
12.2.1	Power savings in connection with the optical read-out head	92
12.3	Data protocol	92
13	Test and calibration	93
13.1	Meter cycle	93
13.2	Test	94
13.2.1	Test of flow sensor	94
13.2.2	Test of calculator	94
13.3	High-resolution volume and energy	94
13.3.1	Reading of high-resolution registers	94
13.4	Temperature calibration	95
13.5	Pulse interface	95
13.5.1	Verification pulses	96
13.5.2	Use of high-resolution pulses	96
13.6	True energy calculation	97

MULTICAL® 303

14	Approvals.....	98
14.1	Type approvals.....	98
14.2	Measuring Instruments Directive	98
15	Troubleshooting.....	99
16	Disposal	100
17	Documents.....	101

1 General description

MULTICAL® 303 is a static heat meter, cooling meter or bifunctional heat/cooling meter based on the ultrasonic principle. The meter is intended for energy measurement in almost all types of thermal installations where water is used as the energy-conveying medium.

According to EN 1434, MULTICAL® 303 can be designated as a “hybrid instrument”, also called a compact meter. In practice, this means that flow sensor and calculator unit may not be separated.

If flow sensor and calculator unit have been separated, and the sealings have thus been broken, the meter will no longer be valid for billing purposes and at the same time, the factory guarantee no longer applies.

MULTICAL® 303 is constructed with ultrasonic measurement, ASIC and microprocessor technique. A single-board construction comprises all calculating and flow measuring circuits, which provides a compact and rational design and, in addition, exceptionally high measuring accuracy and reliability are obtained.

The volume measurement is carried out through bidirectional ultrasound technique according to the transit time difference principle, which is a long-term stable and accurate measuring principle. The ultrasonic signal is sent through two ultrasound transducers both along and against the flow direction. The ultrasound signal travelling in the flow direction will reach the opposite transducer first, and the time difference between the two signals can then be converted into flow velocity and thus also into volume.

The temperature measurements in inlet and outlet are performed with accurately paired Pt500 sensors according to EN 60751.

MULTICAL® 303 comes with various Pt500 sensor sets, e.g. direct short sensors according to EN 1434-2, Ø5,0 mm and Ø5,2 mm pocket sensors, which can be used as both direct sensors using Kamstrup's M10 composite union and as pocket sensors in common Ø5,0 and Ø5,2 sensor pockets¹.

Sensor sets may only be replaced at calibration laboratories, not by the meter installer.

The accumulated heat energy and/or cooling energy can be shown in kWh, MWh or GJ, all with seven or eight significant digits plus measuring unit. The display is specially designed with a view to obtaining long lifetime and sharp contrast in a wide temperature range.

Other possible display views are, among other things, accumulated water consumption, operating hour counter, error hour counter, current temperature measurements, current flow and power readings. Furthermore, MULTICAL® 303 can be configured to show monthly and yearly logs, target date, max/min. flow, max/min. power, information code and current date.

MULTICAL® 303 is mains-supplied by one or two internal A-cell lithium batteries with a lifetime of up to 16 years.

MULTICAL® 303 comes with either M-Bus or wM-Bus. See paragraph 11.1 for details.

This technical description has been written with a view to enabling operations managers, meter installers, consulting engineers and distributors to utilize all functions comprised in MULTICAL® 303. Furthermore, the description is targeted at laboratories performing tests and verification.

This technical description is updated regularly. Find the latest edition at

<https://www.kamstrup.com/en-en/heat-solutions/meters-devices/meters/multical-303/documents>

¹ Some EU countries only allow the installation of direct sensors.

1.1 Mechanical construction

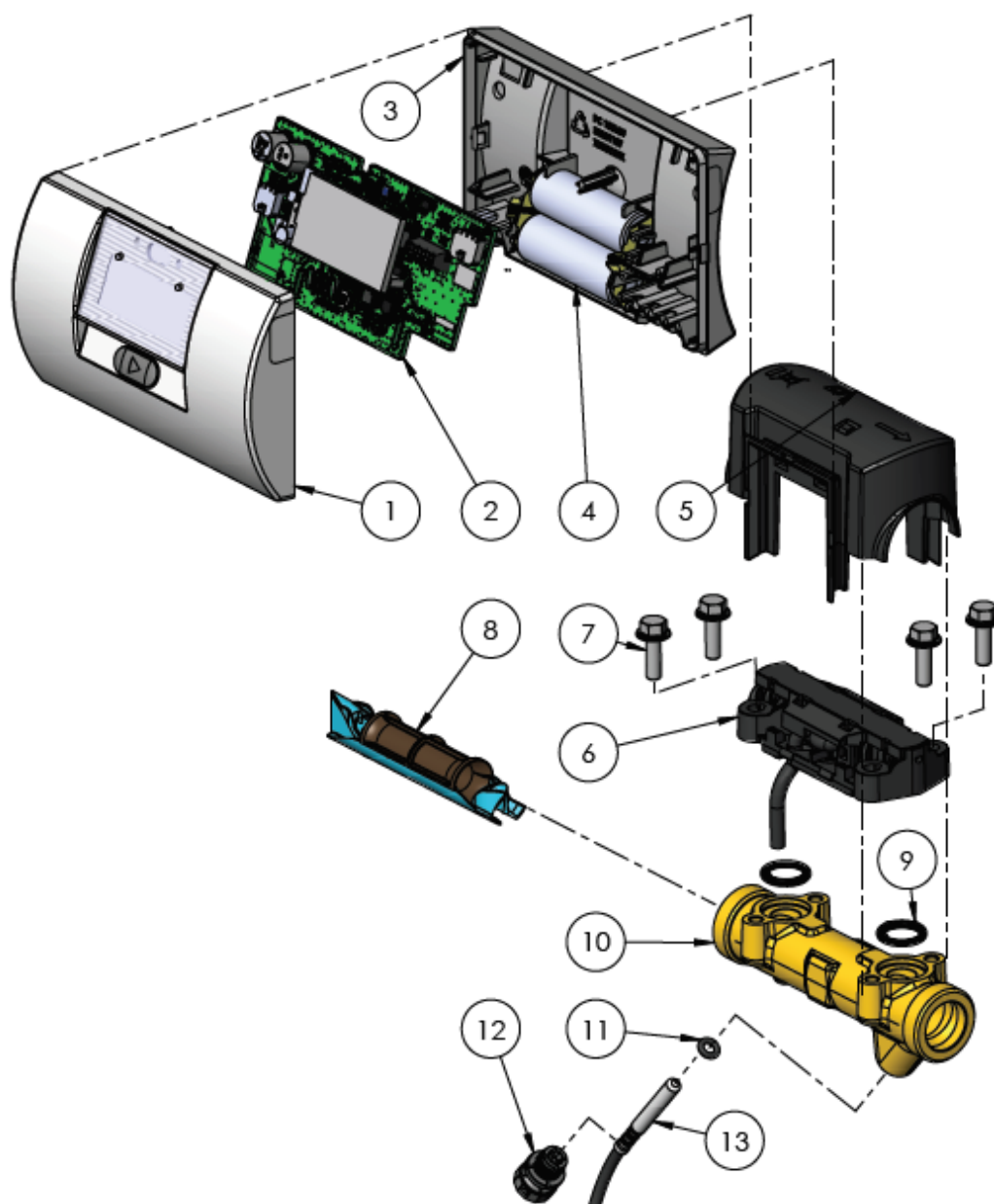

Figure 1

1	Top cover with front key and laser engraving
2	PCB with microcontroller, flow-ASIC, display, etc.
3	Base cover (may only be opened by an authorised laboratory)
4	One or two A-cell batteries
5	Flow sensor cover (may only be opened by an authorised laboratory)
6	Piezo cell console

7	Screws for piezo cell console
8	Ultrasound measuring tube
9	O-rings, piezo cells
10	Brass casing
11	O-ring, temperature sensor
12	Union, temperature sensor
13	Temperature sensor (ø5,0 – ø5,2 – DS 27,5)

1.2 Electronic structure

The electronic construction of MULTICAL® 303 is shown in the block diagram below. The communication interface of MULTICAL® 303 is integrated and can be selected as either M-Bus or Wireless M-Bus. MULTICAL® 303 is available in two battery-supplied variants, one variant with one A-cell battery and another variant with two A-cell batteries.

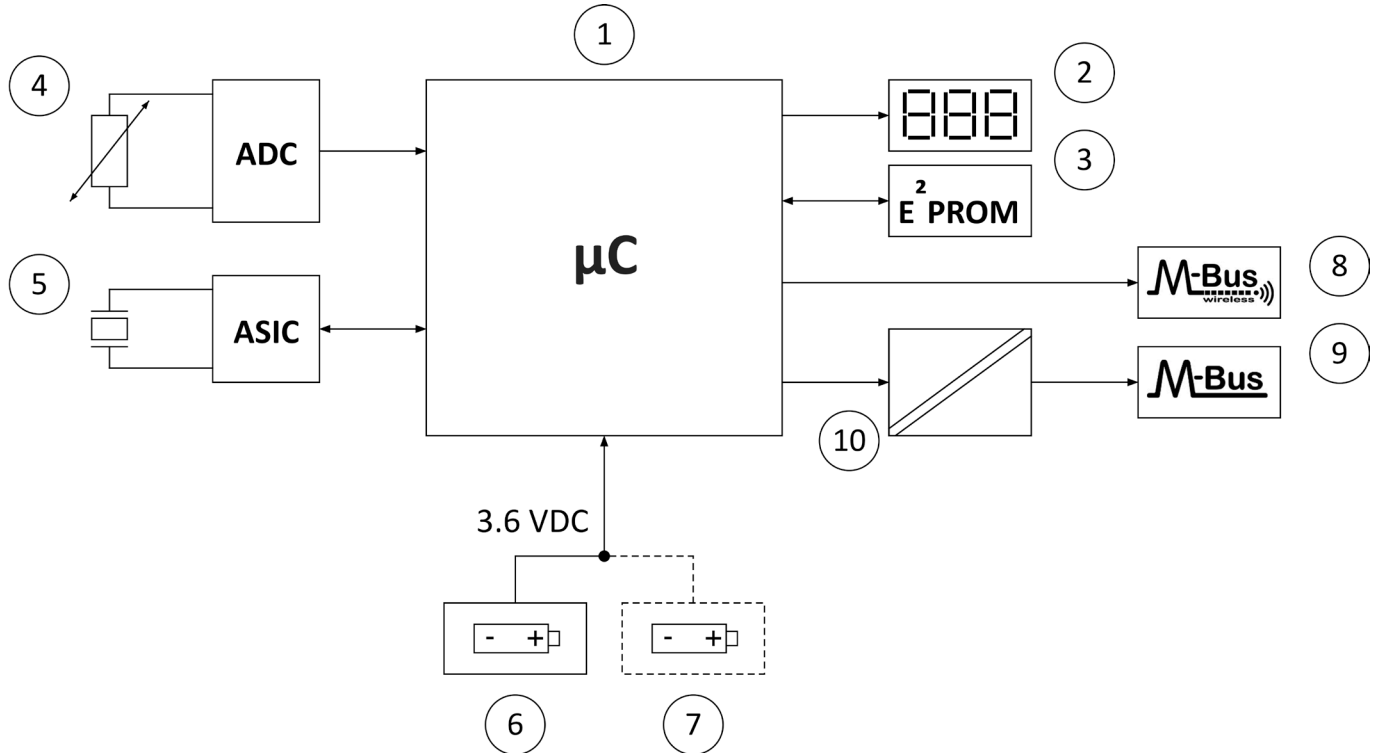

1	Microcontroller
2	Display, eight-digit 7-segment + icons
3	Non-volatile memory, EEPROM
4	Temperature sensors, Pt500
5	Flow sensor, piezo elements

6	Lithium battery 1 x A-cell
7	Extra lithium battery 1 x A-cell (option)
8	Wireless M-Bus
9	... or M-Bus
10	Galvanic separation

Note The arrows in the figure indicate the signal direction.

2 Technical data

2.1 Approved meter data

Approvals **DK-0200-MI004-045, heat meter**
 according to MID 2014/32 EU,
 EN 1434:2007/AC:2007
 EN 1434:2015 + A1:2018
 EN 1434:2022
 WELMEC 7.2:2021 and
 OIML R 75:2002

TS 27.02.015 cooling meter and heat/cooling meter
 according to DK-BEK 1178,
 EN 1434:2007/AC:2007,
 EN 1434:2015 + A1:2018 and
 EN 1434:2022

EU directives Measuring Instrument Directive, Low Voltage Directive,
 Electromagnetic Compatibility Directive, Pressurized Equipment Directive,
 Radio Equipment Directive, RoHS Directive

Heat meter approval DK-0200-MI004-045
 Temperature range θ : 2 °C...180 °C
 Differential range $\Delta\theta$: 3 K...178 K
 The stated minimum temperatures are related to the type approval only.

Cooling and heat/cooling meter TS 27.02.015
 Temperature range θ : 2 °C...180 °C
 Differential range $\Delta\theta$: 3 K...178 K
 Differential range, cut-off 0,00...2,50 K
 The meter has a configurable cut-off for low temperature and thus measures down to 0,01 °C and 0,01 K.

Media temperature θ_q : 2 °C...130 °C

Accuracy
 - Calculator $E_c = \pm (0,5 + \Delta\theta_{min}/\Delta\theta) \%$
 - Flow sensor $E_f = \pm (2 + 0,02 q_p/q)$, but not above $\pm 5 \%$

Temperature sensor connection Pt500 – EN 60751, 2-wire connection

EN 1434 designation Environmental class A

MID designation Mechanical environment: Class M1 and M2
 Electromagnetic environment: Class E1
 Condensing environment, closed location (indoors), 5...55 °C

<i>Type number</i>	Nom. flow q_p [m³/h]	Max flow q_s [m³/h]	Min. flow q_i [l/h]	Dynamic range [$q_p:q_i$]	Min. flow cut-off [l/h]	Saturation flow [m³/h]	Pressure loss $\Delta p @ q_p$ [bar]	Connection on meter	Length [mm]
303-x-10	0,6	1,2	6	100:1	3	1,5	0,03	G¾B	110
303-x-40	1,5	3,0	15	100:1	3	4,6	0,09	G¾B	110
303-x-70	1,5	3,0	15	100:1	3	4,6	0,09	G1B	130
303-x-A0	2,5	5,0	25	100:1	5	7,6	0,09	G1B	130

Table 1

2.2 Electrical data

Calculator data

Typical accuracy	Calculator: $E_c \pm (0,15 + 2/\Delta\Theta) \%$	Sensor set: $E_t \pm (0,4 + 4/\Delta\Theta) \%$
Display	LCD – 7 or 8 digits with a digit height of 6,8 mm	
Resolutions	9999,999 – 99999,99 – 999999,9 – 9999999 99999,999 – 999999,99 – 9999999,9 – 99999999	
Energy units	MWh – kWh – GJ	
Data logger (EEPROM), programmable	Logging intervals: From 1 minute to 1 year Logger contents: All count registers can be selected Standard logger profile: 20 years, 36 months, 460 days, 72 hours	
Info logger (EEPROM)	50 info codes	
Clock/calendar	Clock, calendar, leap year compensation, target date	
Clock accuracy	Without external adjustments	Less than 15 minutes/year
	With external adjustment every 48 hours	Less than 7 s from legal time
Summer time/standard time (DST)	Programmable under country code This function can be disabled so that “technical normal time” is used	
Data communication	KMP protocol with CRC16 is used for optical communication as well as M-Bus and wM-Bus	
Power in temperature sensors	< 10 μ W RMS	
Supply voltage	3,6 VDC \pm 0.1 VDC	
Battery	3,65 VDC, 1 x A-cell lithium 3,65 VDC, 2 x A-cell lithium	
Replacement interval		
- Mounted on wall	8 years @ $t_{BAT} < 30 \text{ }^\circ\text{C}$	16 years @ $t_{BAT} < 30 \text{ }^\circ\text{C}$
- Mounted on flow sensor	6 years @ $t_{BAT} < 40 \text{ }^\circ\text{C}$	12 years @ $t_{BAT} < 40 \text{ }^\circ\text{C}$
	See paragraph 10 for further details.	
EMC data	Fulfils EN 1434 class A (MID class E1)	

MULTICAL® 303

Temperature measurement	t1 Inlet temperature	t2 Outlet temperature	ΔΘ (t1-t2) Heat measurement	ΔΘ (t2-t1) Cooling measurement
Measurement range	0,00...185,00 °C			

Offset adjustment ± 0,99 K joint zero point adjustment for the inlet and outlet temperatures
See paragraph 7.2.

Cable lengths 1,5 and 3 m

2.3 Mechanical data

Environmental class Fulfils MID class M1 and M2
Ambient temperature 5...55 °C, closed location (indoor installation)
Protection class Calculator: IP65 Flow sensor: IP68 According to EN/IEC 60529

Media temperatures

2...130 °C At media temperatures below the ambient temperature or above 90 °C in the flow sensor, wall-mounting of the calculator is recommend.

Medium in flow sensor Water (district heating water as described in AGFW FW510)

Storage temperature -25...60 °C (drained flow sensor)

Pressure stage PN16/PN25, PS25

Weight From 0,7 to 0,8 kg depending on the flow sensor size

Flow sensor cable 1,5 m (the cable is non-detachable)

2.4 Materials

Wetted parts	Casing, thread	Hot forged, dezincification-resistant brass (CW 602N)
	Transducer	Stainless steel, w.nr. 1.4404
	O-rings	EPDM
	Measuring tube	Thermoplastic, PES 30 % GF
	Reflectors	Thermoplastic, PES 30 % GF and stainless steel, w.nr. 1.4306
Flow sensor casing		Thermoplastic, PC 20 % GF
Calculator casing	Top	Thermoplastic, PC 10 % GF with TPE (thermoplastic elastomers)
	Base	Thermoplastic, PC 10 % GF
Cables	Flow sensor cable	Silicone cable with inner Teflon insulation
	Temperature sensor cable	Silicone cable with inner Teflon insulation
	M-Bus cable	PVC cable

2.5 Accuracy

Subunits of the meter	MPE according to EN 1434-1	MULTICAL® 303, typical accuracy
Flow sensor	$E_f = \pm (2 + 0,02 q_p/q)$, but not above $\pm 5\%$	$E_f = \pm (1 + 0,01 q_p/q)\%$
Calculator	$E_c = \pm (0,5 + \Delta\Theta_{\min}/\Delta\Theta)\%$	$E_c = \pm (0,15 + 2/\Delta\Theta)\%$
Sensor set	$E_t = \pm (0,5 + 3 \Delta\Theta_{\min}/\Delta\Theta)\%$	$E_t = \pm (0,4 + 4/\Delta\Theta)\%$

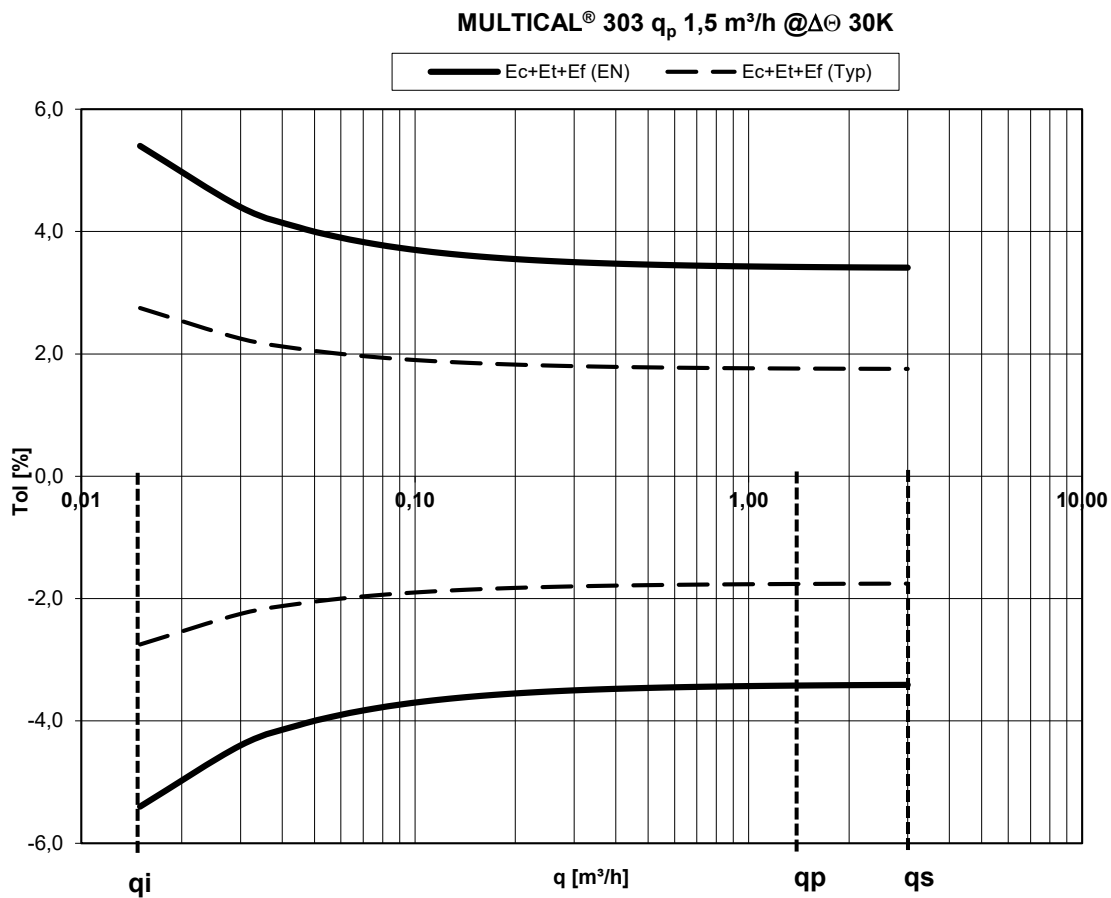
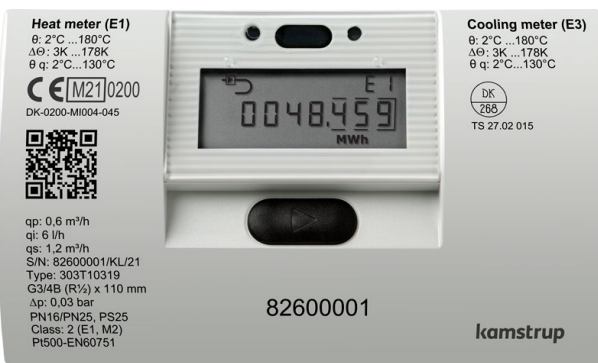

Diagram 1: Total typical accuracy of MULTICAL® 303 compared to EN 1434-1

3 Type overview

MULTICAL® 303 can be ordered in countless combinations as required by the customer. First select the required hardware from the type number overview and then, select the required software configuration via the configuration number (config. number). Furthermore, a number of data is configured under the country code, which includes, for example, the definition of GMT, the primary M-Bus address as well as the yearly and monthly target date. Through these selections and configurations, MULTICAL® 303 can be adjusted for its current task.

The meter has been configured from the factory and is ready for use. It can, however, be changed/reconfigured after installation. Reconfiguration can be carried out from the meter’s “SETUP loop” by means of the front key or MeterToolX/HCW. For further information on MeterTool HCW, see the technical description 5512-2097. For further information on setup using the front key via “SETUP loop”, see paragraph 6.3.



Type number:

>303-xxxxxx-xxxxx<

The first 9 digits of the type number (303-xxxxxx-xxxxx) are written on the meter’s front and cannot be changed after production. The last 5 digits of the type number (603-xxxxxx-xxxxx) are not written on the meter, but can be read from the display.

Config. number:

>A-B-CCC-DDD-L-RR-T-VVVV<

The config. number is not written on the meter, but can be displayed distributed on two readings in “TECH loop”.

Config 1: >A-B-CCC-DDD<

Flow sensor position-Measuring unit-Resolution-Display code

Config 2: >L-RR-T-VVVV<

Integration mode-Data logger profile-Encryption level-Customer label

Config. communication: >XXX-YY-ZZZ<

Meter and communication type-System configuration-Datagram contents

Serial number:

>xxxxxxxx/WW/yy<

Consisting of:

8-digit serial number (xxxxxxxx)

2-digit device code for extended availability (WW), see paragraph 3.4

2 digits for production year (yy)

The unique serial number is written on the meter and cannot be changed after factory configuration.

Data:

During production, MULTICAL® 303 is configured with a number of measuring values. See paragraph 3.3 for further details about these measuring values.

3.1 Type number

				Static data 303-XXXXXX - Written on the meter's front				Dynamic data XXXXX Shown in display		
Type 303 -				□	□□	□	□□	□□	□	□□
Sensor connection										
Pt500 heat meter				W						
Pt500 heat/cooling meter				T						
Pt500 cooling meter				C						
Flow sensor¹										
q _p [m ³ /h]	Connection	Length [mm]	Dynamic range							
0,6	G¾B (R½)	110	100:1	10						
1,5	G¾B (R½)	110	100:1	40						
1,5	G1B (R¾)	130	100:1	70						
2,5	G1B (R¾)	130	100:1	A0						
Meter type										
Heat meter (MID module B+D)				2						
Heat/cooling meter (MID module B+D & TS27.02+DK268) ²				θ _{hc} = off			3			
Heat meter, National approvals				4						
Cooling meter (TS27.02+DK268)				5						
Heat/cooling meter (MID module B+D & TS27.02+DK268) ²				θ _{hc} = on			6			
Country code										
See paragraph 3.3.				XX						
Sensor set (Pt500)										
	Length [mm]	Diameter Ø [mm]	Cable length [m]							
Direct short sensor set	27,5	-	1,5	51						
Direct short sensor set	27,5	-	3,0	52						
Ø5,0 with composite union	-	5,0	1,5	61						
Ø5,0 with composite union	-	5,0	3,0	62						
Ø5,2 with composite union	-	5,2	1,5	71						
Ø5,2 with composite union	-	5,2	3,0	72						
Supply³										
Battery, 1 x A-cell		Lifetime of up to 8 years				1				
Battery, 2 x A-cell		Lifetime of up to 16 years				9				
Communication (Built-in)										
M-Bus, configurable				20						
Wireless M-Bus, configurable, 868.95 MHz EU				30						

¹ The flow sensors are type-approved for the dynamic ranges q_p:q_i = 250:1 and 100:1, but are as a rule always delivered as 100:1. Please contact Kamstrup A/S for information on which of the above-mentioned MULTICAL® 303 variants are available on the individual markets.

² In some countries bi-functional meters type 3 and 6 are only allowed to be assigned with the MID marking, due to national law.

³ See conditions for stated battery lifetime in paragraph 10.1. For calculations of specific configurations, please contact Kamstrup A/S.

MULTICAL® 303

3.1.1 Accessories

Various accessories

Article number	Description
3026-517	Sealing cap for temperature sensor DS27,5, blue
3026-518	Sealing cap for temperature sensor DS27,5, red
3026-1034	Sealing cap for $\varnothing 5,0$ mm / $\varnothing 5,2$ mm temperature sensor with composite union, black
2105-002	Sealing cap for coupling G $\frac{3}{4}$ B (R $\frac{1}{2}$), blue
3026-1148	Sealing cap for coupling G $\frac{3}{4}$ B (R $\frac{1}{2}$), self-locking, blue
3026-655.A	Wall bracket including mounting kit
3026-902	Bracket for mounting MULTICAL® 303 on MULTICAL® 402 wall bracket
3026-909	Bracket for optical read-out head
3130-262	Blind plug including O-ring
6699-042	Metal plate for optical read-out head, 20 pcs.
6696-005	Optical read-out head with Bluetooth
6699-099	Optical read-out head with USB plug

Calibration equipment

Article number	Description
6699-303	Calibration unit for MULTICAL® 303, Pt500, Heat/Cooling

Software

Article number	Description
6699-724	METER TOOL HCW
6699-725	LogView HCW

Couplings

Article number	Description
6561-323	Coupling incl. gasket, DN15, G $\frac{3}{4}$ B - R $\frac{1}{2}$, 2 pcs.
6561-324	Coupling incl. gasket, DN20, G1B - R $\frac{3}{4}$, 2 pcs.

Extensionsg

Article number	Description
1330-010	Extension excluding gaskets, 110 - 165 mm, G $\frac{3}{4}$ B - G1B, 1 pc. *
1330-012	Extension excluding gaskets, 110 - 220 mm, G $\frac{3}{4}$ B - G1B, 1 pc. *
1330-013	Extension excluding gaskets, 110 - 130 mm, G $\frac{3}{4}$ B - G1B, 1 pc. *
1330-015	Extension excluding gaskets, 110 - 130 mm, G $\frac{3}{4}$ B - G $\frac{3}{4}$ B, 1 pc.
1330-019	Extension excluding gaskets, 110 - 165 mm, G $\frac{3}{4}$ B - G $\frac{3}{4}$ B, 1 pc.

* Order 2 pieces per meter

Sensor nipples and pockets

Article number	Description
6556-491	R $\frac{1}{2}$ nipple for direct short sensor
6556-492	R $\frac{3}{4}$ nipple for direct short sensor

Ball valves

Article number	Description
6556-570	$\frac{1}{2}$ " ball valve with M10 connection for direct short temperature sensor
6556-571	$\frac{3}{4}$ " ball valve with M10 connection for direct short temperature sensor

Gaskets

Article number	Description
2210-131	Gasket for direct short temperature sensors, 1 pc.
2210-061	Gasket for G $\frac{3}{4}$ B (R $\frac{1}{2}$) flow sensor (coupling), 1 pc.
2210-062	Gasket for G1B (R $\frac{3}{4}$) flow sensor (coupling), 1 pc.

Please contact Kamstrup A/S for information on further accessories.

MULTICAL® 303

3.2 Configuration number

The software configuration of MULTICAL® 303 is defined on the basis of the configuration number. Below, an overview of the meter's configuration numbers is shown. Each part of the configuration number is described in more detail in the following paragraphs.

	A	B	CCC	DDD	L	RR	T	VVV
Flow sensor position								
Inlet	3							
Outlet	4							
Measuring unit								
GJ		2						
kWh		3						
MWh		4						
Flow sensor coding (see paragraph 3.2.3)								
Normal/high-resolution (7-digit)			4xx					
High resolution (8-digit)			5xx					
Display (see paragraph 3.2.4)								
Heat meter (standard)				210				
Heat/cooling meter (standard)				310				
Cooling meter (standard)				510				
Integration mode								
Adaptive mode (4-64 s)					5			
Normal mode (32 s)					6			
Fast mode (4 s)					7			
Data logger profile								
See paragraph 3.2.6						RR		
Encryption level								
Individual key							3	
Customer label								
See paragraph 3.2.8								xxxx
Communication configuration								
Communication hardware								
M-Bus (Selection in type number)								xxx
wM-Bus (Selection in type number)								yy
System configuration (wM-Bus)								
See paragraph 11.2.2								zzz
Datagram (M-Bus/wM-Bus)								
See paragraph 11.2.3								zzz

3.2.1 Flow sensor position >A<

The A-code indicates installation of the flow sensor in inlet or outlet. As the density and heat capacity of water vary with temperature, the calculator must correct this based on the installation position (A-code). Incorrect programming or installation leads to error of measuring. For further details on the installation of the flow sensor in inlet and outlet in heat and cooling installations, see paragraphs 4.2 and 4.6.

Flow sensor position	A-code
Inlet	3
Outlet	4

3.2.2 Measuring unit >B<

The B-code indicates the measuring unit used in the energy register. The options are GJ, kWh or MWh.

Measuring unit	B-code
GJ	2
kWh	3
MWh	4

3.2.3 Flow sensor coding >CCC<

The CCC-code optimises the display resolution for the selected flow sensor size. At the same time, the type approval regulations as to minimum resolution and maximum register overflow are observed. The CCC-codes are divided into 3 tables with 7-digit standard resolution, 7-digit high resolution and 8-digit high resolution.

Standard CCC-codes, 7 digits

CCC-table for MULTICAL® 303									
CCC no.	Number of decimals on display							q _p (m ³ /h)	Type 303-xXXxxxxxxxx
	kWh	MWh	GJ	m ³	l/h	m ³ /h	kW		
416	0	3	2	2	0	-	1	0,6	10
419	0	3	2	2	0	-	1	1,5	40-70
498	0	3	2	2	0	-	1	2,5	A0

CCC-codes with high resolution, 7 digits

CCC-table for MULTICAL® 303									
CCC no.	Number of decimals on display							q _p (m ³ /h)	Type 303-xXXxxxxxxxx
	kWh	MWh	GJ	m ³	l/h	m ³ /h	kW		
484	1	-	3	3	0	-	1	0,6	10
407	1	-	3	3	0	-	1	1,5	40-70
455	1	-	3	2	0	-	1	1,5	40-70
454	1	-	3	3	0	-	1	2,5	A0
459	1	-	3	2	0	-	1	2,5	A0

MULTICAL® 303

CCC-codes with high resolution, 8 digits

8-digit CCC-table for MULTICAL® 303									
CCC no.	Number of decimals on display							q _p (m ³ /h)	Type 303-xXXXXXXXX
	kWh	MWh	GJ	m ³	l/h	m ³ /h	kW		
584	1	-	3	3	0	-	1	0,6	10
507	1	-	3	3	0	-	1	1,5	40-70
555	1	-	3	2	0	-	1	1,5	40-70
598	1	-	3	3	0	-	1	2,5	A0
559	1	-	3	2	0	-	1	2,5	A0

The choice of 7 or 8 digits may influence the data communication

If the reading device has been hard coded to a given number of digits for the individual registers, there may occur errors in the data communication if you select, for example, 8 digits on the meter, while the reading device is hard coded to, for example, 7 digits.

This type of error most often occurs in systems in which meter and reading device use different communication types, e.g. a PLC system in which the communication to an M-Bus converter takes place via RS-232 and the communication to a MULTICAL® meter takes place via M-Bus. In case of suspicion that an error in the data communication is caused by this, it can be checked by changing the CCC code in MULTICAL® to a variant with another number of digits but of the same flow meter size.

To change the CCC code, an optical read-out head and METERTOOL are used.

3.2.4 Display code >DDD<

MULTICAL® 303 has 4 display loops: “USER loop”, “TECH loop”, “SETUP loop” and “TEST loop”. “TECH loop” contains all display views, and this loop is non-configurable. “USER loop” is, however, configurable and can be adapted to customer requirements by means of the DDD-code (display code). As a minimum, “USER loop” always comprises the meter’s legal readings.

The meter’s legal readings, e.g. energy and volume readings, are basically displayed as 7-digit or 8-digit values. The number of digits of the legal readings are configured with the CCC-code, see the previous paragraph.

The first digits of the three-digit DDD-code define the meter type comprised by the DDD-code in question. The table shows examples of a number of DDD-codes within each meter type. In the table, “1” indicates the first reading and the order will follow the digits. The display automatically returns to reading “1” 4 minutes after the last keystroke.

Please contact Kamstrup A/S for information on available display codes.

Display ref.	 Front key	Heat meter	Heat/cooling	Heat meter	Cooling meter	Heat/cooling
		DDD = 210	meter DDD = 310	DDD = 410	DDD = 510	meter DDD = 610
1.0	Heat energy (E1)	1	1	1		1
2.0	Cooling energy (E3)		2		1	2
3.0	Volume	2	3	2	2	3
4.0	Hour counter	3	4	3	3	4
5.0	t1 (Inlet)	4	5	4	4	5
6.0	t2 (Outlet)	5	6	5	5	6
7.0	t1-t2 ($\Delta\theta$) (- indicates cooling)	6	7	6	6	7
8.0	Flow (V1)	7	8	7	7	8
9.0	Thermal power (V1)	8	9	8	8	9
10.0	Info code	9	10	9	9	10
11.0	Customer number (N° 1)	10	11	10	10	11
12.0	Customer number (N° 2)	11	12	11	11	12
13.0	E8 (m ³ x t1)					
14.0	E9 (m ³ x t2)					
15.0	Heat energy (E1) Date of yearly logger (latest)					
16.0	Heat energy (E1) Data of yearly logger (latest)					
17.0	Heat energy (E1) Date of monthly logger (latest)					
18.0	Heat energy (E1) Data of monthly logger (latest)					
19.0	Cooling energy (E3) Date of yearly logger (latest)					
20.0	Cooling energy (E3) Data of yearly logger (latest)					
21.0	Cooling energy (E3) Date of monthly logger (latest)					
22.0	Cooling energy (E3) Data of monthly logger (latest)					
23.0	Volume (V1) Date of yearly logger (latest)					
24.0	Volume (V1) Data of yearly logger (latest)					
25.0	Volume (V1) Date of monthly logger (latest)					
26.0	Volume (V1) Data of monthly logger (latest)					
27.0	Heat energy (E1) High resolution					
28.0	Cooling energy (E3) High resolution					
29.0	Volume (V1) High resolution					
30.0	Software revision					
31.0	Software checksum					

MULTICAL® 303

3.2.5 Integration mode >L<

MULTICAL® 303 uses time-based integration, which means that accumulated volume and energy are calculated at fixed or variable time intervals. The time interval is configurable via the L-code and is independent of the water flow. Be aware that the choice of integration mode in combination with the choice of supply defines the battery lifetime of the meter. See paragraph 10.1 for information on the battery lifetime of the meter.

It is possible to choose between three integration modes: in all three modes, the meter's display turns off 8 minutes after the last keystroke. In the period in which the display is turned off, a segment (heart beat indication) will flash at an interval of 30 seconds to show that the meter is active.

Note Possible L-code options are configured via the country code of the meter.

Integration mode	L-code
Adaptive mode (4-64 s)	5
Normal mode (32 s)	6
Fast mode (4 s)	7

Note: Activating a key on the display changes the time interval to 4 seconds regardless of integration mode. 4 minutes after the latest activation of a key, the time interval returns to the interval based on the integration mode

Adaptive mode (4-64 s)

Adaptive mode is the meter's intelligent integration mode in which the time interval is adapted regularly. This mode combines the long battery lifetime obtained at Normal mode with the high measurement and calculation resolution obtained at Fast mode.

In case of a stable system, i.e. the system operates with a stable flow and power, the meter will operate at a time interval of 64 seconds. MULTICAL® 303 regularly measures if there are changes in flow and power and if this is the case, the time interval is reduced to 4 seconds, which means that the meter calculates the accumulated volume and energy every 4 second. Thus, a better resolution as well as better precision during changes in the system are obtained.

When the system is stable again, the meter gradually reverts to the 64-second time interval. MULTICAL® 303 reacts quickly to changes in the system by reducing the time interval to 4 seconds, but only reverts gradually to a 64-second time interval concurrently with the stabilisation of the system.

In adaptive mode, MULTICAL® 303 thus measures with a high resolution in the periods in which there are changes in the system and where accurate measurements are required and conserves battery lifetime in the periods in which the system is stable.

Adaptive mode can be used for all installations, also installations with tap water exchanger. According to EN 1434-1, it is, however, recommended to use a meter with constantly quick reaction as in "Fast mode".

Normal mode (32 s)

In normal mode, the integration interval is set to 32 seconds, which means that the meter calculates accumulated volume and energy every 32 second.

Normal mode is recommended for installations with hot water container and similar installations.

Fast mode (4 s)

In fast mode, the integration interval is set to 4 seconds, which means that the meter calculates accumulated volume and energy every 4 second.

Fast mode is recommended for all installations, also installations with tap water exchanger. Fast mode (4 s) meet the requirements for "Fast response meter" in EN 1434.

3.2.6 Data logger profile >RR<

MULTICAL® 303 has a permanent memory (EEPROM) in which the results of various data loggers are saved. The data logger is programmable. The required data logger profile is selected via the RR-code of the configuration number. Unless otherwise stated by the customer, the RR-code is set to 30, which is the default data logger profile (based on the data logger in MULTICAL® 403). If data logging of other registers, different intervals and logging depths are required, more data logger profiles can be composed to match individual requirements.

The programmable data logger includes the following six data loggers:

- Yearly logger
- Monthly logger
- Daily logger
- Hour logger
- Minute logger 1
- Minute logger 2

If the data logger profile is changed to another profile after commissioning of the meter, the saved logged values are deleted from the meter.

Both data logger registers and logging depth are programmable, and individual logger profiles can be composed to match customer requirements. An overview of available data logger profiles for MULTICAL® 303 can be found below in the same paragraph. The data logger profiles are based on, but not identical with, the data logger profiles in MULTICAL® 403.

Standard (RR 30)

Register ID (dec)	Register name	Year	Month	Day	Hour	Minute 1	Minute 2
Logningsinterval		1y	1m	1d	1h	15m	1m
Loggerdybde		20	36	460	72	96	360
1003	Date (yy.mm.dd)	x	x	x	x	x	x
1002	Time (hh.mm.ss)	x	x	x	x	x	x
60	Heat energy E1	x	x	x	x	x	x
63	Cooling energy E3	x	x	x	x	x	x
97	Energy E8	x	x	x	x	x	x
110	Energy E9	x	x	x	x	x	x
68	Volume V1	x	x	x	x	x	x
369	Info bits	x	x	x	x	x	x
123	Flow V1 max year date	x					
124	Flow V1 max year	x					
125	Flow V1 min year date	x					
126	Flow V1 min year	x					
127	Power max year date	x					
128	Power max year	x					
129	Power min year date	x					
130	Power min year	x					
138	Flow V1 max month date		x				
139	Flow V1 max month		x				
140	Flow V1 min month date		x				
141	Flow V1 min month		x				
142	Power max month date		x				
143	Power max month		x				
144	Power min month date		x				
145	Power min month		x				

MULTICAL® 303

Register ID (dec)	Register name	Year	Month	Day	Hour	Minute 1	Minute 2
379	t1 time average day			x			
380	t2 time average day			x			
381	t1 average hour				x		
382	t2 average hour				x		
1004	Operating hours	x	x	x	x	x	x
175	Error hour counter	x	x	x	x	x	x
86	t1 actual (2 decimals)		x	x	x	x	x
87	t1 actual (2 decimals)		x	x	x	x	x
89	t1_t2 diff. temp. (2 decimals)		x	x	x	x	x
74	Flow V1 actual		x	x	x	x	x
80	Power E1/E3 actual		x	x	x	x	x

Current values (RR 11)

Register ID (dec)	Register name	Year	Month	Day	Hour	Minute 1	Minute 2
Logging interval		1y	1m	1d	1h	15m	m
Logging depth		20	36	460	600	300	
1003	Date (yy.mm.dd)	x	x	x	x	x	
1002	Time (hh.mm.ss)	x	x	x	x	x	
60	Heat energy E1	x	x	x	x	x	
63	Cooling energy E3	x	x	x	x	x	
97	Energy E8	x	x				
110	Energy E9	x	x				
68	Volume V1	x	x	x	x	x	
369	Info bits	x	x	x	x		
123	Flow V1 max year date	x					
124	Flow V1 max year	x					
125	Flow V1 min. year date	x					
126	Flow V1 min. year	x					
127	Power max year date	x					
128	Power max year	x					
129	Power min. year date	x					
130	Power min. year	x					
138	Flow V1 max month date		x				
139	Flow V1 max month		x				
140	Flow V1 min. month date		x				
141	Flow V1 min. month		x				
142	Power max month date		x				
143	Power max month		x				
144	Power min. month date		x				
145	Power min. month		x				
379	t1 time average day			x			
380	t2 time average day			x			
381	t1 time average hour				x		
382	t2 time average hour				x		
1004	Operating hours	x	x				
175	Error hour counter	x	x				
86	t1 actual (2 decimals)			x	x	x	
87	t2 actual (2 decimals)			x	x	x	
89	t1_t2 diff. temp. (2 decimals)			x	x	x	
74	Flow V1 actual			x	x	x	
80	Power E1/E3 actual			x	x	x	

MULTICAL® 303

Ludwig (RR 12)

Register ID (dec)	Register name	Year	Month	Day	Hour	Minute 1	Minute 2
Logging interval		1y	1m	1d	1h	m	m
Logging depth		20	36	460	600		
1003	Date (yy.mm.dd)	x	x	x	x		
1002	Time (hh.mm.ss)	x	x	x	x		
60	Heat energy E1	x	x	x	x		
63	Cooling energy E3	x	x	x	x		
97	Energy E8	x	x	x			
110	Energy E9	x	x	x			
68	Volume V1	x	x	x	x		
369	Info bits	x	x	x	x		
123	Flow V1 max year date	x					
124	Flow V1 max year	x					
125	Flow V1 min. year date	x					
126	Flow V1 min. year	x					
127	Power max year date	x					
128	Power max year	x					
129	Power min. year date	x					
130	Power min. year	x					
138	Flow V1 max month date		x				
139	Flow V1 max month		x				
140	Flow V1 min. month date		x				
141	Flow V1 min. month		x				
142	Power max month date		x				
143	Power max month		x				
144	Power min. month date		x				
145	Power min. month		x				
379	t1 time average day			x			
380	t2 time average day			x			
381	t1 time average hour				x		
382	t2 time average hour				x		
1004	Operating hours	x	x				
175	Error hour counter	x	x				

3.2.7 Encryption level >T<

MULTICAL® 303 must be ordered with encrypted data transmission between meter and reading system using wM-Bus. Data is encrypted with 128 bit AES counter mode encryption. Data transmission can be encrypted with either a common or an individual encryption key.

If you select individual encryption key (T-code 3), the reading system must know the encryption key of the individual meter to read the meter. The encryption key is sent to the customer and then “paired” with the serial number of the individual meter in the reading system.

If you select common encryption key (T-code 2), the key can be used for reading a customer-specific number of meters. The key is created by Kamstrup A/S. A customer can have several encryption keys, e.g. one for each meter type.

Note: Due to GDPR, the common encryption key is **no longer** provided.

The encryption level is configured as part of the meter’s configuration number via the T-code. Upon receipt of order, the T-code is by default configured to 3 - individual encryption key (unless otherwise informed by the customer). The encryption level can be configured when submitting the order. The encryption level cannot be changed upon delivery.

Encryption level	T-code
Encryption with common key (customer-specific)	2
Encryption with individual key	3

Encryption keys can be downloaded from Kamstrup’s customer portal “My Kamstrup” at www.kamstrup.com. Encryption keys are automatically entered in USB Meter Reader and READY.

3.2.8 Customer label >VVV<

A 20x50 mm customer label can be printed on the meter’s front. The customer label to be printed on the meter’s front is determined by the VVVV-code. The customer label can show utility logo, a bar code or the like. By default, the meter’s serial number is written in the customer label field.

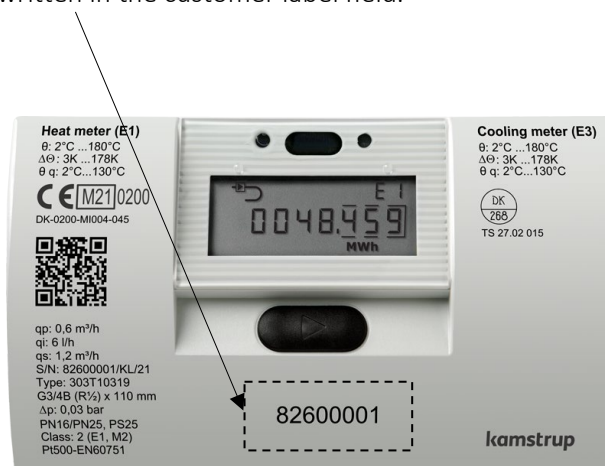

Please contact Kamstrup A/S for information about possible customer labels as well as the creation of a new customer label.

	Automatic	To be stated in order	Default
Offset of t1 and t2 ($\pm 0,99$ K) ⁴ (See paragraph 7.2)	To be entered on the basis of R_0 of the sensor element as well as the cable resistance. If no sensor data is available, offset is set to 0,00 K.	-	-
DST (Daylight Saving Time) (See paragraph 7.9.)	-	Activated / Deactivated	Depending on country code

¹ Serial number (factory-set unique serial number) is written on the meter and cannot be changed after factory configuration.

² If yearly target date 2 (MM.DD) and monthly target date 2 (DD) are set to 00.00 and 00, respectively, these target dates are disabled, and the meter just uses yearly target date 1 and monthly target date 1.

³ $\theta_{hc} = 250,00$ °C disconnects the function. In all other meter types than 6, θ_{hc} is disabled and cannot be enabled upon delivery.

⁴ At order submission, you can select "Fixed M-Bus address", which means that all meters included in the order will be configured with the same primary M-Bus address.

⁵ R_0 is the resistance value of the sensor element in ohm (Ω) at 0 °C.

3.4 Serial number and extended availability

The serial number consists of 8 digits (xxxxxxx/WW/yy), a two-digit device code for extended availability (xxxxxxx/WW/yy) as well as the production year (xxxxxxx/WW/yy). The serial number (factory-set unique serial number) is written on the meter and cannot be changed after factory programming.

You need the encryption key of a specific meter to be able to read the meter via wireless M-Bus. Encryption keys are sent directly from “My Kamstrup” at Kamstrup's website. Customers who buy their meters from wholesalers can download their encryption keys directly from “My Kamstrup” where the customer can create a user profile without contacting Kamstrup A/S. Next, the customer enters the meter’s serial number as well as the two digits (device code) for extended availability and downloads the encryption key. The two digits have been introduced to provide customers who buy Kamstrup meters from a wholesaler with a secure method for obtaining the necessary encryption keys.

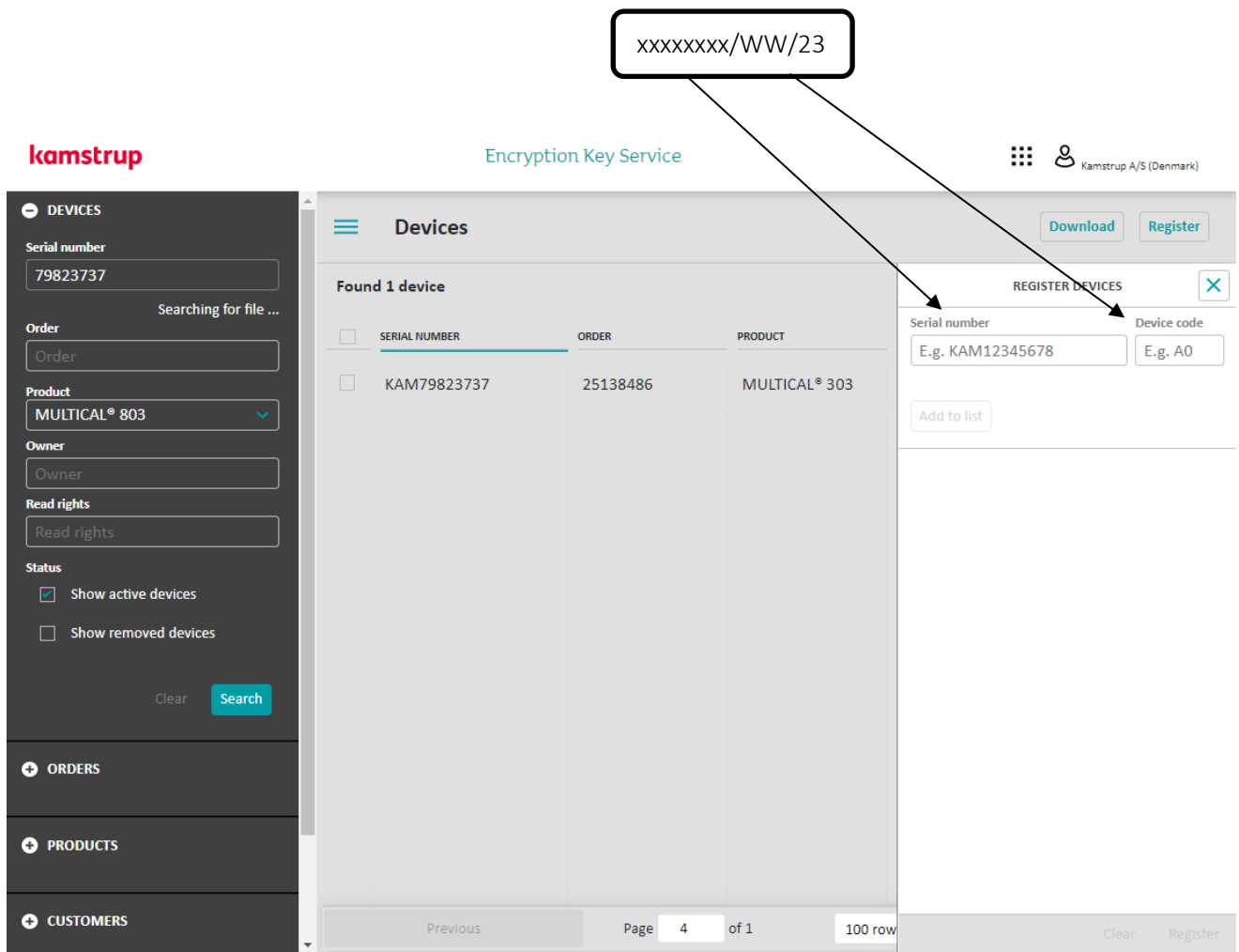

3.5 Target date

MULTICAL® 303 can be configured with up to two yearly target dates and two monthly target dates. These dates determine on which date data is to be logged (saved) in the meter's interval logger. To avoid confusion about which time of the day the meter saves data, MULTICAL® 303 also, in addition to the date, includes a time stamp for the logging. This time stamp is not included in former meters such as MULTICAL® 402, which simply stamps data with a date. This difference also means that the date stamps of the two meters vary in spite of the fact that both meters are configured with a target date, e.g. 01.01 [MM.DD]. Note that although the date stamps of the two meters are different, both meters will in practice log (save) data at the same time. This is illustrated by the following example:

	<i>MULTICAL® 402/602/801</i>	<i>MULTICAL® 303/403/603/803</i>
<i>Yearly target date</i> [MM.DD]	01.01	01.01
<i>Monthly target date</i> [DD]	01	01
<i>Date/time</i> [20YY.MM.DD/ hh.mm.ss]	2018.12.31 / 24.00.XX ¹	2019.01.01 / 00.00.XX

¹ Note that it is not possible to read out this time stamp from the meter.

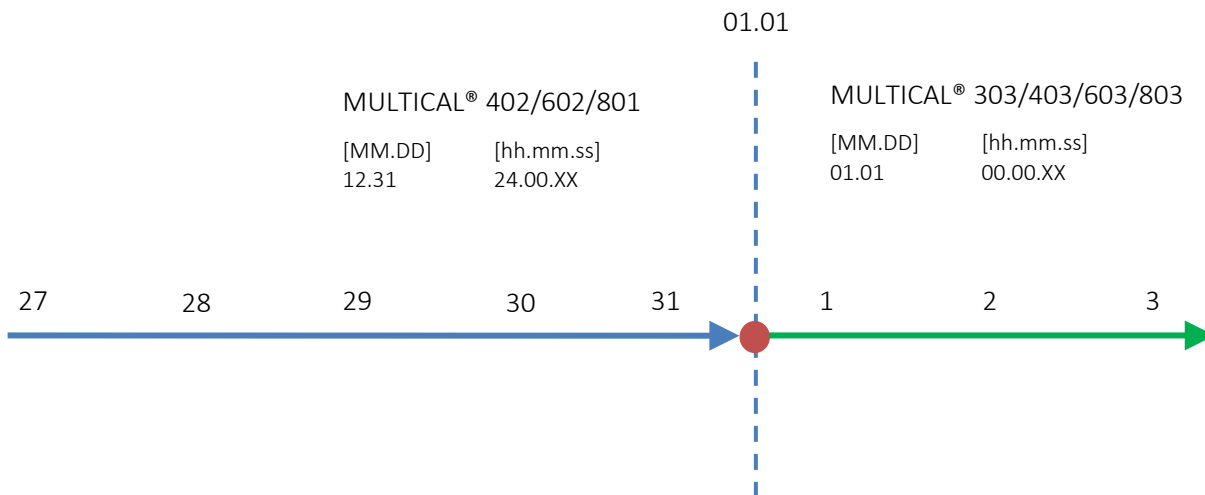

When using MULTICAL® 303 together with systems that are dependent on data being logged with a given target date, it is important to select this date as target date in the meter's configuration. The target date can be configured both via the meter's front key in "SETUP loop" and via MeterToolX/HCW. See paragraph 6.3 and the technical description of MeterTool HCW, 5512-2067. If the target date is required to be set to the last day of the month, the monthly target date [DD] is set to 31. MULTICAL® 303 automatically logs on the last day of months with less than 31 days.

4 Installation

4.1 Installation requirements

Prior to installation of MULTICAL® 303, the installation should be flushed while a fitting piece replaces the meter. Remove the adhesive wafers from the meter's inlet and outlet and mount the flow sensor with couplings. New fibre gaskets in original quality must always be used.

If other couplings than the original ones from Kamstrup A/S are used, you must make sure that the threaded lengths of the couplings do not prevent proper tightening of the sealing surface.

The meter is configured for mounting of flow sensor in inlet or outlet before commissioning, see paragraph 6.3 about "SETUP loop". The flow direction is indicated by an arrow on the flow sensor.

To avoid cavitation, the back pressure at the flow sensor (the pressure at the flow sensor outlet) must typically be minimum 1 bar at q_p and minimum 2 bar at q_s . This applies to temperatures up to approx. 80 °C, see paragraph 4.5 about operating pressure.

When the installation has been completed, water flow can be turned on. The valve on the flow sensor's inlet side must be opened first.

The flow sensor must not be exposed to lower pressure than the ambient pressure (vacuum).

Permissible operating conditions

Ambient temperature:	5...55 °C (indoors). Max 30 °C for optimum battery lifetime
Media temperature of heat meter:	2...130 °C with calculator mounted on a wall 15...90 °C with calculator mounted on the flow sensor
Media temperature of cooling meter:	2...50 °C with calculator mounted on a wall
Media temperature of heat/cooling meter:	2...130 °C with calculator mounted on a wall
Installation pressure:	1,0...25 bar for threaded meters (see paragraph 4.5)

Service

Neither welding nor freezing is allowed whilst the meter is mounted. Before initiating the work, the meter must be dismantled.

To facilitate the exchange of the meter, stop valves should always be mounted on both sides of the meter.

Under normal operating conditions, no pipe strainer is required in front of the meter.

4.2 Inlet conditions

Kamstrup's flow sensors requires neither straight inlet nor straight outlet to comply with the measuring instruments directive (MID) 2014/32/EU, OIML R75:2002 and EN 1434:2015. A straight inlet section is only required in case of heavy flow disturbances before the meter. It is recommended to follow the guidelines in CEN/TR 13582, "Heat meter installation – Some guidelines for selecting, installation and operation of heat meters" that provides general information about installation.

Optimum position can be obtained by taking the below-mentioned installation methods into account.

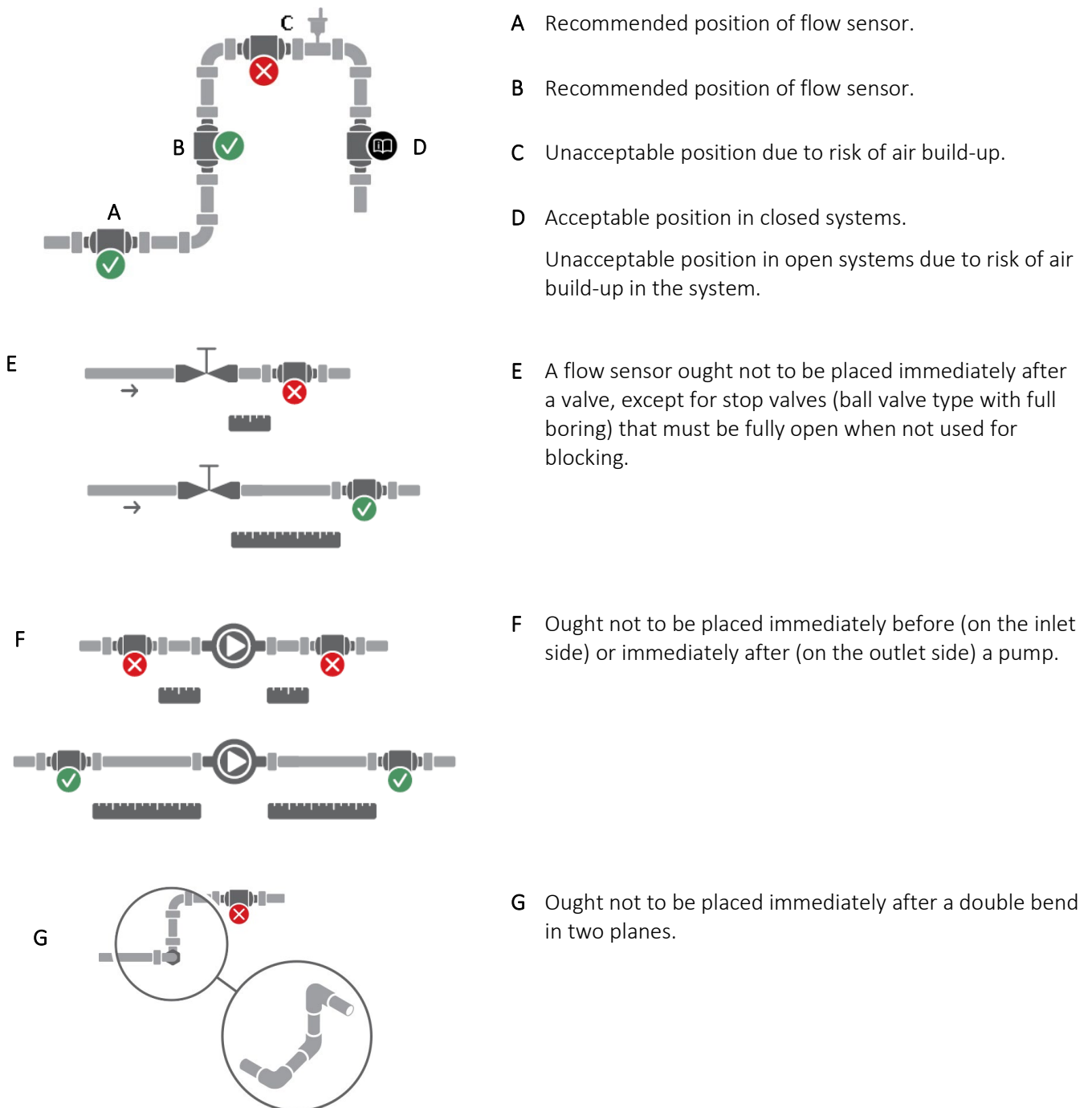
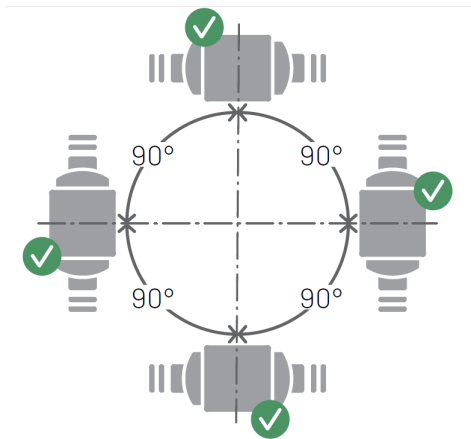

Figure 2 General installation recommendations for flow sensors.

4.3 Orientation of Kamstrup’s flow sensors

The recommended orientation of the flow sensor in an installation takes into account the flow sensor’s metrological sensitivity towards orientation, e.g. due to orientation-dependent flow profiles; poor water quality of district heating water, e.g. impurities that may occur in the flow sensor; air in the system and environmental requirements, e.g. in case of condensation. The recommendations may vary for individual types due to their differences in construction.

4.3.1 General recommendations



Kamstrup’s flow sensors can be mounted horizontally, vertically or at an angle.

If the flow sensors are mounted vertically, they can be turned $\pm 360^\circ$ around the pipe axis.

Important

The plastic box must be placed on the side (at horizontal mounting). See below for further information.

Figure 3 Mounting of Kamstrup flow sensors. Vertically, horizontally or at an angle.

At horizontal mounting, Kamstrup’s flow sensors can be turned around the pipe axis. Acceptable rotation angles of the various types of Kamstrup flow sensors can be seen on the following page.

At media temperatures above 90 °C or below the ambient temperature, i.e. for cooling installations, the calculator may not be mounted on the flow sensor. Instead wall-mounting is recommended. As a result, the orientation of the flow sensor in a cooling installation does not require taking into account the readability of the calculator's display and can thus be solely limited to the optimum orientation of the flow sensor.

4.3.2 Heat installation recommendations



Heat installations

Meter housing with thread with $q_p \leq 2,5 \text{ m}^3/\text{h}$

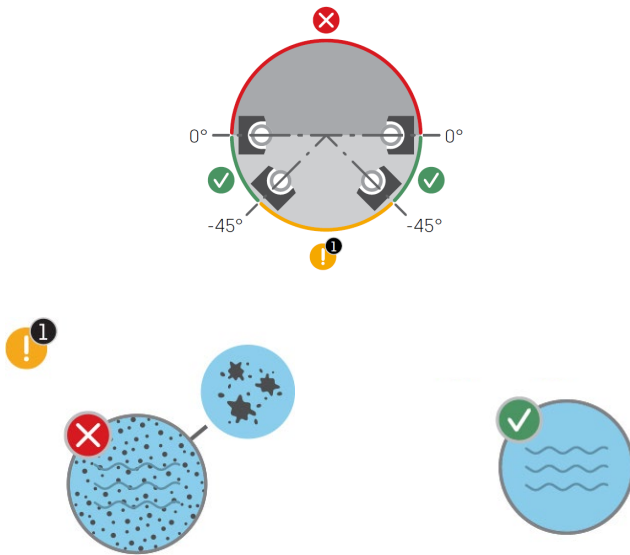

Figure 4. Acceptable orientation of Kamstrup's flow sensors around the pipe axis in heat installations at horizontal mounting. Meter housing with thread with $q_p \leq 2,5 \text{ m}^3/\text{h}$.

Note Orientations marked with "!" are accepted provided that the below-mentioned condition is met:

- (1) District heating water must be clean and without impurities. Impurities may settle onto the transducers of the flow sensor, which affects their ability to register and send the ultrasound signal.

4.3.3 Recommendations for cooling and combined heat/cooling installations



Cooling and combined heat/cooling installations

Meter housing with thread with $q_p \leq 2,5 \text{ m}^3/\text{h}$



(a)

Figure 5. Recommended orientation of Kamstrup's flow sensors around the pipe axis at horizontal mounting for cooling and combined heat/cooling. (a) Meter housing with thread with $q_p \leq 2,5 \text{ m}^3/\text{h}$.

In general: District heating and cooling water must be free from air. Air bubbles will affect the ultrasound signal significantly. If there is a risk of air, all flow sensors are mounted as in position (a) with the transducers on the side.

4.3.4 Recommendations for directly mounted temperature sensors

When mounting a temperature sensor directly in the outlet of the flow sensor, the acceptable orientations of the temperature sensor must be taken into account. For heat installations (*Figure 6 (a)*), the orientation of a temperature sensor is not important as long as a homogeneous temperature distribution can be assumed, i.e. all orientations are accepted. For cooling installations (*Figure 6 (b)*), it must be avoided that water gets into the sensor element. Thus, a temperature sensor is ideally mounted from the bottom with the end pointing upwards and is then turned to a horizontal position.



Figure 6. Acceptable orientation of a temperature sensor in (a) a heat and (b) a cooling installation.

These recommendations for mounting temperature sensors are in accordance with the recommendations for mounting flow sensors as shown in *Figure 4* and *Figure 5*. Although a temperature sensor can be mounted directly in a flow sensor for a cooling installation, which is mounted in a riser pipe, it may not be mounted in a flow sensor for a cooling installation mounted in a drainage pipe.

Installation examples:

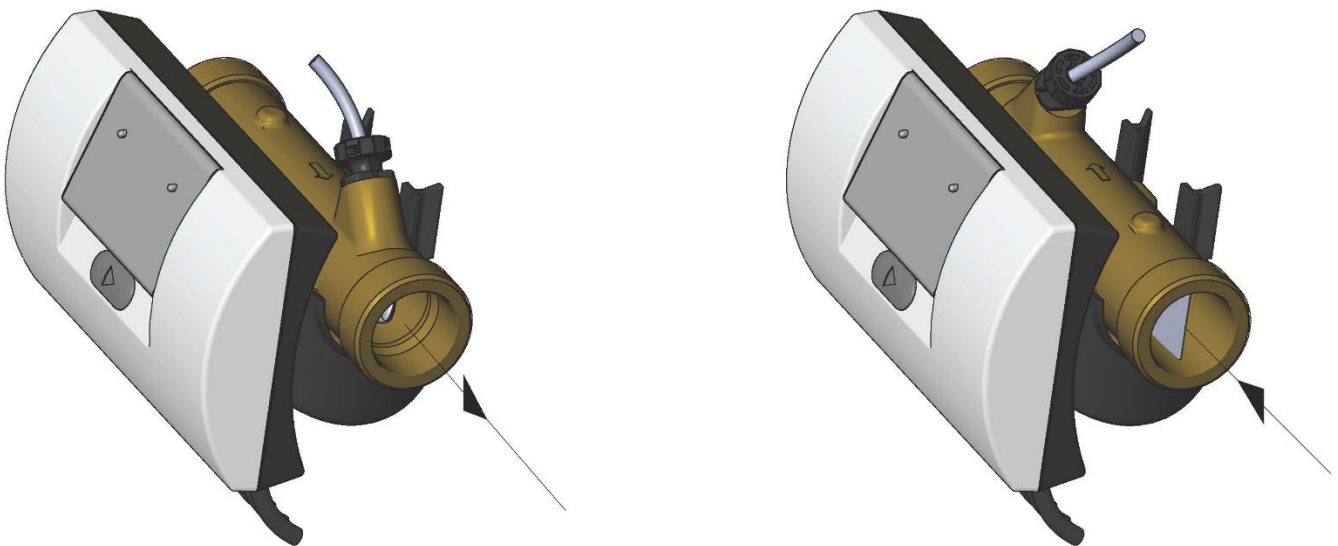
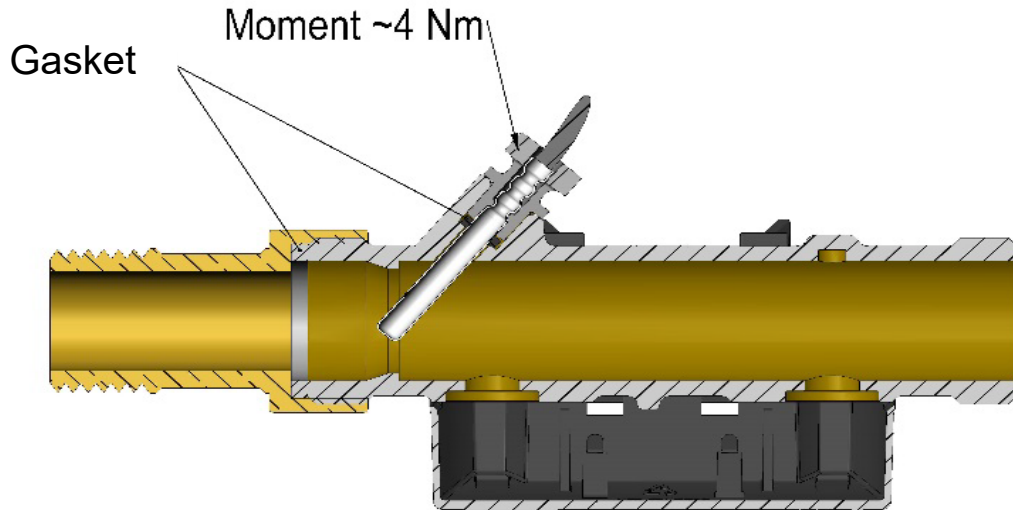

Figure 7: Coupling meter



Mounting of couplings as well as temperature sensor mounted in MULTICAL® 303 flow part

The flow sensor and the temperature sensor may be installed in both PN16 and PN25 installations. Any supplied extensions and couplings can be used for both PN16 and PN25.

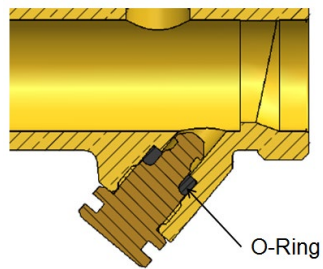
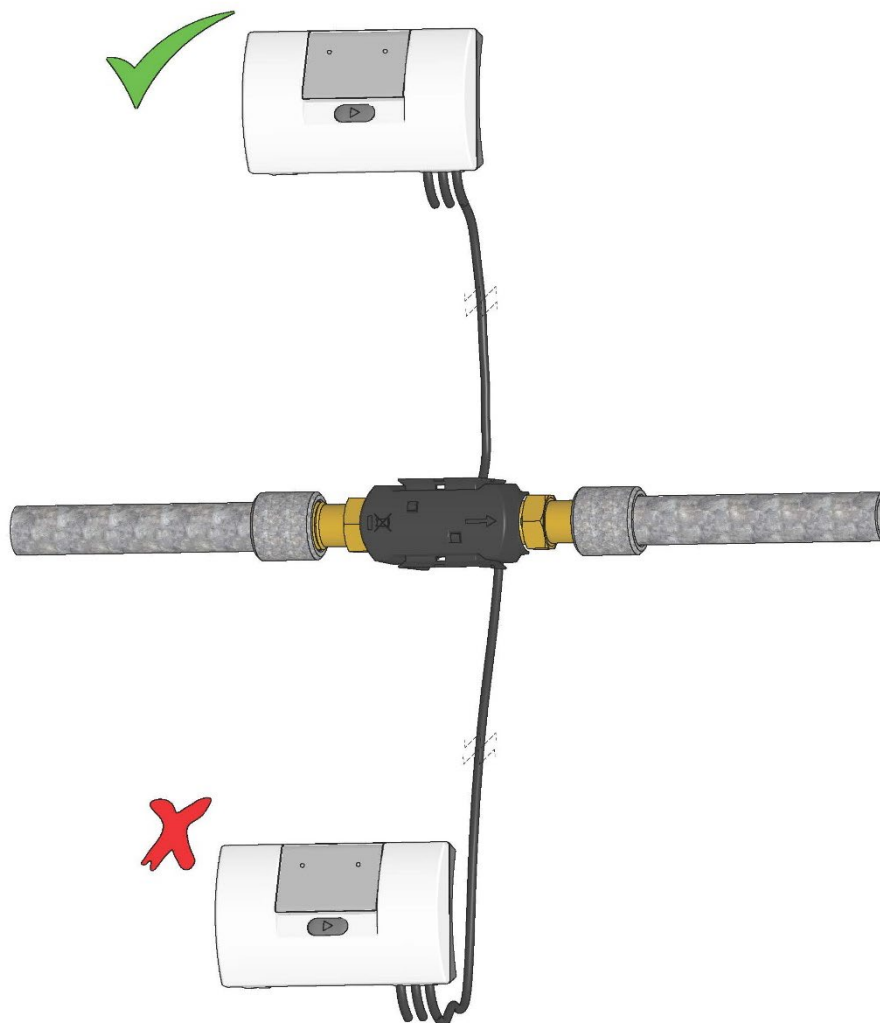

Figure 8

A blind plug can be delivered that can be used if the sensor is removed from the flow sensor and installed in, for example, a sensor pocket.

4.4 Calculator position

When the flow sensor is installed in humid or condensing environments, the calculator must be placed higher than the flow sensor.



4.5 Operating pressure for MULTICAL® 303

In connection with installation, it has proven to be appropriate to operate with at least the pressure stated in *Table 2*.

Nominal flow q_p [m ³ /h]	Recommended back pressure [bar]	Max flow q_s [m ³ /h]	Recommended back pressure [bar]
0,6...2,5	1	1,2...5,0	2

*Table 2: Recommended back pressure with various flow sensor sizes.
Values in the table apply to temperatures up to approx. 80 °C*

The purpose of the recommended back pressure is to avoid measuring errors as a result of cavitation or air in the water. Cavitation does not necessarily take place in the flow sensor itself, but can also occur as air bubbles created by cavitating pumps and regulating valves mounted before the flow sensor. It can take considerable time until such bubbles have been dissolved in the water.

In addition, the water can include dissolved air. The amount of air that can be dissolved in water depends on pressure and temperature. This means that air bubbles can be formed due to a pressure drop in the installation, e.g. caused by a velocity increase in a contraction or above the sensor.

The risk of influence from the above is reduced by maintaining a fair pressure in the installation.

In relation to *Table 2*, the steam pressure at current temperature must also be considered. The values in the table apply to temperatures up to approx. 80 °C. In case of higher temperatures, the graph in *Diagram 2* applies. Furthermore, it must be taken into consideration that the mentioned pressure is the back pressure at the flow sensor outlet and that the pressure is lower in a contraction than before one, e.g. in case of cones. This means that the pressure may differ from the pressure at the flow sensor if measured elsewhere in the installation.

The explanation of pressure drop due to an increase in velocity is found by combining the continuity equation and Bernoulli's equation. The total energy from the flow will be the same at any cross section.

It can be reduced to: $P + \frac{1}{2}\rho v^2 = \text{constant}$.

where: P = pressure, ρ = density, v = velocity.

When dimensioning the flow sensor, the above must be taken into account, especially if the meter is used in the area between q_p and q_s , described in EN 1434, as well as in case of heavy pipe contractions.

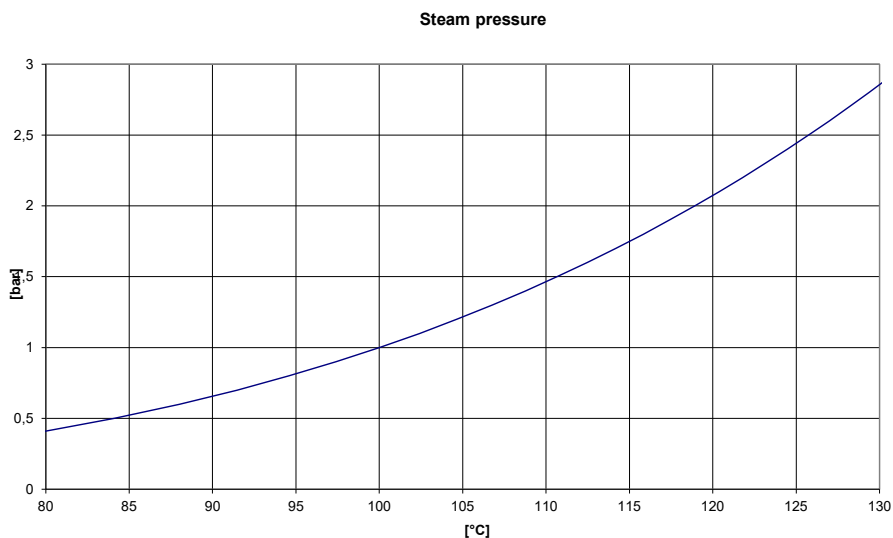

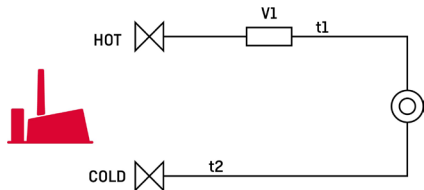

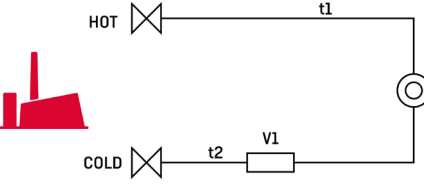

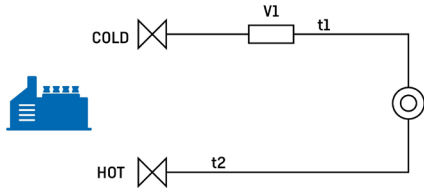

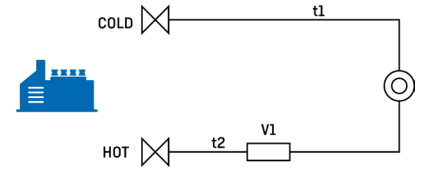

Diagram 2. Steam pressure as a function of the temperature

4.6 Mounting in inlet or outlet

MULTICAL® 303 is configured for mounting of the flow sensor in either inlet or outlet. In the display, the flow sensor position is indicated by a symbol, subadjcently the A-code of the program number is selected as 3 or 4 for flow sensor mounting in inlet and outlet, respectively. The table below shows the installation conditions of heat meters and cooling meters:

Formula	k-factor	A-code and Display	Hot pipe	Cold pipe	Installation
Heat meter $E1=V1(t1-t2)k$	k-factor with t1 and V1 in inlet	A-code= 3 Display: 	V1 and t1	t2	
	k-factor with t2 and V1 in outlet	A-code= 4 Display: 	t1	V1 and t2	
Cooling meter $E3=V1(t2-t1)k$	k-factor with t1 and V1 in inlet	A-code= 3 Display: 	t2	V1 and t1	
	k-factor with t2 and V1 in outlet	A-code= 4 Display: 	V1 and t2	t1	

4.7 EMC conditions

MULTICAL® 303 has been designed and CE-marked according to EN 1434 Class A (corresponding to Electromagnetic environment: Class E1 of the Measuring Instruments Directive) and can thus be installed in both domestic and industrial environments.

All signal cables must be drawn separately and not parallel to, for example, power cables or other cables with the risk of inducing electromagnetic interference. There must be a distance of at least 25 cm between signal cables and other installations.

4.8 Climatic conditions

MULTICAL® 303 is designed for indoor installation with ambient temperatures from 5...55 °C, however max. 30 °C to obtain optimal battery lifetime. Protection class IP65 of the calculator allows splashes of water, but the calculator must not be submerged. The protection class of the flow sensor is IP68, which means that it withstands submersion.

4.9 Sealing

According to EN 1434, MULTICAL® 303 must have protection devices, which can be sealed to the effect that after sealing, both before and after the heat meter has been correctly installed, it is impossible to dismount, remove or change the heat meter or its adjustment devices without visibly damaging meter or sealing. Correct sealing of MULTICAL® 303 includes two levels, installation sealing and verification sealing; a breaking of the sealing has different consequences on each level.

Installation sealing

Having completed the installation of MULTICAL® 303, installation sealing is the last thing to be done. The installation seal is the 'outermost' sealing level to be completed by the installer/utility. The installation sealing must ensure that the flow sensor and temperature sensors cannot be dismantled without visible signs that a separation has taken place. In practice, the installation sealing can be done by means of wire and seal, sealing label or a combination of these. The sealing is the utility's security that unauthorized persons cannot, undiscovered, change the installation around the meter. Breaking the installation sealing alone does not influence the meter's possibility of renewed installation sealing or the fact that it is legal in relation to its approval and verification.

Installation sealing and "SETUP loop"

The possibility of bringing MULTICAL® 303 into "SETUP loop" after installation requires that the plastic seal marked "SETUP" on the rear side of the calculator is broken and that the contact points underneath are short-circuited. Thereafter, "SETUP loop" can be accessed. The broken "SETUP" seal has the same level as the installation seal and can subsequently be restored with a sealing label. Sealing labels can be requested from Kamstrup A/S on order number 2008-727.

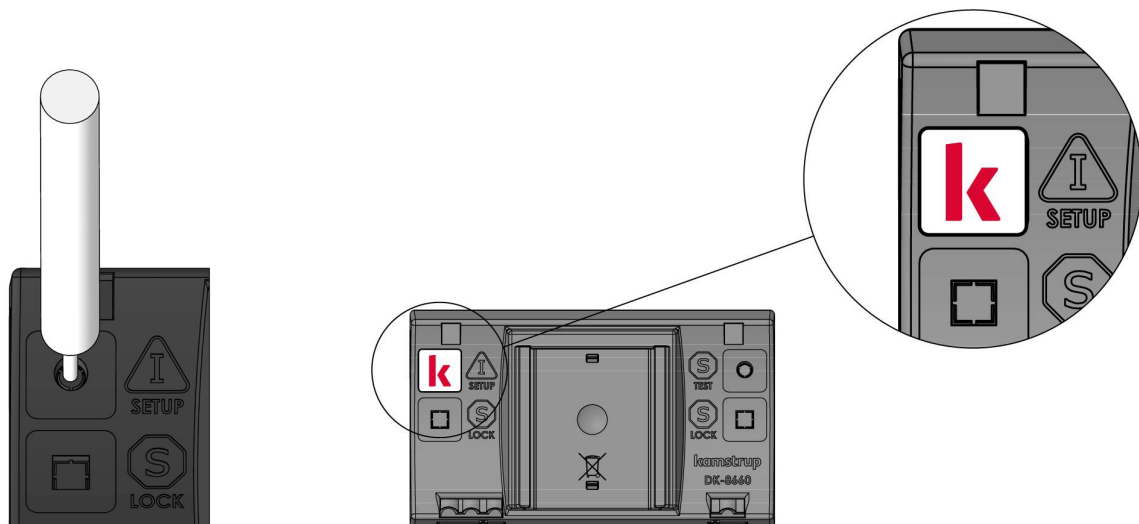

Verification seal

The verification sealing of MULTICAL® 303 consists of both mechanical and electronical sealing. The verification seals marked "LOCK" and "TEST" are placed on the rear side of the calculator. These seals can be seen as the "innermost" sealing level, which may only be broken by authorized laboratories in connection with test and reverification of the meter. If the meter is to be used for legal operation in relation to approval and verification after breaking of the verification sealing, the broken seals must be resealed. The sealing may only be carried out by an authorized laboratory using the sealing mark (void label) of the laboratory.

4.10 Pressure loss

The pressure loss in a flow sensor is stated as maximum pressure loss at q_p . According to EN 1434, the maximum pressure loss must not exceed 0,25 bar.

The pressure loss in a meter increases with the square of the flow and can be stated as:

$$Q = kv \times \sqrt{\Delta p}$$

where:

Q = the volume flow [m³/h]

kv = volume flow rate at 1 bar pressure loss [m³/h]

Δp = pressure loss [bar]

Curve	q_p [m ³ /h]	Nom. diameter [mm]	$\Delta p@q_p$ [bar]	kv	$q@0,25$ bar [m ³ /h]
A	0,6	DN15/DN20	0,03	3,46	1,7
B	1,5	DN15/DN20	0,09	4,89	2,4
C	2,5	DN20	0,09	8,15	4,1

Table 3: Pressure loss table

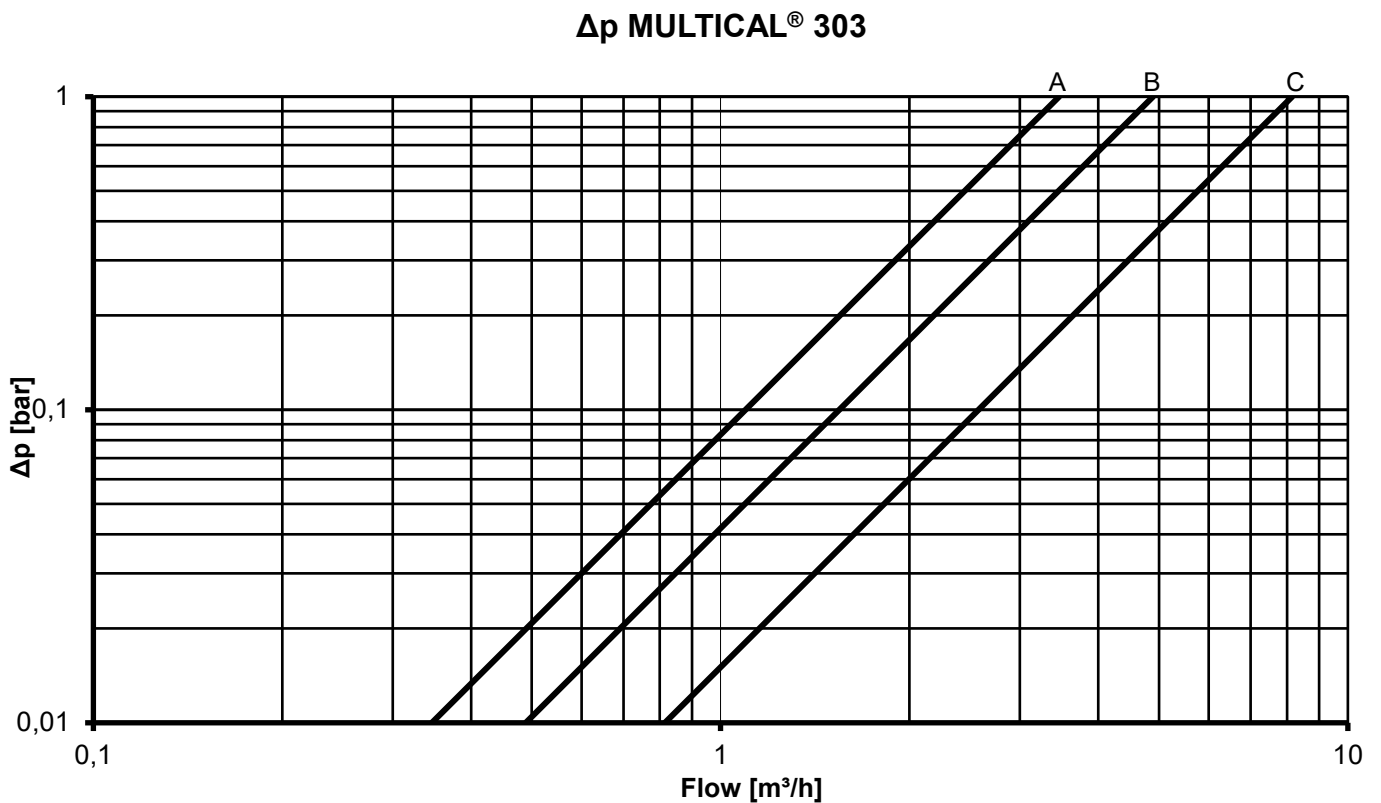

Diagram 3: Pressure loss graphs

5 Dimensioned sketches

Note All values are stated in [mm]

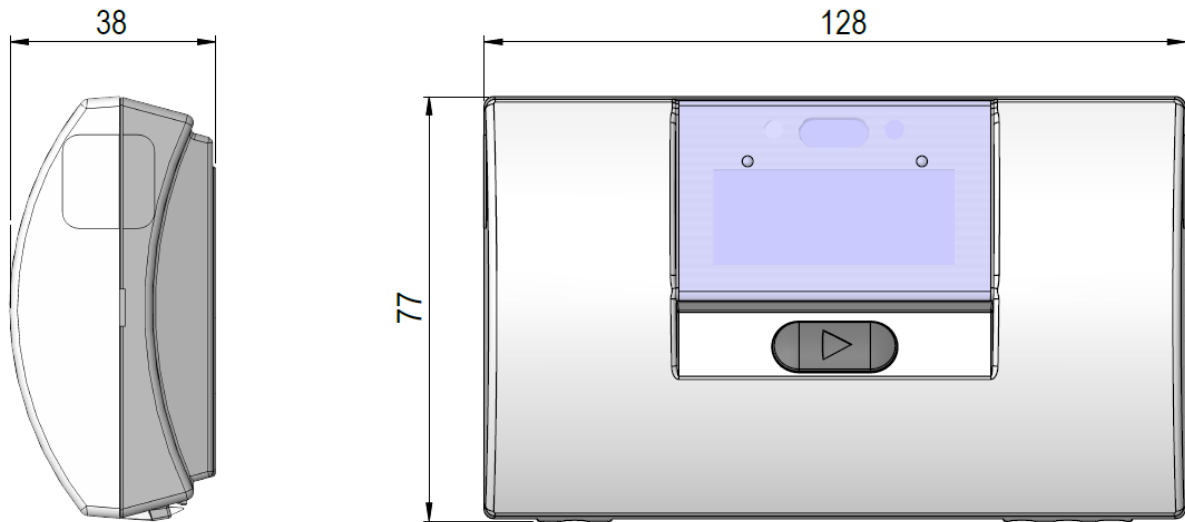

Figure 9: Mechanical measurements of calculator

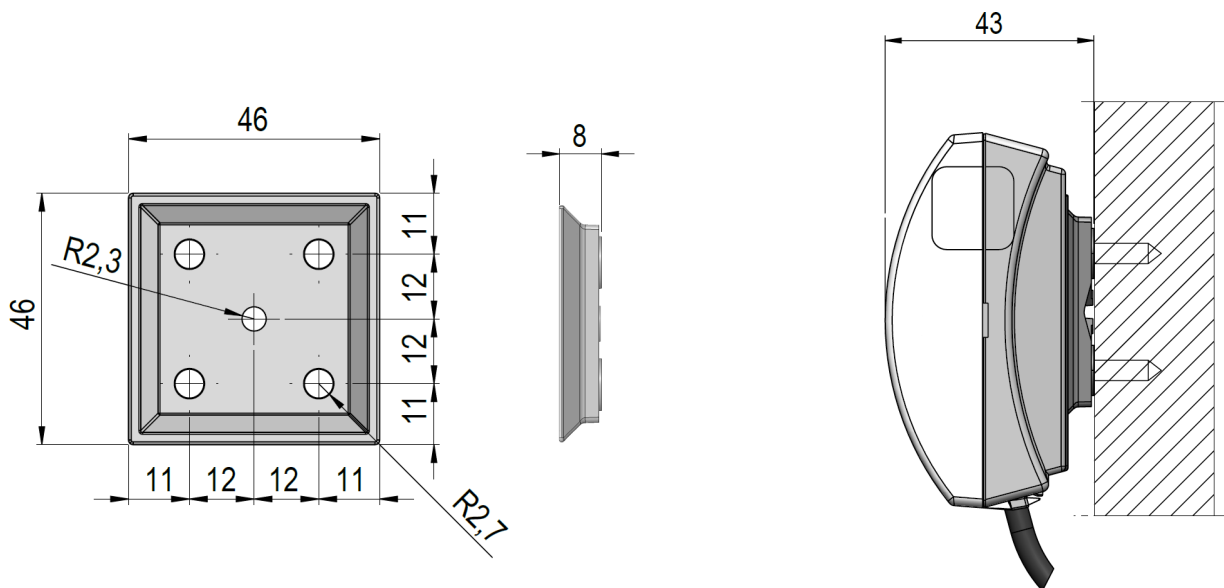

Figure 10: Wall bracket

Figure 11: Mounted with wall bracket

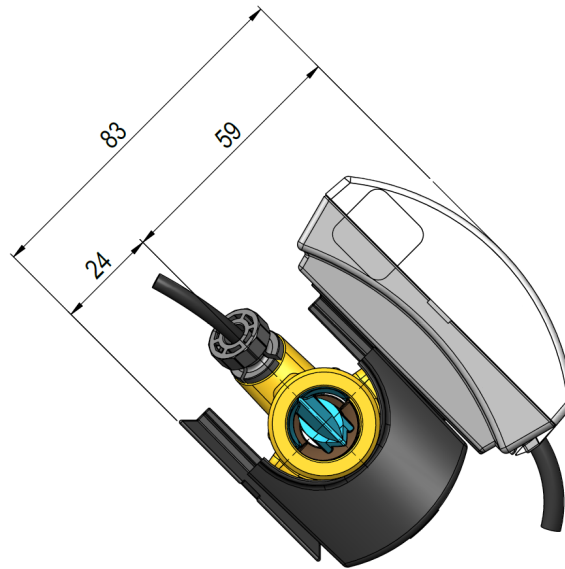

Figure 12: Complete MULTICAL® 303 with calculator mounted on flow part

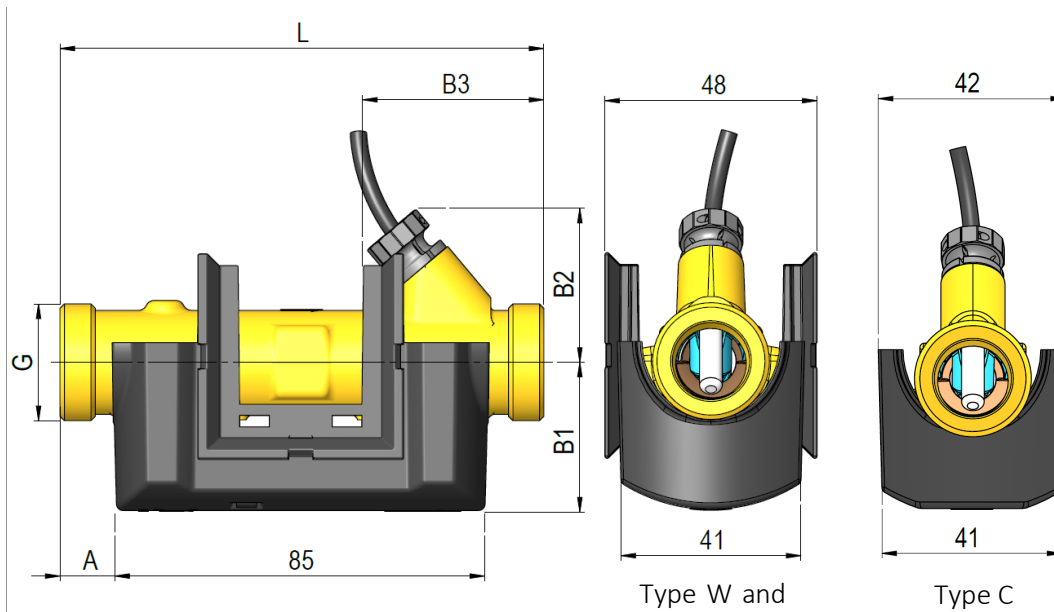

Figure 13: Flow sensor with G $\frac{3}{4}$ and G1 thread connection

Thread EN ISO 228-1

Nominal flow q_p [m ³ /h]	Thread G	L	A	B1	B2	B3	Weight approx. [kg] ¹
0,6	G $\frac{3}{4}$	110	12	35	32	38	0,7
1,5	G $\frac{3}{4}$	110	12	35	32	38	0,7
1,5	G1	130	22	38	38	48	0,8
2,5	G1	130	22	38	38	48	0,8

¹ Weight of calculator, 2 x A batteries, flow sensor and 3 m sensor set excl. packaging

6 Display

MULTICAL® 303 has a bright and clear display including 7 or 8 digits depending on the configuration as well as a number of symbols for measuring units, info, inlet and outlet, radio on/off, etc. The display is switched on by pressing the key on the meter's front. The display switches off 8 minutes after the last keystroke. This results in an extension of the meter's battery lifetime. Read more about battery lifetime in paragraph 10.1.

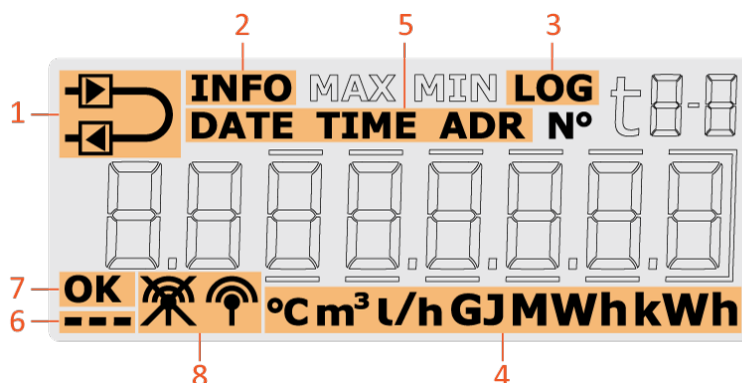

1	The meter is configured as inlet or outlet meter
2	Flashes in case of active info code
3	Historical readings
4	Measuring unit

5	Date, time and address
6	Heart beat indication shows that both meter and display are active
7	“OK” is displayed when a changed value has been saved
8	The meter's radio communication is switched on or off

The meter uses four different display loops. The four loops are intended for four different usage situations:

- “USER loop”**
 The meter's configurable display loop, which is intended for the user. The readings in this loop can be adjusted via the DDD-code, as required. See paragraph 3.2.4 for an overview of possible readings in the meter's “USER loop”. The same paragraph includes examples of DDD-codes.
- “TECH loop”**
 This loop is intended for technicians and is not configurable. The loop displays all the meter's readings. The loop includes readings such as serial number, date, time, config. number, software revision and segment test. See paragraph 6.2 for a complete overview of the readings.
- “SETUP loop”**
 This loop is also intended for the technician. In this loop, the technician can configure the meter via the front key. In general (unless otherwise requested by the customer), the loop is open in transport state. When the first integration has been carried out by the meter, the access to “SETUP loop” is blocked. From now on, it is no longer possible to access “SETUP loop” unless the “SETUP” seal is broken. See paragraph 6.3 for further details on the various parameters that can be configured in “SETUP loop”, and see paragraph 7.8 for details on the meter's transport state.
- “TEST loop”**
 Used by authorized laboratories for reverification of the meter. This loop is not available unless the meter's test seal (verification seal) is broken.

By means of the meter's key, you can choose from and switch between the four display loops. When delivered, the meter is in transport state, which means that “USER loop”, “TECH loop” and “SETUP loop” are available. Depending

MULTICAL® 303

on the country code, the access to “SETUP loop” can be blocked in transport state and is thus not available on delivery. “TEST loop” can only be accessed if the test seal (verification seal) is broken.

Keeping the key activated for 5, 7 and 9 seconds, respectively, you can change between the meter’s display loops. “TECH loop”, “SETUP loop” and “TEST loop” use index numbers as the readings in these display loops are allocated to a specific index number. The index numbers facilitate navigation to the required reading. Index numbers are not used in the configurable “USER loop”. The figure below illustrates how it is possible to navigate in the meter’s display using the key.

MULTICAL® 303 - Display loop

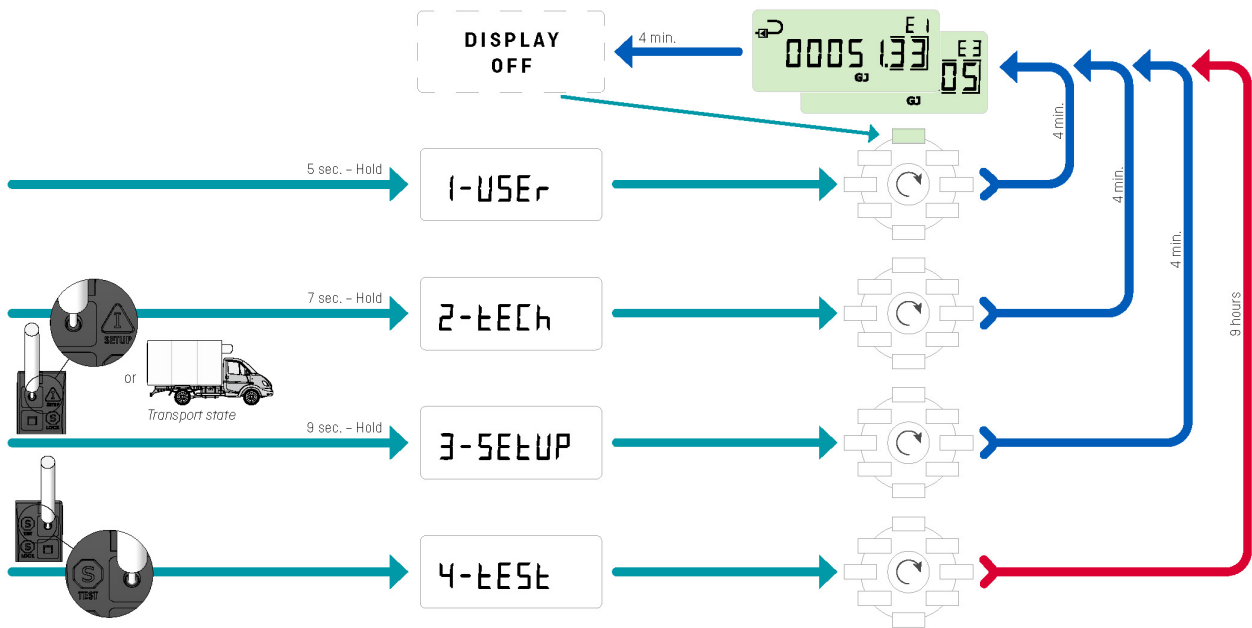

To facilitate the diagnostics work, lines are shown in the display readings (current values) that are influenced by the error and at the same time, counting stops in the registers that are influenced by the error. In case of a disconnected or short-circuited temperature sensor, the corresponding display reading will include lines. No lines are shown for flow measurement in case of the flow sensor error “Wrong flow direction” as this error does not prevent the meter from measuring. If the flow sensor is prevented from measuring, e.g. due to air in the flow sensor, the reading includes lines. The meter registers these errors and sets an info code, which can easily be read from the meter’s display. Read more about the meter's info codes in paragraph 7.6.

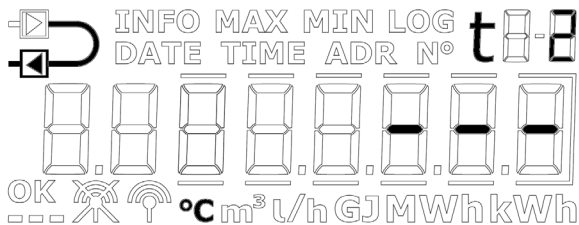

Temperature sensor error t2

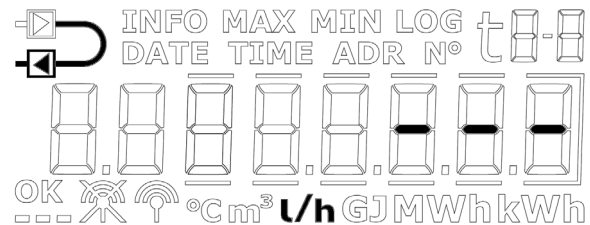

Flow sensor error

	t1 error	t2 error	Flow error
t1 inlet	Display: - - -		
t2 outlet		Display: - - -	
Δt (t1-t2)	Display: - - -	Display: - - -	
Flow, V1			Display: - - -
Power, V1	Display: - - -	Display: - - -	Display: - - -
E1	No counting	No counting	No counting
E3	No counting	No counting	No counting
E8	No counting		No counting
E9		No counting	No counting
V1			No counting

Heart beat and status indication

MULTICAL® 303 uses the three small display segments in the lower left corner of the display to indicate various status scenarios. Each segment will, depending on whether it is static or flashes, provide information about the given functionality in the meter. This is shown in the figure below:

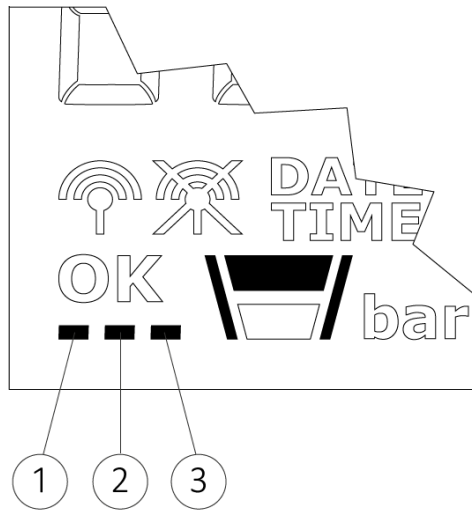

① Heart beat segment

Flashes - This segment always flashes as an indication that both the meter and display are active.

② SETUP and config segment

Constantly lit - The meter’s config log is full, and it is therefore no longer possible to change the configuration.

Flashes - It is possible to access the "SETUP loop". The segment flashes as long as the meter is in transport state or 4 minutes after the calculator top and base have been separated.

Turned off - It is not possible to access the "SETUP loop" or to configure the meter via METERTOOL HCW.

③ Optical interface segment¹

Constantly lit - The meter’s optical interface is deactivated, and optical communication is thus not possible.

Flashes - The optical interface is temporarily active, flashes for 4 minutes after the calculator top and base have been separated. In this period of time, it is possible to activate the optical interface permanently.

Turned off - The optical interface is active, and it is possible to communicate with the meter.

¹ The optical interface can be deactivated and activated via the optical readout head and METERTOOL HCW. See Technical Description for METERTOOL HCW (5512-2097).

Positive/negative signs in heat/cooling applications

The accumulated energy registers, E1 and E3, are both always displayed as positive values. Differential temperature and power are either displayed as positive (heat) or negative (cooling) when reading the values on MULTICAL® 302, 303, 403, 603 and 803.

6.1 “USER loop”



“USER loop” is the meter’s primary loop, which includes the legal and mostly used readings. The loop is intended for the user and is configured according to the user’s requirements via the DDD-code. See paragraph 3.2.4 for further information on “USER loop” and DDD-codes.

Note No display index numbers are used in “USER loop”.



6.2 “TECH loop”



“TECH loop” is intended for the technician who is interested in viewing more readings than the ones available in “USER loop”.

“TECH loop” is not configurable and includes all the meter’s readings. “TECH loop” comprises a number of fixed readings as well as a number of communication readings, which depend on the communication type.

The meter’s “TECH loop” is shown below. A brief activation of the key makes the display reading shift to the next reading, whereas a long activation of the key results in a change to secondary readings. With a subsequent long activation of the key, the display will revert to the primary readings.

				Index number in display	Logging depth in display	Reference numbers in display
1	Heat energy (E1)			2-001		
		1.1	Date of yearly logger	2-001-01	Log 01-02	
		1.2	Data of yearly logger ¹	2-001-02		
		1.3	Date of monthly logger	2-001-03	Log 01-12	
		1.4	Data of monthly logger ¹	2-001-04		
		1.5	E1 High-resolution	2-001-05		
2	Cooling energy (E3)			2-002		
		2.1	Date of yearly logger	2-002-01	Log 01-02	
		2.2	Data of yearly logger ¹	2-002-02		
		2.3	Date of monthly logger	2-002-03	Log 01-12	
		2.4	Data of monthly logger ¹	2-002-04		

MULTICAL® 303

		2.5	E3 High-resolution	2-002-05		
3	Volume (V1)			2-003		
		3.1	Date of yearly logger	2-003-01	Log 01-02	
		3.2	Data of yearly logger ¹	2-003-02		
		3.3	Date of monthly logger	2-003-03	Log 01-12	
		3.4	Data of monthly logger ¹	2-003-04		
		3.5	V1 High-resolution	2-003-05		
4	Hour counter			2-004		
		4.1	Error hour counter	2-004-01		N° 60
5	t1 (Inlet)			2-005		
		5.1	Year-to-date average ²	2-005-01		
		5.2	Month-to-date average ²	2-005-02		
6	t2 (Outlet)			2-006		
		6.1	Year-to-date average ²	2-006-01		
		6.2	Month-to-date average ²	2-006-02		
7	Δt (t1-t2) (Cooling shown by -)			2-007		
		7.1	E8 (m ³ x t1)	2-007-01		
		7.2	E9 (m ³ x t2)	2-007-02		
8	Flow, V1			2-008		
		8.1	Date of max this year ³	2-008-01		
		8.2	Data of max this year ¹	2-008-02		
		8.3	Date of max this month ³	2-008-03		
		8.4	Data of max this month ¹	2-008-04		
		8.5	Date of min. this year ³	2-008-05		
		8.6	Data of min. this year ¹	2-008-06		
		8.7	Date of min. this month ³	2-008-07		
		8.8	Data of min. this month ¹	2-008-08		
9	Thermal power, V1			2-009		
		9.1	Date of max this year ³	2-009-01		
		9.2	Data of max this year ¹	2-009-02		
		9.3	Date of max this month ³	2-009-03		
		9.4	Data of max this month ¹	2-009-04		
		9.5	Date of min. this year ³	2-009-05		
		9.6	Data of min. this year ¹	2-009-06		
		9.7	Date of min. this month ³	2-009-07		
		9.8	Data of min. this month ¹	2-009-08		

10	Info code			2-010		
		10.1	Info event counter	2-010-01		
		10.2	Date of yearly logger	2-010-02	Log 01-50	
		10.3	Data of yearly logger ¹	2-010-03		
11	Customer number			2-011		N° 1
		11.1	Customer number	2-011-01		N° 2
		11.2	Date	2-011-02		
		11.3	Hour	2-011-03	Log 01-02	
		11.4	Yearly target date 1	2-011-04		
		11.5	Monthly target date 1	2-011-05	Log 01-12	
		11.6	Yearly target date 2	2-011-06		
		11.7	Monthly target date 2	2-011-07		
		11.8	Serial number	2-011-08		N° 3
		11.9	Type number (dynamic)	2-011-09		N° 21
		11.10	Config 1 (ABCCDDDD)	2-011-10		N° 5
		11.11	Config 2 (LRRTVVVV)	2-011-11		N° 6
		11.12	Software revision	2-011-12		N° 10
		11.13	Software checksum	2-011-13		N° 11
		11.14	MID-004 type-appr. cert. revision	2-011-14		N° 12
		11.15	BEK-1178 type-appr. cert. revision	2-011-15		N° 13
		11.16	National type-appr. cert. revision	2-011-16		N° 14
		11.17	Averaging period of min./max P and Q	2-011-17		
		11.18	θ_{nc}	2-011-18		
		11.19	Temperature sensor offset	2-011-19		
		11.20	Temperature cut-off ($\Delta\theta$)	2-011-20		
		11.21	Segment test	2-011-21		
101	Config. communication (XXX-YY-ZZZ)			2-101		N° 31
		101.1	Primary M-Bus address	2-101-01		N° 34
		101.2	M-Bus secondary ID	2-101-02		N° 35
		101.3	M-Bus enhanced secondary ID	2-101-03		N° 36

¹ Depending on the selected depth of yearly and monthly logs in the programmable data logger, these display readings can include empty readings.

² The average is volume-based.

MULTICAL® 303

³ Only the date of min./max is displayed in the format 20xx.xx.xx. Through serial reading, it is also possible to obtain the time (hh.mm).

6.3 “SETUP loop”



In this loop, the technician can configure the meter via the front key. This enables the technician to configure the meter both before installation and after commissioning of the meter. Configuration of the meter after commissioning requires that the “SETUP” seal is broken and that the contact points underneath are short-circuited.

Please note that it is only possible to configure the meter 25 times via “SETUP loop”.
After 25 times, the meter is locked against further configuration, and the meter must be totally reset and reverified to regain access to “SETUP loop”.

How to enter “SETUP loop”

1. In general (unless otherwise requested by the customer), “SETUP loop” is available when the meter is in transport state. The meter leaves transport state at the first integration or if “SETUP loop” is ended via the menu item “EndSetup”. A total reset of the meter is the only way to revert to transport state.
2. When the meter is in operation, i.e. the meter has left transport state, “SETUP loop” can be accessed by breaking the meter’s “SETUP” seal, i.e. breaking the seal on the rear side of the calculator and short-circuit the two contact points on the PCB underneath.

How to exit “SETUP loop”

You can exit “SETUP loop” in three ways. All three ways can be used both in transport state and after commissioning of the meter.







1. Keep the key activated and navigate to the meter’s other loops.
2. After 4 minutes, the meter will time out and revert to the first reading in “USER loop”.
3. Navigate to the menu item “EndSetup” in “SETUP loop” and keep the key activated for 5 seconds.

Note This locks the access to “SETUP loop” and thereby, the meter is locked against further configuration. Subsequent reconfiguration of the meter requires that you break the “SETUP” seal.

IMPORTANT: “EndSetup” is an important function when the meter is in transport state, but when the meter is in operation, “EndSetup” is just one of three ways to exit “SETUP loop”.

As it appears from the table below, the purpose of the menu item “EndSetup” is to enable the technician to lock the access to “SETUP loop” in transport state and thus lock the meter against further configuration. This function is, for example, relevant to a technician who knows that a meter is to be mounted in the installation for some time before the first integration will be carried out and wants to lock the access to “SETUP loop” immediately after the installation to make sure that no further configuration of the meter is possible.

It also appears from the table below that no matter how you exit “SETUP loop” when the meter is in operation, the “SETUP” seal must be broken again if the technician wants to regain access to “SETUP loop”.

	Transport state	In operation
1. Key	 Access to “SETUP loop”	 Access to “SETUP loop” locked
2. Time out	 Access to “SETUP loop”	 Access to “SETUP loop” locked
3. EndSetup	 Access to “SETUP loop” locked	 Access to “SETUP loop” locked

6.3.1 Changing parameters in “SETUP loop”

The user can navigate to “SETUP loop” from “USER loop” by keeping the key activated for 9 seconds until the text “3-SETUP” appears in the display. When the key is released, the “SETUP loop” can be accessed and after this, the key is used for navigating to the required parameter by activating the key at brief intervals. “SETUP loop” does not include secondary readings and therefore, the index number always consists of 4 digits. See table with “SETUP” parameters. If the meter has been commissioned, “SETUP loop” can be accessed by breaking the “SETUP” seal on the rear side of the calculator.

To access the individual readings in “SETUP loop” to change a parameter, the key is activated until the text “SETUP” flashes in the display. Then the key is released. Then the part of the parameter that can be changed flashes, and you can shift to the next part of the parameter by activating the key until the next part flashes after which this can be changed through brief activations of the key, and so on. The setup of a parameter is ended by activating the key and letting the meter shift between all parts of the parameter until “OK” appears in the display. Then the key is released and the meter reverts to the parameter list in “SETUP loop”.

Note A change of the B-code and/or CCC-code is not saved until you leave “SETUP loop”.

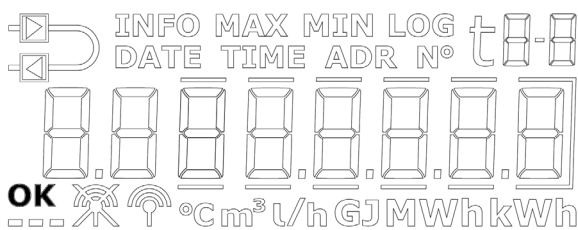

MULTICAL® 303

The table below shows the parameters that can be changed via “SETUP loop” and then, each parameter is explained in more detail.

 Front key		Index number in display
1	Customer number (N° 1)	3-001
2	Customer number (N° 2)	3-002
3	Date	3-003
4	Time ¹	3-004
5	Yearly target date 1 (MM.DD)	3-005
6	Monthly target date 1 (DD)	3-006
7	Flow sensor position: Inlet or Outlet (A-code)	3-007
8	Measuring unit and resolution (B- and CCC-code) (B- and CCC-codes are configured as e.g. “0.001 MWh” and “0.01 m ³ ”)	3-008
9	Primary address for M-Bus (N° 34)	3-009
10	Averaging period of min./max P and Q	3-010
11	Heat/cooling shift (θ_{hc}) ² (Only active if meter type 6 is selected)	3-011
12	Temperature sensor offset (t_{ro}) ³	3-012
13	Radio On/Pause/Stop	3-013
14	EndSetup	3-014

¹ In addition to adjusting the clock via “SETUP loop”, the clock and the date can also be changed via MeterToolX/HCW and data communication.

² θ_{hc} can only be changed in meters configured as meter type 6. In this meter type, users can both change θ_{hc} and disable the function. If users attempt to access this menu in meters configured as other meter types, the message “Off” is displayed.

³ This function can have been disabled via the selected country code.

1. + 2. Customer number

The customer number is a 16-digit figure distributed on two 8 digit menu items. The complete customer number can be adjusted via the two menu items in "SETUP loop".

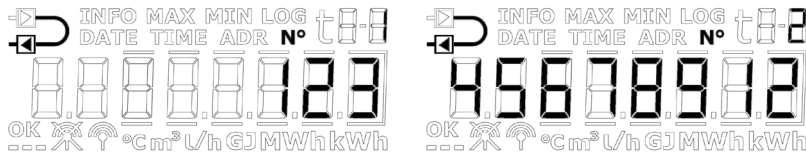

3. Date

The meter's date can be adjusted in "SETUP loop". It is recommended to verify that the date was adjusted correctly, especially if the time was adjusted too.



4. Time

The meter's time can be adjusted in "SETUP loop". It is recommended to verify that the time was adjusted correctly, especially if the date was adjusted too.



5. Yearly target date 1

The meter's yearly target date 1 can be adjusted in "SETUP loop". In MULTICAL® 303, yearly target date 2 can be activated. This function is switched off by default, i.e. set to 00.00. If yearly target date 2 is active in a meter, it is recommended that both yearly target dates are adjusted via MeterToolX/HCW to ensure that they are correctly set with respect to each other. Please note that activation of yearly target date 2 influences the depth of the yearly log as the meter now makes two yearly loggings.

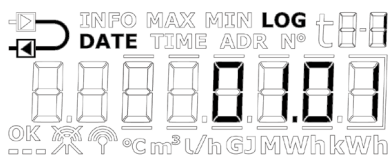

6. Monthly target date 1

The meter's monthly target date 1 can be adjusted in "SETUP loop". In MULTICAL® 303, monthly target date 2 can be activated. This function is switched off by default, i.e. set to 00. If monthly target date 2 is active in a meter, it is recommended that both monthly target dates are adjusted via MeterToolX/HCW to ensure that they are correctly set with respect to each other. Please note that activation of monthly target date 2 influences the depth of the monthly log as the meter now makes two monthly loggings.

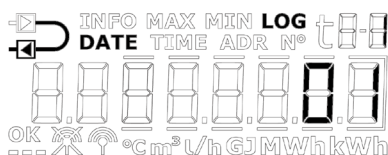

7. Flow sensor position: Inlet or Outlet (A-code)

The installation position of the flow sensor can be adjusted in “SETUP loop”. This means that the meter can be changed from being an outlet meter to being an inlet meter and vice versa. A symbol in the top left corner of the meter’s display shows whether the meter is configured as an inlet or an outlet meter.

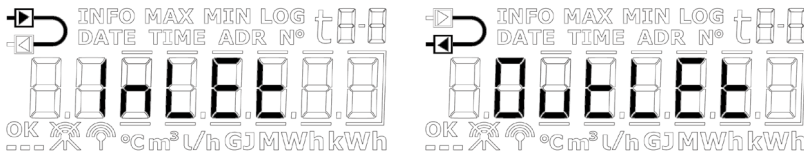

7.1 Temperature sensor placement

The above choice of “Inlet”/“Outlet” only includes the placement of the flow sensor. Always ensure that the temperature sensor “t1” is placed at inlet and that the temperature sensor “t2” is placed at outlet.

When changing from, for example, “Inlet” to “Outlet”, you must thus ensure that the temperature sensors are relocated accordingly.

8. Measuring unit and resolution (B- and CCC-code)

The meter’s measuring unit (B-code) and resolution (CCC-code) can be adjusted in “SETUP loop”. It is thus possible to change the meter’s energy readings to be displayed in kWh, MWh or GJ as well as change the resolutions of both energy reading and volume reading.

Note A change of the B-code and/or the CCC-code is not saved until you leave “SETUP loop”.

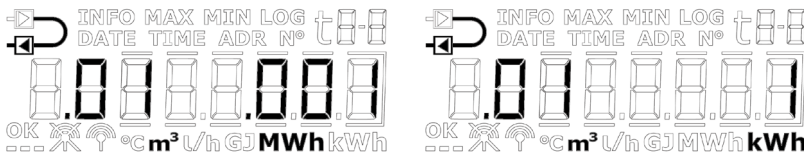

You can choose between an exactly defined number of combinations of B- and CCC-codes. These combinations are entered in a table and programmed into the meter during factory configuration. This table is determined on the basis of the selected flow sensor and the selected nominal flow (q_p). Below is an example of the table at $q_p = 1,5 \text{ m}^3/\text{h}$.

$q_p = 1,5 \text{ m}^3/\text{h}$		Number of decimals on display						
B-code	CCC-code	GJ	kWh	MWh	m^3	l/h	m^3/h	kW
2	419	2	-	-	2	0	-	1
3	419	-	0	-	2	0	-	1
4	419	-	-	3	2	0	-	1
2	407	3	-	-	3	0	-	1
3	407	-	1	-	3	0	-	1
2	455	3	-	-	2	0	-	1
3	455	-	1	-	2	0	-	1

9. M-Bus primary address

The meter's primary M-Bus address can be adjusted in "SETUP loop". The address can be selected in the interval 0...250.

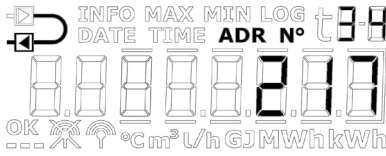

10. Averaging period of min./max P and Q

The averaging period used in the calculation of minimum and maximum values of power (P) and flow (Q) can be adjusted. The averaging period is stated in minutes. Read more about the averaging period of min./max of P and Q in paragraph 7.4.

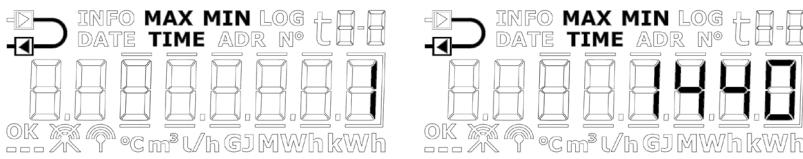

11. Heat/cooling shift (θ_{hc})

The limit (θ_{hc}) for heat/cooling shift can be adjusted in "SETUP loop", however only in meters ordered as meter type 6 (heat/cooling meter). The value can be set in the interval 2...180,00 °C as well as to 250,00 °C if the user wants to disable the function. The function can be enabled again by setting the limit to a value in the valid area of 2...180 °C. Heat/cooling shift is permanently disabled in other meter types, and "Off" will thus be displayed for this reading in all other meter types than 6. Read more about heat/cooling shift in paragraph 7.3.

Meter type: 2, 3, 4, 5	Meter type: 6
<p>The frames around "Off" will light up as long as the front key remains activated.</p>	<p>The first digit flashes and each digit can now be set to a value between 0 and 9.</p> <p>If you choose a value outside the valid interval (2...180,00 °C), the value is automatically adjusted to 250,00 °C, which indicates that the function is disabled.</p>

MULTICAL® 303

12. Temperature sensor offset (t_{r0})

The temperature sensor offset (t_{r0}) can be adjusted in “SETUP loop”. Depending on the meter’s configuration, this function can be disabled and the menu item will in that case display “Off”.

Offset can be adjusted in the interval -0,99...0,99 K. Pressing the front key, the 0 and the sign start flashing and it is now possible to toggle between – and +, indicated in the display by the fact that the minus sign flashes and switches off, respectively. Pressing the front key, the meter shifts focus to the first decimal, i.e. it is not possible to change the value of the first digit as the valid interval is -0,99...0,99 K. Both the first and the second decimal can be set to a value between 0 and 9. Read more about temperature sensor offset in paragraph 7.2.

Please note that the required offset adjustment must be entered, not the error of the temperature sensor set.

If the selected temperature sensor set contributes with the error -0,20 K, the meter’s offset must be set to 0,20 K.

Furthermore, note that MULTICAL® 303 is always delivered with offset adjusted for the mounted temperature sensor set if this function is active on the country code in question. Exchanging the temperature sensor set on MULTICAL® 303 requires breaking the legal seal which is why an exchange may only be performed by an authorised laboratory that can add new sealing subsequently. Read more about sealing levels in paragraph 4.9.

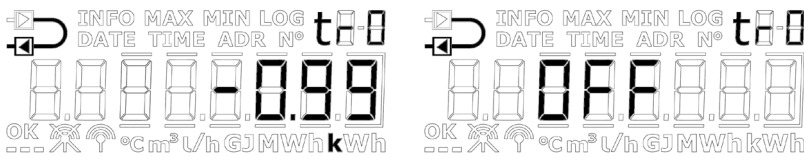

13. Radio On/Pause/Stop

The meter's radio/wireless communication can be adjusted to being switched on or switched off. The meter automatically switches on the radio when the meter leaves transport state because it has carried out its first integration. The Radio On/Pause/Stop function in "SETUP loop" is used for switching on the radio in transport state without the meter having made an integration as well as for switching off the radio when the meter is dismantled after having been in operation, for example because it is to be sent by airfreight (RF Pause) or if the radio is to be switched off permanently (RF Stop). The meter's present condition is indicated by two symbols in the bottom left corner of the display. There are various ways to switch on the radio in MULTICAL® 303. It is possible to automatically switch on the radio communication after a predefined period of time¹. The timer starts when the meter has been produced in the factory. In addition, the radio communication can be switched off permanently.

RF Stop

When MULTICAL® 303 leaves the factory, the radio is always switched off due to transport restrictions². If it is required that the radio is switched off permanently, the meter can be configured for Radio Stop via "SETUP loop" or MeterToolX/HCW upon delivery.

RF On and RF Pause

There are three ways of switching on the radio and starting to send data:

1. Consumption: Consumption (water flow) is registered by the meter and switches on the radio.
2. Automatically via timer: The hour counter reaches the predefined time, and the meter switches on the radio.
3. "SETUP loop": In "SETUP loop" (or via MeterToolX/HCW), the technician manually switches on the radio.

When MULTICAL® 303 has been installed, the meter can have one of the following three settings: RF Stop, RF Pause and RF On. All three settings are described and shown below.



The radio is switched off permanently



The radio is switched off temporarily until it is switched on manually, the timer is activated or a consumption is registered



Radio is switched on

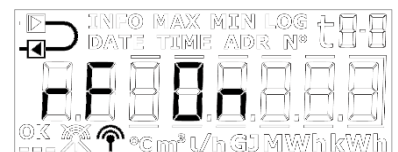

IMPORTANT

- If the meter is in “TEST” mode, the meter will not be switched on by the activation of the timer or by a registration of consumption.
- A total reset of the meter will reset the meter to RF Pause, which is the setting that all meters are delivered with.
- The installation request cannot be used when the meter's radio is switched off permanently (RF Stop).

¹ If this function is selected via the country code.

² At delivery from factory, all meters are set to RF Pause.

Note The above only applies to MULTICAL® 303 delivered with wM-Bus. For meters with wired M-Bus, the display symbols in the lower left corner will be permanently switched off and the parameter in “SETUP loop” will show “no RF”.

14. EndSetup

The menu item “EndSetup” enables the technician to lock the access to “SETUP loop” in transport state and thus lock the meter against further configuration. To do so, the front key must be activated for five seconds in the menu item 3-014 in “SETUP loop”. During the five seconds, the frames around the reading “EndSetup” will be shown in the meter’s display. This action can be undone by releasing the front key before the whole frame has become illuminated, i.e. before the five seconds have passed.

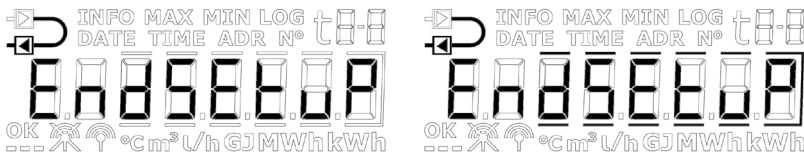

“EndSetup” is an important function when the meter is in transport state, but when the meter is in operation, “EndSetup” is just one of three ways to exit “SETUP loop”. See paragraph 6.3 above.

6.4 “TEST loop”





“TEST loop” is used by authorized laboratories for, among other things, reverification of the meter.

Before the meter can enter “TEST loop” and thus “TEST” mode, the verification seal marked “TEST” on the meter must be carefully broken with a screwdriver and the contact points behind the seal be short-circuited with the short-circuit pen type (6699-278).

It is recommended to complete your work in “TEST loop” before initiating the reconfiguration via “SETUP loop” or MeterToolX/HCW as every reconfiguration is logged (only 25 reconfigurations are permitted).

The meter leaves “TEST” mode and returns to the first reading in “USER loop” after 9 hours (time-out), or if the user keeps the key activated for 5 seconds and releases it again when the display shows the text “1-USER”.

The meter’s “TEST loop” is shown below. A brief activation of the key makes the display reading shift to the next reading, whereas a long activation of the key results in a change to secondary readings. With a subsequent long activation of the key, the display reverts to the primary readings.

 Primary readings	 Secondary readings	Index number in display
---	---	-------------------------

1.0	High-resolution heat energy ¹			4-001
		1.1	Heat energy (E1)	4-001-01
2.0	High-resolution cooling energy ¹			4-002
		2.1	Cooling energy (E3)	4-002-01
3.0	High-resolution volume ¹			4-003
		3.1	Volume	4-003-01
4.0	t1 (Inlet)			4-004
5.0	t2 (Outlet)			4-005
6.0	Flow			4-006

¹ The resolutions of the high-resolution registers are 1 Wh and 10 ml, respectively, for all flow sizes. The registers can only be reset by a total reset of the meter.

7 Calculator functions



7.1 Application types and energy calculations

MULTICAL® 303 operates with four different energy formulas, E1, E3, E8, E9, which are all calculated in parallel at every integration no matter how the meter is configured. E8 and E9 are used as a basis for the calculation of average temperatures of inlet and outlet, whereas E1 and E3 are used for heat and cooling measurement, respectively.

7.1.1 Heat/cooling energy registers E1 and E3

The energy types E1 and E3 are described by application examples below.

Symbols used in application figures

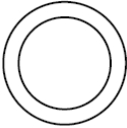
†	Temperature sensor		Stop valve		Flow sensor
	Calculator		Consumer, e.g. heaters		

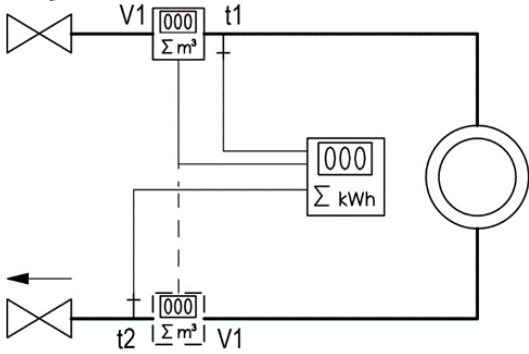
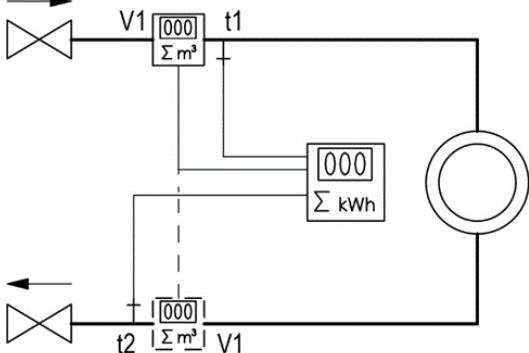
 <p style="text-align: center;">303-Wxx2/4</p>	<p>Application A</p> <p>Closed heat system with 1 flow sensor</p> <p>Heat energy: $E1 = V1(t1-t2)k_{t1:Inlet \text{ or } t2:Outlet}$</p> <p>Flow sensor V1 is mounted in inlet or outlet as selected during config.</p> <p>(Heat meter with MID marking and Pt500 sensor inputs)</p>
 <p style="text-align: center;">303-Cxx5</p>	<p>Application B</p> <p>Closed cooling system with 1 flow sensor</p> <p>Cooling energy: $E3 = V1(t2-t1)k_{t1:Inlet \text{ or } t2:Outlet}$</p> <p>Flow sensor V1 is mounted in inlet or outlet as selected during config.</p> <p>(Cooling meter with condensation protection and Pt500 sensor inputs)</p>

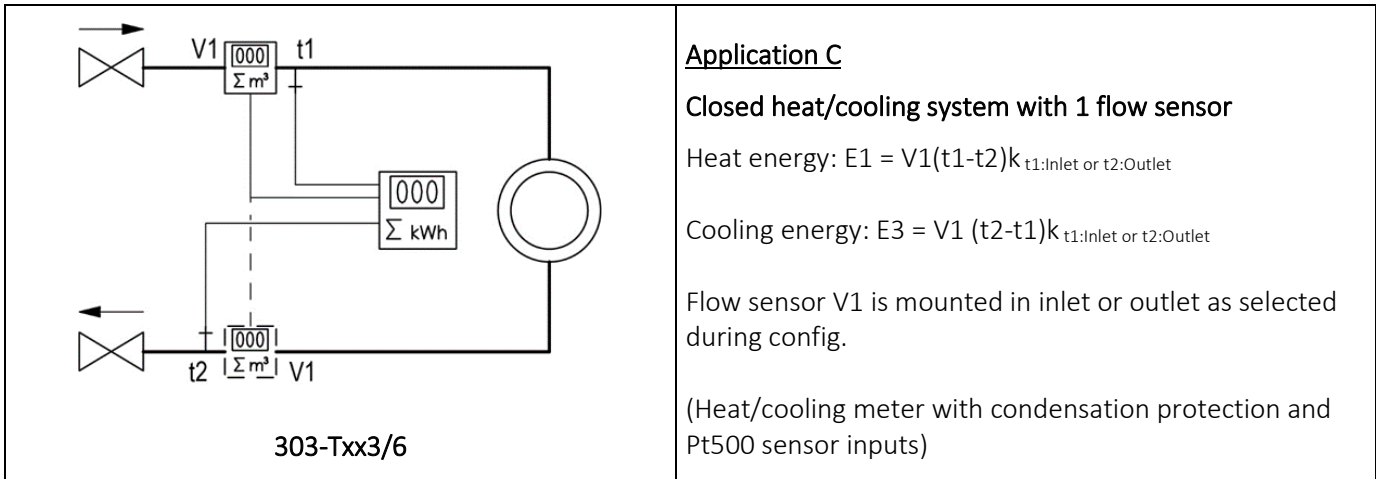

Application C

Closed heat/cooling system with 1 flow sensor

Heat energy: $E1 = V1(t1-t2)k_{t1:Inlet \text{ or } t2:Outlet}$

Cooling energy: $E3 = V1 (t2-t1)k_{t1:Inlet \text{ or } t2:Outlet}$

Flow sensor V1 is mounted in inlet or outlet as selected during config.

(Heat/cooling meter with condensation protection and Pt500 sensor inputs)

7.1.2 Energy registers E8 and E9

E8 and E9 are used as a basis for calculating the volume-based average temperatures of inlet and outlet, respectively. With every volume count (every 0,01 m³ for q_p 1,5 m³/h with CCC=419), the registers are accumulated by the product of m³ x °C, which makes E8 and E9 a suitable basis for calculating the volume-based average temperatures.

E8 and E9 can be used for average calculation during any period of time as long as the volume register is read at the same time as E8 and E9.

Volume resolution	Resolution of E8 and E9
0000,001 m ³	m ³ x °C x 10
00000,01 m ³	m ³ x °C
000000,1 m ³	m ³ x °C x 0,1
0000001 m ³	m ³ x °C x 0,01

Resolution of E8 and E9

E8 and E9 depend on the resolution of the volume V1 (m³) that is fixed by the CCC-code. This dependency means that a factor is used in connection with the calculation of E8 and E9. This also means that the same factor must be used in connection with the calculation of the average temperature.

E8 and E9 can be used for calculating the average temperature in inlet and outlet in any periods of time if only:

- 1) The volume register is read at the same time as E8 and E9,
- 2) the relevant resolution factor is included in the calculation,
- 3) the requirement for a minimum flow (volume) is complied with.

E8 = m³ x t1, E8 is increased by the product of m³ x t1

E9 = m³ x t2, E9 is increased by the product of m³ x t2



Example 1: E8 and E9 for a heat installation that within a year has used 250,00 m³ district heating water with average temperatures of 95 °C in inlet and 45 °C in outlet. The meter has a volume resolution of 00000,01 m³ and thus, the formula m³ x °C is used with the following result: E8 = 23750 and E9 = 11250.

Example 2: The average temperatures are to be measured together with the yearly reading. Therefore, E8 and E9 are included in the yearly reading. The meter used in this calculation example is a q_p 1,5 m³/h with CCC-code 419 (volume resolution with 2 decimal/000000,1 m³).

Reading date	Volume	E8	Temp. average for inlet	E9	Temp. average for outlet
2021.01.01	307,34 m ³	14964		8814	
2020.01.01	173,29 m ³	8470		4884	
Yearly consumption	134,05 m ³ (307,34 – 173,29 m ³)	6494 (14964 - 8470)	6494 / 134,05 = 48,44 °C	3930 (8814 – 4884)	3930 / 134,05 = 29,32 °C

Table 4

7.1.3 Energy calculations

MULTICAL® 303 calculates energy on the basis of the formula stated in EN 1434-1, which uses the international temperature scale issued in 1990 (ITS-90) and the pressure definition of 16 bar.

In a simplified form, the energy calculation can be expressed as: Energy = V x ΔΘ x k. The calculator always calculates energy in [Wh] and then converts the value to the selected measuring unit.

E [Wh] =	V x ΔΘ x k x 1.000
E [kWh] =	E [Wh] / 1.000
E [MWh] =	E [Wh] / 1.000.000
E [GJ] =	E [Wh] / 277.800

V is the added (or simulated) water volume in m³

ΔΘ is the measured temp. difference: Heat energy (E1) ΔΘ = inlet temperature less outlet temperature
Cooling energy (E3) ΔΘ = outlet temperature less inlet temperature

Both in the display and during data reading, each energy type is uniquely defined, e.g.

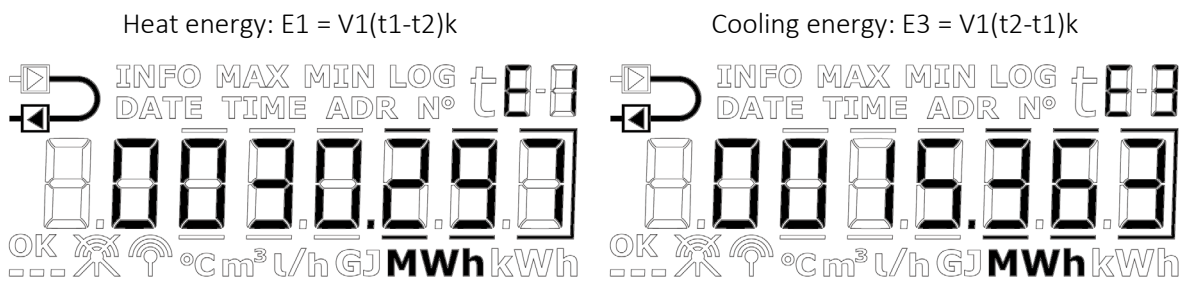

k is the heat coefficient of water, calculated according to the formula of EN 1434 and OIML R75-1:2002

Kamstrup A/S can supply an energy calculator for check measurement:

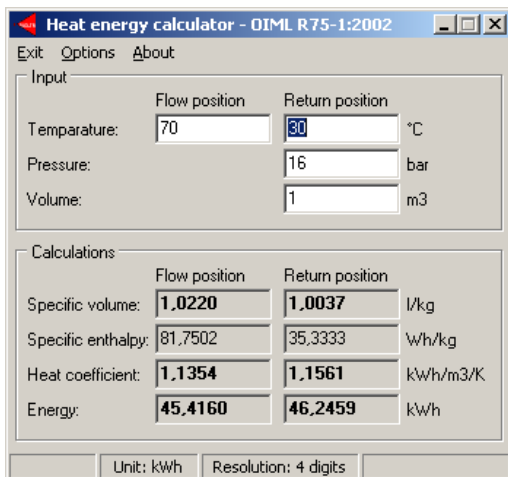

MULTICAL® 303

Kamstrup A/S can supply an energy calculator for check measurement:

		Calculation	Condition
Heat energy (E1)	Inlet	$E1 = m^3 \times (t1-t2)k_{t1}$	$t1 > t2$ If $t1 = t2$, then $E1/E3 = 0$ $\theta_{t1} > \theta_{hc}$ (meter type 6)
	Outlet	$E1 = m^3 \times (t1 - t2)k_{t2}$	$t1 > t2$ If $t1 = t2$, then $E1 = 0$ $\theta_{t1} > \theta_{hc}$ (meter type 6)
Cooling energy (E3)	Inlet	$E3 = m^3 \times (t2 - t1)k_{t1}$	$t1 < t2$ $\theta_{t1} < \theta_{hc}$ (meter type 6)
	Outlet	$E3 = m^3 \times (t2 - t1)k_{t2}$	$t1 < t2$ $\theta_{t1} < \theta_{hc}$ (meter type 6)
Supplied/returned energy (E8, E9)		$E8 = m^3 \times t1$ $E9 = m^3 \times t2$	

In case of failing temperature sensor or flow measurements, the counting stops in the registers, which are influenced by the error. Furthermore, the displayed reading in question will include lines.

	t1 error	t2 error	Flow error
t1 inlet	Display: - - -		
t2 outlet		Display: - - -	
Δt (t1-t2)	Display: - - -	Display: - - -	
Flow, V1			Display: - - -
Power, V1	Display: - - -	Display: - - -	Display: - - -
E1	No counting	No counting	No counting
E3	No counting	No counting	No counting
E8	No counting		No counting
E9		No counting	No counting
V1			No counting

7.2 Offset adjustment of temperature sensor measurement

MULTICAL® 303 is available with possible offset adjustment of the temperature sensor measurement, thus increasing the accuracy of the absolute temperature measurement. This is especially relevant in the installation scenario in which the meter is to be used for tariff billing based on absolute temperatures. In that case, it is an EN1434 requirement that the accuracy of the meter's absolute temperature reading must be within $\pm 1,0$ K. Offset adjustment is extremely relevant in district cooling installations too. In district cooling installations, the customer often has a right to a maximum inlet temperature. Absolute temperature measurement with undesirable inaccuracy can cause the supplier to supply water with a lower inlet temperature than promised, resulting in unnecessary extra costs for the supplier.

Depending on the meter's configuration, offset adjustment can be programmed into the meter from the factory. Offset can also be adjusted after delivery via the meter's "SETUP loop" (see paragraph 6.3) or via MeterToolX/HCW. See the technical description for MeterTool HCW, 5512-2097.

Note Depending on the meter's configuration, the offset adjustment can be disabled and the menu item in "SETUP loop" will in that case display "Off".

If the temperature sensor set of a meter with offset adjustment is replaced, it is recommended that the offset is corrected to match the newly connected sensor set. Alternatively, offset should be adjusted to 0,00 K, which means that the function is switched off and does not contribute to an undesirable increase of the error of the absolute temperature measurements.

Temperature sensor offset (t_{0}) can be adjusted in the interval -0,99...0,99 K according to the meter's approval.

Please note that the required offset adjustment must be entered, not the error of the temperature sensor set.
If the selected temperature sensor set contributes with an error of -0,20 K,
the meter's offset must be set to 0,20 K.

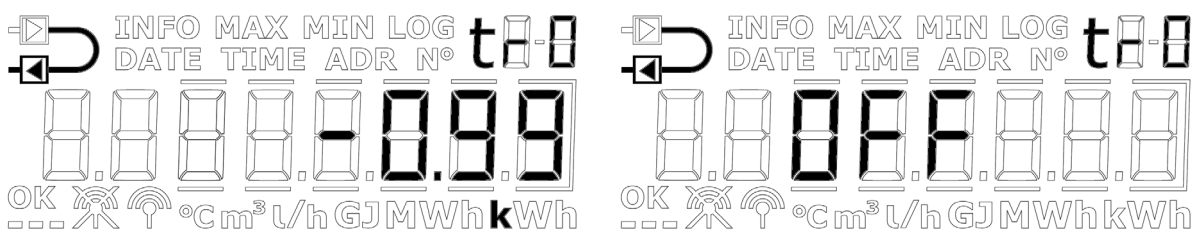

7.3 Bifunctional heat/cooling metering

MULTICAL® 303 is available as heat meter (meter type 2), cooling meter (meter type 5) or bifunctional heat/cooling meter (meter type 3 and 6).

Meter type

Heat meter (MID module B+D)		2
Heat/cooling meter (MID module B+D & TS27.02+DK268)*	$\Theta_{hc} = \text{OFF}$	3
Cooling meter (TS27.02+DK268)		5
Heat/cooling meter (MID module B+D & TS27.02+DK268)*	$\Theta_{hc} = \text{ON}$	6
Country code (language on label, etc.)		XX

*In some countries bi-functional meters type 3 and 6 are only allowed to be assigned with the MID marking, due to national law.

If MULTICAL® 303 has been delivered as a heat/cooling meter (meter type 3 and 6), heat energy (E1) is measured at a positive differential temperature ($t_1 > t_2$), whereas cooling energy (E3) is measured at a negative differential temperature ($t_1 < t_2$). Inlet temperature sensor is marked with “t1” and mounted in the inlet, whereas outlet temperature sensor is marked with “t2” and mounted in the outlet.

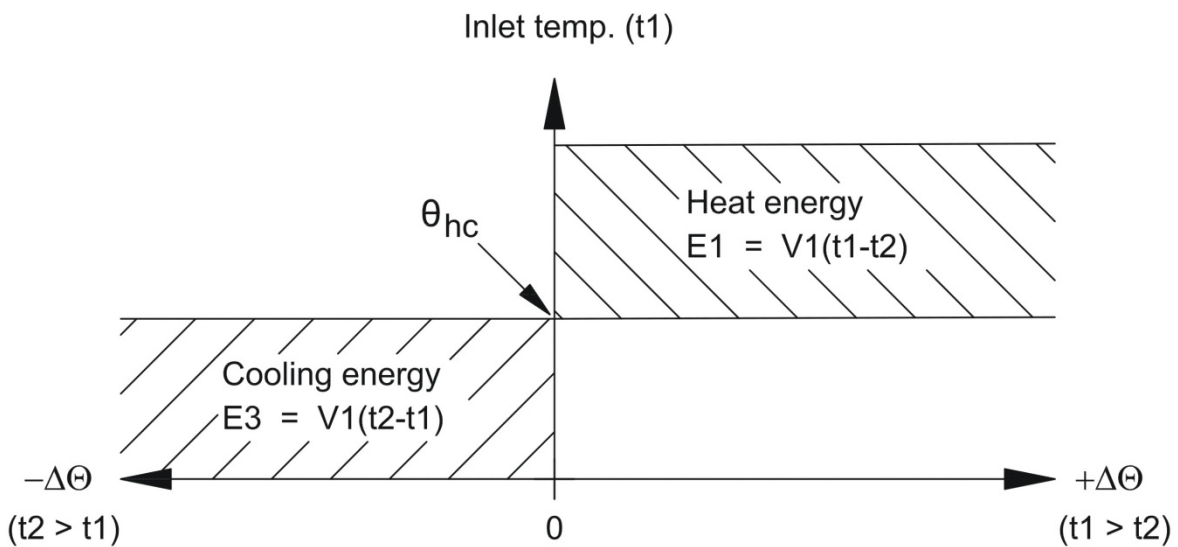

Θ_{hc} acts as a limit value for the measurement of heat/cooling energy. With Θ_{hc} enabled, heat energy is only measured when t_1 is greater than or equal to Θ_{hc} . Likewise, cooling energy is only measured if the inlet temperature t_1 is lower than Θ_{hc} .

In heat/cooling meters, the limit value Θ_{hc} should be set to the highest temperature measured in the inlet in connection with cooling, e.g. 25 °C. If the meter is to be used for billing, Θ_{hc} is a legal value and this appears from the display.

Configuration of the function Θ_{hc} is only possible in meter type 6. Configuration is possible in the interval 0,01..180,00 °C. To disable Θ_{hc} , this value must be configured to 250,00 °C. In other meter types than meter type 6, Θ_{hc} is permanently “OFF” in the configuration. Θ_{hc} is configured via “SETUP loop” or MeterToolX/HCW. See paragraph 6.3 and the technical description of MeterTool HVW, 5512-2097 for further information.

Note There is no hysteresis in connection with shift between heat and cooling energy measurement ($\Delta\Theta_{hc} = 0,00 \text{ K}$).

7.4 Min./max calculations of power (P) and flow (Q)

MULTICAL® 303 registers minimum and maximum flow and power on both monthly and yearly basis. The registrations can be read in “TECH loop” via the meter’s display or via data communication. Furthermore, the current minimum and maximum registration for the present year and month can be displayed in “USER loop”, depending on the selected DDD-code. Read more about the DDD-code in paragraph 3.2.4. In addition, historical data, i.e. minimum and maximum values registered for the previous year and months, can be displayed via LogView HCW or serial communication, provided that these values have been selected in the logger profile via the RR-code. Read more in paragraph 3.2.6.

The current minimum and maximum registrations for the present year and month are displayed together with the date of when the measured minimum or maximum value appeared in the format 20YY.MM.DD. Through serial reading, the time (hh.mm.ss) can be included too. Below, you can get the complete overview of the registers in the display.

Note Historical readings (logging values) are not part of the display readings in MULTICAL® 303. These can only be displayed in LogView HCW or via serial communication.

Flow (V1)	“TECH loop”	
	2-008-01	Date of max this year
	2-008-02	Data of max this year
	2-008-03	Date of max this month
	2-008-04	Data of max this month
	2-008-05	Date of min. this year
	2-008-06	Data of min. this year
	2-008-07	Date of min. this month
2-008-08	Data of min. this month	
Thermal power (V1)	“TECH loop”	
	2-009-01	Date of max this year
	2-009-02	Data of max this year
	2-009-03	Date of max this month
	2-009-04	Data of max this month
	2-009-05	Date of min. this year
	2-009-06	Data of min. this year
	2-009-07	Date of min. this month
2-009-08	Data of min. this month	

Below, examples of the display readings of the date and data readings are shown. The frames around the date indicate whether the date is connected to yearly or monthly data. In data readings of yearly data, the last two digits of the year are marked in frames, whereas the two digits for month are marked for monthly data. Furthermore, the symbols “MIN” and “MAX” are shown to indicate whether the values are minimum or maximum values.

Examples of yearly date and data (max values) for flow



Examples of monthly date and data (min. values) for power

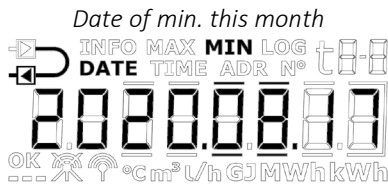

All minimum and maximum values are calculated as the average of a number of current flow or power measurements after each averaging period, the latest value is compared to previous values, and the new value is saved as maximum or minimum if it exceeds the previous maximum value or is lower than the previous minimum value. The averaging period used for all calculations can be selected in the interval 1...1440 minutes in leaps of one minute (1440 min. = 1 day). The averaging period and the target dates are stated in the order. Read more about order data in paragraph 3.3. If not otherwise stated in the order, the default averaging period of 60 minutes is used. This value can later be changed via "SETUP loop" or via MeterToolX/HCW.

Please note the following:

- In the display, the date is shown in the format 20YY.MM.DD, but by serial reading, the time can be stated too and the format then becomes YY.MM.DD, hh.mm.ss.
- The averaging period starts the moment the meter is powered, i.e. when the battery is mounted in the meter. Therefore, the averaging period is not necessarily synchronous with the change of day. Due to this fact, the min./max calculation is immune to the clock setting as the interval is kept intact at, for example, 60 or 1440 minutes.

7.5 Temperature measurement

Inlet and outlet temperatures are measured by means of an accurately matched Pt500 sensor set. During each temperature measurement, MULTICAL® 303 sends measuring current through each temperature sensor. The current is approx. 0,5 mA for Pt500. Two measurements are carried out to suppress possible 50 Hz (or 60 Hz) low-frequency noise picked up via the sensor cables. Furthermore, on a continuous basis, measurements are made by internal reference resistors to ensure optimum measuring stability.

The display presents the inlet and outlet temperatures in the range 0,00 °C to 185,00 °C. The temperature difference is presented in the range 0,01 K to 185,00 K.

By default, the meter has no cut-off for low temperature and thus measures down to 0,01 °C and 0,01 K. If desired, when ordering the meter, a country code can be selected that is programmed with cut-off for temperature difference ($\Delta\theta$) in the area 0,01...2,50 K. It is not possible to program this with METERTOOL. If the meter is programmed with a cut-off of 2,50 K, it will not calculate energy and volume at a temperature difference below 2,50 K.

Note Cut-off for the temperature difference should be distinguished from θ_{nc} , which functions as a limit value of the heat/cooling energy measurement. See paragraph 7.3.

Inlet or outlet temperatures below 0,00 °C and above 185,00 °C are indicated as lines in the display, but serial reading includes 0,00 °C and 185,00 °C, respectively. If one or both temperature sensors are outside the measuring range, the info code is set as shown in the next paragraph.

At negative temperature difference (inlet < outlet), the temperature difference is displayed with a negative sign and cooling energy is calculated. It depends on the selected DDD-code whether the cooling energy is shown in the display. See paragraph 3.2.4.

Measuring current and power

Measuring current is only sent through the temperature sensors during the short duration of the temperature measurement. The effective power that is deposited in the sensor elements is thus minimal, and its influence on the self-heating of the temperature sensors is typically less than 1/1000 K.

	Pt500
Measuring current	< 0,5 mA
Peak power	< 0,2 mW
RMS power ("fast mode")	< 2 μ W
RMS power ("normal mode")	< 0,4 μ W

Average temperatures

MULTICAL® 303 continuously calculates the average temperatures of inlet and outlet (t_1 and t_2) in °C without decimals, and the background calculations E8 and E9 ($m^3 \times t_1$ and $m^3 \times t_2$) are carried out with every volume counting (e.g. with every 0,01 m^3 if the meter size is qp 1,5), whereas the display is updated with every integration (depending on the L-code). The average calculations are thus volume-weighted and can be used directly for checking purposes.

7.6 Information code types

MULTICAL® 303 constantly monitors a number of important functions. If a serious error occurs in the measuring system or installation, a flashing “INFO” appears in the display. The “INFO” field keeps flashing as long as the error is present no matter which reading you select. The “INFO” field automatically disappears when the reason for the error has been removed.

Note Configuration of “Manual reset of info code” is not possible in MULTICAL® 303.

7.6.1 Information code types on the display

In MULTICAL® 303, each digit of the info code is dedicated to one of the meter’s subelements. For example, the second digit from the left in the display is always related to information on temperature sensor t1. At the same time, the info code is divided according to sections so that a reading from left to right consists of: General information, temperature information (t1 and t2) and flow information (V1), see table below for an overview of info codes.

Display digit								Description	Bit format ²
1	2	3	4	5	6	7	8		
Info	t1	t2	-	V1	-	-	-		
1								No voltage supply ¹	1
2								Low battery level	2
	1							t1 Above measuring range or disconnected	8
		1						t2 Above measuring range or disconnected	16
	2							t1 Below measuring range or short-circuited	32
		2						t2 Below measuring range or short-circuited	64
	9	9						Invalid temperature difference (t1-t2)	128
				3				V1 Air	256
				4				V1 Wrong flow direction ³	512
				6				V1 > q _s for more than an hour	2048

¹ This info code parameter does not appear from the current info code as it is only active when the meter is without supply. The info code is saved in the info log and it will appear from the info log that the meter has been without power supply.

² It is possible to see the information code in bit format using MeterToolX/HCW. In case of several simultaneous information codes, the sum of all the codes will be shown. The information code is sent in bit format via data communication as well.

³ This info code is set when there has been a flow in the wrong direction with minimum 1% of q_p for at least 10 minutes. It is reset at the first flow measurement with correct flow direction.

Note Info codes are configurable. Therefore, it is not certain that all above-mentioned parameters are available in a given MULTICAL® 303. This depends on the selected country code.

7.6.2 Examples of information codes



Flashing “INFO”

If the information code is different from “00000000”, a flashing “INFO” appears in the meter’s display.

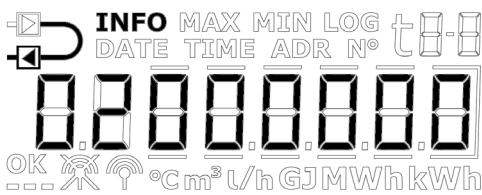

Current information code

The current info code can be displayed by scrolling to the reading using the key on the calculator front. When the current info code is displayed, “INFO” stops flashing.

The current info code in the example indicates that t1 is below the measuring range or short-circuited.

The below-mentioned data are only available in “TECH loop”

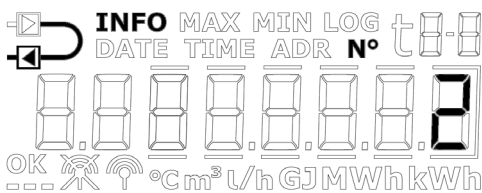

Info event counter

By activating the meter’s key when the info code is displayed in reading 2-010 and then selecting 2-010-01, information on how many times the info code has been changed is shown.

The value is increased every time the info code is changed.

The info event counter of a new meter will be 0 as the transport state prevents counting during transportation.

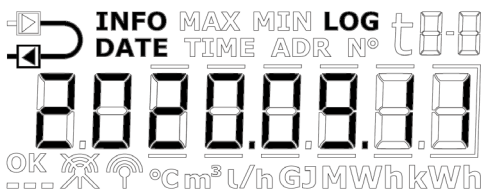

Info logger

If you activate the key again, reading 2-010-02 shows the info code data logger.

The first display reading states the date of the latest info code change.

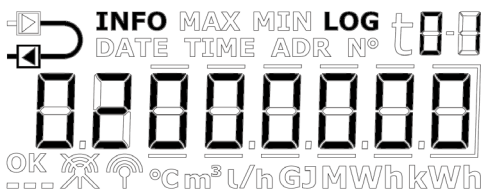

When activating the key again, reading 2-010-03 displays the info code from the above date.

Repeated activations of the key alternately induce dates and corresponding info codes.

The data logger saves the latest 50 changes (all 50 changes can be displayed) and the rest can be shown via MeterToolX/HCW.

Note In addition, the info code is saved in the meter’s data logger for diagnostic purposes.

7.6.3 Information codes in display and in serial communication

Display

The info code types that are related to the meter’s different sensors t1, t2 and V1 will, in case of error, influence the display readings, to which they are tied. In connection with current values for temperatures, flow and power, three horizontal lines appear in the display, and the energy registers, in which counting is dependent on the sensor function, are not accumulated. See paragraph 6 for further details on sensor errors.

Temperature sensor error

The error can be due to the sensor being disconnected or short-circuited. A wrong temperature difference ($\Delta\theta$) alone will not be considered a temperature sensor error.

In case of an error in one or more temperature sensors (t1 and t2), the value of the serial communication of the sensor in question will be 0,00 °C (lowest valid temperature) or 185,00 °C (highest valid temperature), respectively, depending on the measurement being below range (sensor short-circuited) or above range (sensor disconnected). The display reading of the sensor in question shows lines in the three digits to the far right in the display, independent of the cause of the error. Decimal points are not shown.

The display readings temperature difference ($\Delta\theta$) and current power will also show three lines for errors in one or more temperature sensors. In serial communication, the power value will be 0,0 kW.

Flow sensor error

The error can be due to air in the flow sensor (V1) or due to the fact that it has been mounted with wrong flow direction. For MULTICAL® 303, there are no functional limits in the period in which the meter operates above q_p . A flow higher than q_p is thus not considered an error in this connection.

In case of errors in the flow sensor, the value of the flow in the serial communication will be 0 l/h. The display reading of current flow shows lines in the three digits to the far right in the display. Decimal points are not shown.

The display reading of current power will also show three lines for errors in the flow sensor. In serial communication, the power value will be 0,0 kW.

Serial communication

Bit	Value	Info
0	1	Supply voltage disconnected
1	2	Low battery level
3	8	t1 Above measuring range or disconnected
4	16	t2 Above measuring range or disconnected
5	32	t1 Below measuring range or short-circuited
6	64	t2 Below measuring range or short-circuited
7	128	Wrong Δt (t1-t2)
8	256	V1 air
9	512	V1 Wrong flow direction
10	1024	-
11	2048	V1 Increased flow (flow1 > q_s , for more than 1 hour)

7.6.4 Information codes in transport state

The meter leaves the factory in transport state, i.e. the info codes are active in the display, but not in the meter's data logger. This prevents info events from being counted and non-relevant data from being saved in the info log during transportation. The first time the meter registers flow after the installation, the info code automatically becomes active.

7.7 Transport state

The meter is in transport state until it makes its first integration.

Transport state means:

- No info codes are saved in the meter's logger and the info event counter is not active.
- A power-saving measuring sequence is used.
- "SETUP loop" is accessible, which enables you to configure the meter before commissioning.

Note: In general, "SETUP loop" is available. It can, however, be limited by the selected country code.

Please be aware that the access to "SETUP loop" will be blocked and the meter will leave transport state if the configuration in "SETUP loop" is ended by the function "EndSetup". When the meter has left transport state, info codes will be logged and the measuring sequence is changed to the one ordered for the meter (determined by the L-code). The meter cannot revert to transport state unless a total reset is made. The access to "SETUP loop" can, however, be opened again by breaking the label "SETUP" on the back of the calculator and short-circuit the contact points under this. This means breaking the installation seal, see paragraph 4.9.

Radio communication

On delivery, the meter is in transport state and the meter's radio communication is deactivated. The radio is activated by the first integration that the meter carries out. In transport state and after commissioning of the meter, the radio can be enabled via "SETUP loop". Enabling the radio does not cause the meter to leave transport state.

TEST mode

Access to "TEST loop" disables the radio communication. In "TEST loop", an integration does not enable the radio.

Note To gain access to "TEST loop", the test seal must be broken and the meter must be reverified subsequently.

Flow chart

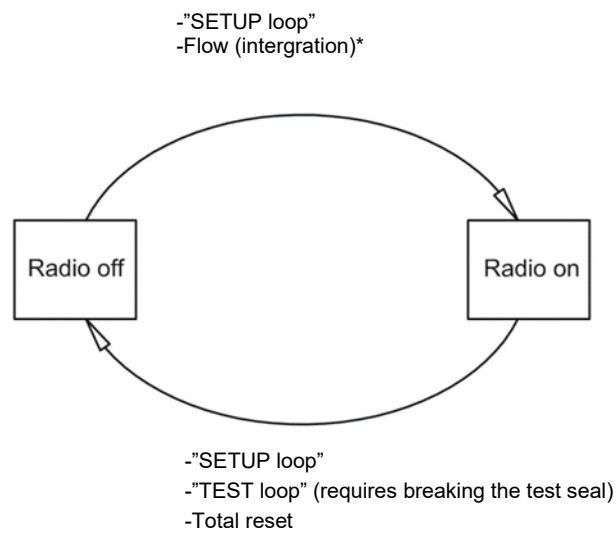

*If the meter is in "TEST loop" the radio remains off at flow (intergration) and forced call

7.8 Info and config. logger

7.8.1 Info logger

Every time the information code changes, the below-mentioned registers are logged.

Register type	Description
Date (20YY.MM.DD)	Year, month and day of logging time
Clock (hh.mm.ss)	Time
Info	Information code on above date
E1	Heat energy
E3	Cooling energy
V1	Volume

It is possible to data read the latest 50 changes of the information code as well as the dates on which the changes were made. When the information code is read from the display, all of the 50 changes including dates can be read. All of the 50 changes can also be read by means of the MeterToolX/HCW.

Info event

Every change of a parameter of the info code results in an info event if the selected country code is configured with this parameter. It is thus not certain that all parameters result in an info event.

An info event results in accumulation of the info event counter as well as logging in the info logger. This does not apply as long as the meter is in transport state.

Reconfiguration of active parameters of the info code will influence future info codes, whereas all logged info codes remain as they were at the time of logging.

7.8.2 Config. logger

Every time the configuration is changed, the below-mentioned register types are logged. It is thus possible to data read the latest 25 changes of the information code as well as the dates on which the changes were made. The meter allows only 25 changes unless you break the legal seal and carry out a total reset of the meter, which also resets the config. log.

Register type	Description
Date (20YY.MM.DD)	Year, month and day of change
Hour (hh.mm)	Time
Configuration number	Meter configuration number of meter and communication (XXX-YY-ZZZ)
E1, E3 and V1	Counts are saved just after reconfiguration
Hour counter	Hour counter is saved
t offset	The temperature offset value is saved

The meter always carries out a config. logging if the user has had access to "SETUP loop", no matter whether the user has changed the configuration or not.

7.9 Summer/standard time adjustment

MULTICAL® 303 is available with configuration for DST (Daylight Saving Time ~ summer/standard time). The meter’s country code determines the DST configuration algorithm so that it corresponds to the DST regulations of the country for which the meter is intended. If the meter is configured with DST and you do not want to use it, the DST function can be disabled in MeterToolX/HCW. The DST function influences the meter’s internal clock. Time stamps for loggings of events and values are saved in standard time together with information on the current DST offset. The information on DST offset is removed from all logged time stamps if the DST function is disabled in the meter and vice versa if the DST function is enabled again.

DST and loggers: Time stamps for logging always follow the meter’s configuration. For example, a meter with enabled DST function logs data at 00.00 during standard time and at 01.00 a.m. during summer time (DK example). If the DST function is disabled after delivery and historical logger values are subsequently read, DST offset of previous values will reflect the new configuration and be removed from the time stamp. See the example in the below-mentioned table. Read logging times always reflect the current DST status.

	DST activated	DST deactivated
Logger target date	Logging time	Logging time
1 January	00:00	00:00
1 February	00:00	00:00
1 March	00:00	00:00
1 April	01:00	00:00
1 May	01:00	00:00
1 June	01:00	00:00
1 July	01:00	00:00
1 August	01:00	00:00
1 September	01:00	00:00
1 October	01:00	00:00
1 November	00:00	00:00
1 December	00:00	00:00

DST and max/min. values: Time stamps on logging of max/min. values follow standard time. If the time stamp of a value is read, it is stated with the current DST offset. If the DST function is disabled upon delivery, DST offset is removed from the time stamps of historical values as it is done with the loggers.

DST and serial read-out of logging data: Data can either be read from a register including time in standard time and DST offset as two separate parameters or alternatively from a register including time comprising DST offset as a parameter. If the DST function is disabled upon delivery, information on DST offset is removed from time stamps related to the historical values.

8 Flow sensor

Throughout more than 30 years, ultrasonic measurement has proved accurate and the most long-term stable measuring principle for heat measurement. Experience from repeated reliability tests carried out in Kamstrup's accredited long-term test equipment and at AGFW in Germany as well as from ultrasonic meters in operation has documented the long-term stability of ultrasonic meters (see, for example, the report on random sampling of flow sensors, Kamstrup A/S, doc. 5811-6549).

8.1 Measuring principles

Within ultrasonic flow measuring, there are two main principles: the transit time method and the Doppler method.

The Doppler method is based on the frequency change which occurs when sound is reflected by a moving particle. This is the effect you experience when a car passes you. The sound (the frequency) decreases when the car passes by.

The transit time method used in MULTICAL® 303 utilizes the fact that it takes an ultrasonic signal sent in the opposite direction of the flow longer to travel from sender to receiver than a signal sent in the same direction as the flow.

A piezo-ceramic element is used for transmitting and receiving ultrasound. The thickness of the element changes when exposed to an electric field (voltage) and thus, it functions as a transmitter of ultrasound. When the element is mechanically influenced, it generates a corresponding electric voltage and thus functions as a receiver of ultrasound.

8.2 Signal path and flow calculation

The most important elements of the signal path in MULTICAL® 303 are shown in *Figure 14*: Piezo-electric elements transmit and receive the ultrasound signal, which is reflected into and through the measuring tube to the receiver. Due to superposition of velocities of water and sound signal, ultrasound spreads faster with the flow than against the flow. As it is proven by the calculations below, the average flow velocity is directly proportional to the transit time difference of ultrasound signals that are sent with or against the flow.

The sound path is parallel to the pipe axis. The emitted sound waves cover the pipe area of these meters reasonably well and thus, the measuring signal is stable enough towards flow variations along the pipe diameter.

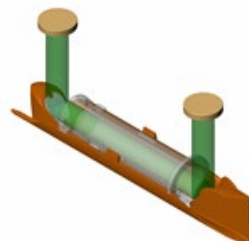

q_p 0,6...2,5 m³/h

Parallel measurement

Figure 14: Signal paths in MULTICAL® 303. Sound signals are sent from the transducers via 2 reflectors.

MULTICAL® 303

For calculation of the transit time difference, we only view a simple example with a sound path parallel to the measuring pipe. The signal path along the flow is crucial and the transit time to the measuring distance l is calculated as:

$$t = \frac{l}{c \pm v}$$

where:

t is the transit time from sender to receiver of the sound signal along the measuring distance l [s]

l is the measuring distance [m]

c is the sound propagation velocity in stagnant water [m/s]

v is the average flow velocity of water [m/s]

The transit time difference can be expressed as the difference between the absolute time of the signal sent against the flow (-) and the signal sent with the flow (+).

$$\Delta t = \frac{l}{c - v} - \frac{l}{c + v}$$

which can also be written as:

$$\Delta t = l \frac{(c + v) - (c - v)}{(c - v)(c + v)} \Rightarrow \Delta t = l \frac{2v}{c^2 - v^2}$$

As $c^2 \gg v^2$, v^2 can be omitted and the formula reduced as follows:

$$v = \frac{\Delta t \times c^2}{2l}$$

Thus, we know the basic connection between the average flow velocity and the transit time difference.

The transit time difference in a flow sensor is very small (nanoseconds). Therefore, the time difference is measured as a phase difference between the two 1 MHz sound signals in order to obtain the necessary accuracy.

Furthermore, MULTICAL® 303 takes the influence of the temperature of the water into account, i.e. the built-in ASIC uses the sound velocity at the water's current temperature in connection with the flow calculations.

The flow (volume flow rate) is then determined by measuring the transit time difference, calculating the average flow velocity and multiplying it by the area of the measuring tube:

$$q = v \times A$$

where:

q is the flow (volume flow rate) $\left[\frac{m^3}{h} \right]$

A is the area of the measuring pipe $[m^2]$

The volume V passing through is finally calculated as a time integration over the flow (multiplication of (cross section constant) flow by time).

8.3 Flow limits

In the meter's whole working range from min. cut-off and far beyond q_s , there is a linear connection between the flow rate and the measured water flow.

In practice, the highest possible water flow through the meter will be limited by the pressure in the system or by possible cavitation due to too low back pressure.

If the flow is lower than cut-off or negative (reverse flow direction), MULTICAL® 303 does not measure any flow.

According to EN 1434, the upper flow limit q_s is the highest flow at which the flow sensor may operate for short periods of time (< 1 h/day, < 200 h/year) without exceeding the max permissible error. For MULTICAL® 303, there are no functional limits in the period in which the meter operates above q_p . Please note, however, that high flow velocities may cause cavitation, especially at low static pressure. See paragraph 4.5 for further details on operating pressure.

9 Temperature sensors

A platinum resistance thermometer utilizes the fact that the precious metal platinum has a very well-defined correlation with its resistance and the temperature. The correlation between the resistance and the temperature is defined in the standard EN 60751 (DIN/IEC 751). On MULTICAL® 303, Pt500 temperature sensors are used if the nominal ohmic resistance is 500,000 Ω at 0,00 °C and 692,528 Ω at 100,00 °C.

The correlation between the resistance R_t and the temperature t is defined by:

$$R_t = R_0(1 + At + Bt^2)$$

where R_0 indicates the resistance at 0,00 °C, whereas A and B are constants. The values R_0 , A and B are determined by the verification of temperature sensor that is performed according to EN 1434-5.

In a heat or cooling meter, a temperature sensor set is used for measuring the temperature difference between inlet and outlet. Each of the two temperature sensors has its own values for R_0 , A and B and thus, the requirement for an approved temperature sensor set, according to EN 1434-1, is that the maximum difference in percent between the two temperature sensors, E_t , in the entire approval area must be maximum:

$$E_t = \pm \left(0,5 + 3 \frac{\Delta\theta_{min}}{\Delta\theta} \right)$$

where $\Delta\theta$ is the specific temperature difference and $\Delta\theta_{min}$ is the minimum approved temperature difference, normally 3 degrees. The values R_0 , A and B of the individual temperature sensors as well as E_t appear from the certificate of the temperature sensor set.

The table below shows the resistance values in [Ω] for each degree Celsius for Pt500 temperature sensors:

Pt500										
°C	0	1	2	3	4	5	6	7	8	9
0	500,000	501,954	503,907	505,860	507,812	509,764	511,715	513,665	515,615	517,564
10	519,513	521,461	523,408	525,355	527,302	529,247	531,192	533,137	535,081	537,025
20	538,968	540,910	542,852	544,793	546,733	548,673	550,613	552,552	554,490	556,428
30	558,365	560,301	562,237	564,173	566,107	568,042	569,975	571,908	573,841	575,773
40	577,704	579,635	581,565	583,495	585,424	587,352	589,280	591,207	593,134	595,060
50	596,986	598,911	600,835	602,759	604,682	606,605	608,527	610,448	612,369	614,290
60	616,210	618,129	620,047	621,965	623,883	625,800	627,716	629,632	631,547	633,462
70	635,376	637,289	639,202	641,114	643,026	644,937	646,848	648,758	650,667	652,576
80	654,484	656,392	658,299	660,205	662,111	664,017	665,921	667,826	669,729	671,632
90	673,535	675,437	677,338	679,239	681,139	683,038	684,937	686,836	688,734	690,631
100	692,528	694,424	696,319	698,214	700,108	702,002	703,896	705,788	707,680	709,572
110	711,463	713,353	715,243	717,132	719,021	720,909	722,796	724,683	726,569	728,455
120	730,340	732,225	734,109	735,992	737,875	739,757	741,639	743,520	745,400	747,280
130	749,160	751,038	752,917	754,794	756,671	758,548	760,424	762,299	764,174	766,048
140	767,922	769,795	771,667	773,539	775,410	777,281	779,151	781,020	782,889	784,758
150	786,626	788,493	790,360	792,226	794,091	795,956	797,820	799,684	801,547	803,410
160	805,272	807,133	808,994	810,855	812,714	814,574	816,432	818,290	820,148	822,004
170	823,861	825,716	827,571	829,426	831,280	833,133	834,986	836,838	838,690	840,541
180	842,392	844,241	846,091	847,940	849,788	851,635	-	-	-	-

Pt500, IEC 751 Amendment 2-1995-07

Table 5

9.1 Temperature sensor types

MULTICAL® 303 is delivered with TemperatureSensor 63. The required temperature sensor set is selected through the meter's type number. The table below shows the available temperature sensor sets. See the meter's complete type number in paragraph 3.1.

Sensor set (Pt500)	Length [mm]	Diameter Ø [mm]	Cable length [m]	
DS 27,5 mm direct short temperature sensor set	27,5	-	1,5	51
DS 27,5 mm direct short temperature sensor set	27,5	-	3,0	52
Ø5,0 mm direct temperature sensor set	-	5,0	1,5	61
Ø5,0 mm direct temperature sensor set	-	5,0	3,0	62
Ø5,2 mm direct temperature sensor set	-	5,2	1,5	71
Ø5,2 mm direct temperature sensor set	-	5,2	3,0	72

9.2 DS 27,5 mm direct short temperature sensor

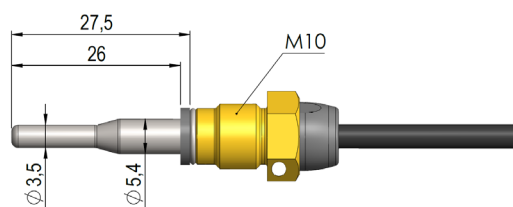

Kamstrup TemperatureSensor 63 direct short DS 27,5 mm temperature sensor has been designed according to the European standard for heat energy meters EN 1434-2. The sensor is constructed to be mounted directly in the measuring medium, i.e. without sensor pocket, by which you obtain an extremely fast response to temperature changes from, for example, domestic water exchangers. The temperature sensor tube has a diameter of Ø3,5, is made of stainless steel and the temperature sensor element itself is placed in the tube. The temperature sensor is approved for both PN16 and PN25 installations, with PS25 as the maximum pressure. The sensor is based on two-wire silicone cable and can thus be used at medium temperatures up to 150 °C. One temperature sensor is mounted in the flow sensor from the factory and thus, only the other temperature sensor must be mounted. As shown in *Figure 15* and *Figure 16*, this can be mounted by means of, for example, a nipple or a ball valve.

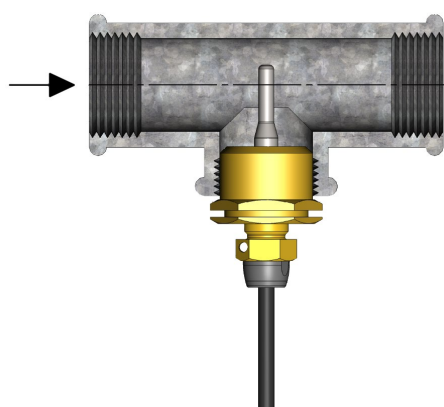

Figure 15

As shown in *Figure 15*, the DS 27,5 mm direct short temperature sensor can be mounted by means of an R½ or R¾ for M10 nipple in a standard 90° tee.

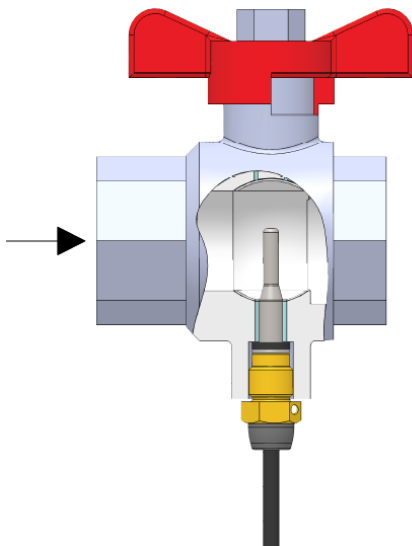

Figure 16

To obtain the best possible serviceability during meter exchange, the direct short temperature sensor can be placed in a ball valve with sensor socket, see *Figure 16*.

Ball valves with sensor socket are available in G½ and G¾, which both fit the DS 27,5 mm temperature sensor.

No.	6556-474	6556-475
	G½	G¾

9.3 Ø5,0 mm / Ø5,2 mm temperature sensors

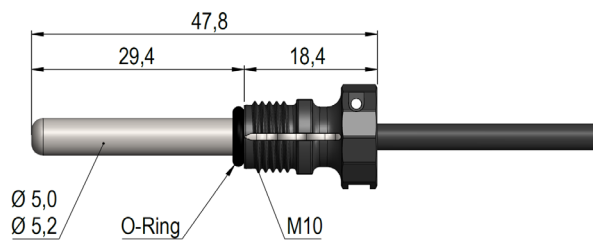

Both Ø5,0 mm and Ø5,2 mm temperature sensors are delivered with mounted composite unions and this is why they by default must be used as direct temperature sensor. The composite unions can be removed (see paragraph 9.3.2) after which the temperature sensors can be used for installation in pockets. The temperature sensors are made from stainless steel and have diameters of Ø5,0 mm or Ø5,2 mm. The temperature sensors are approved for both PN16 and PN25 installations, with PS25 as the maximum pressure. The temperature sensors are based on a 2-wire silicone cable and can thus be used at media temperatures up to 150 °C. This also applies to the composite union that is made from the material PPS. One of the temperature sensors is mounted in the flow sensor from the factory and thus, only the other temperature sensor must be mounted if you choose to mount both temperature sensors as direct temperature sensors. The use of asymmetric sensor installation (one temperature sensor installed as a direct temperature sensor and the other as a pocket sensor) may only be performed when national regulations allow this and never in installations with low differential temperature and/or low water flow.

9.3.1 Installation of $\varnothing 5,0$ mm / $\varnothing 5,2$ mm temperature sensors as direct temperature sensors

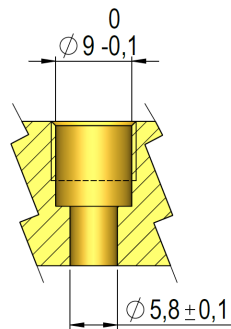
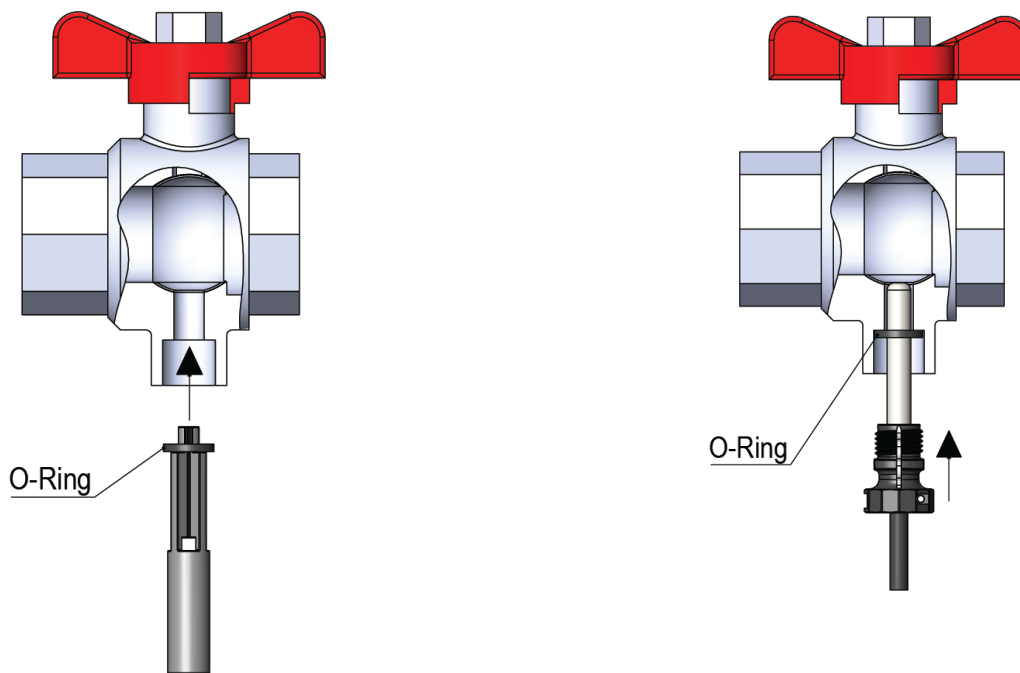
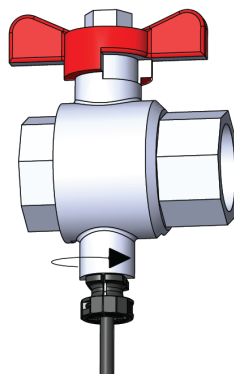

Figure 17: Measurement and tolerance requirements at installation of direct $\varnothing 5,0$ mm or $\varnothing 5,2$ mm temperature sensor.

No matter where the direct $\varnothing 5,0$ mm or $\varnothing 5,2$ mm temperature sensor is installed, it is very important to observe the tolerances stated in *Figure 17*. If not, the O-ring may not provide correct sealing. To avoid damaging the O-ring at installation, it is important to use the provided guide when installing $\varnothing 5,0$ mm or $\varnothing 5,2$ mm temperature sensors as direct temperature sensors.



The O-ring guide is used for pushing the O-ring into place after which the temperature sensor can be pushed to the bottom.



The composite union is tightened by hand. Do not use any tools.

9.3.2 Installation of Ø5,0 mm / Ø5,2 mm temperature sensors as pocket sensors

If you want to use Ø5,0 mm or Ø5,2 mm temperature sensors as pocket sensors, first remove the temperature sensor that is mounted in the sensor connecting pipe of the flow sensor. Please make sure that the O-ring of the temperature sensor O-ring is also removed. As shown in the illustration below, a blind plug is then mounted (with O-ring) in the sensor connecting pipe.

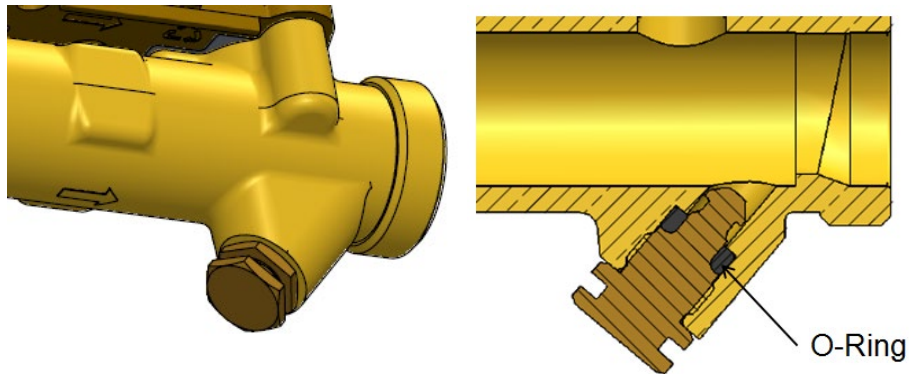

Then, the composite unions are removed from both temperature sensors by hand as shown in the following figure.



The temperature sensors can then be installed in sensor pockets.

9.4 Identification of inlet and outlet temperature sensors

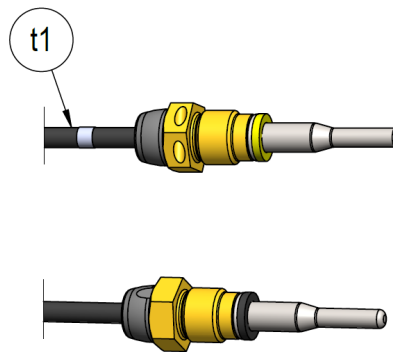

To make it easier to perform a correct installation, the inlet temperature sensor has been added with additional two white markings on the cable, enabling you to easily identify which of the two temperature sensors are inlet and outlet temperature sensors, respectively. The white marking is placed right after the temperature sensor itself, see the figure above, and makes it easy to check that the inlet temperature sensor is installed in the inlet pipe. The other white marking is placed at the end of the cable, see the figure below, and in connection with reverification, it can be used for checking that the temperature sensors are subsequently correctly mounted in the calculator. Identification of inlet and outlet temperature sensors can likewise be seen on the label attached to the temperature sensors.

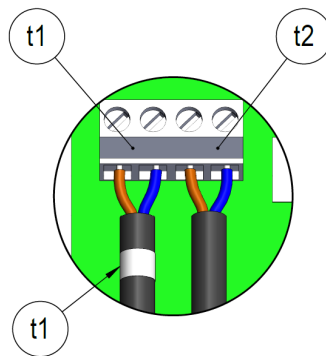

10 Voltage supply

MULTICAL® 303 is powered via 1 or 2 built-in A-cell lithium batteries. The option of 1 or 2 batteries is selected when ordering the meter.

Supply

Battery, 1 x A-cell	1
Battery, 2 x A-cell	9

10.1 Battery lifetimes

Overview, estimated lifetime [years], for differently configured MULTICAL® 303.

	Normal mode (32 s) Adaptive mode (4-64 s)		Fast mode (4 s)	
	Wall-mounted Battery < 30 °C	Mounted on flow sensor Battery < 40 °C	Wall-mounted Battery < 30 °C	Mounted on flow sensor Battery < 40 °C
Type no.: 303-xxxxxx-xx120 M-Bus, configurable	1 x A-cell: 10 years	1 x A-cell: 8 years	1 x A-cell: 5 years	1 x A-cell: 4 years
Type no.: 303-xxxxxx-xx130 Wireless M-Bus, 868 MHz, configurable				
Type no.: 303-xxxxxx-xx920 M-Bus, configurable	2 x A-cell: 16 years	2 x A-cell: 14 years	2 x A-cell: 9 years	2 x A-cell: 8 years
Type no.: 303-xxxxxx-xx930 Wireless M-Bus, 868 MHz, configurable				

Conditions for above-mentioned calculations of battery lifetime:

- M-Bus: Max 1 reading every 120 s.
- wM-Bus x30-10-101, Drive-By 16 s, 10 mW, Standard registers

Longer battery lifetimes than those mentioned above can be obtained, for example by:

- Carrying out M-Bus readings at longer intervals than 120 s.
- Adapting the wM-Bus configuration to a shorter datagram, a longer transmission interval or a smaller transmission power.

Please contact Kamstrup A/S for further information.

10.2 Replacement of batteries

Batteries should not be replaced on the installation site as this requires opening the calculator and thus breaking the verification seal of the meter. This means that the meter must be reverified subsequently by an authorised laboratory if it is to be used for billing after the battery replacement. After reverification, the meter must be resealed with void label. If the battery package is replaced from one battery to two batteries or vice versa, it is possible to change the dynamic part of the type number so that it matches the installed battery package. This is done via MeterToolX/HCW and solely has an informative purpose and no technical meaning.

11 Communication

MULTICAL® 303 can be delivered with either M-Bus or Wireless M-Bus. In both cases, the communication is embedded in the meter and can thus not be changed upon delivery. However, it is possible to adapt the datagram contents of both types of configuration upon delivery, while parameters such as transmission interval and transmission power can also be adapted for Wireless M-Bus.

Both communication types are included in the type test of MULTICAL® 303.

11.1 Communication types

MULTICAL® 303 comes in two versions with either M-Bus or wM-Bus. The communication is configurable, which means that the system configuration (YY) containing transmission power, transmission interval and modes for wM-Bus can be adapted to specific needs. Likewise, the datagram contents (ZZZ) can be adapted to individual needs for both wM-Bus and M-Bus.

The technical description for M-Bus is document number 5512-2760 and for Wireless M-Bus 5512-2761.

11.1.1 M-Bus, type: 20

M-Bus allows communication up to once per 120 second without influencing the battery lifetime of the meter, more frequent requests are, however, possible.

M-Bus in MULTICAL® 303 supports both primary, secondary and enhanced secondary addressing. M-Bus automatically selects communication speed between 300 and 2400 baud.

11.1.2 Wireless M-Bus, 868 MHz, type: 30

Wireless M-Bus has been developed for Wireless M-Bus systems operating within the licence free band of 868 MHz.

The communication protocol is C-mode or T-mode according to EN13757-4. The number of registers in the data package, transmitting power and the transmitting interval influence the battery lifetime of MULTICAL® 303. See more in paragraph 10.1.

11.2 Communication configuration >XXX-YY-ZZZ<

The meter’s communication configuration consists of a combined type/configuration number XXX-YY-ZZZ, see also paragraph 3 about type overview. The type/configuration number indicates the communication hardware, system configuration and datagram contents.

11.2.1 Hardware configuration >XXX<

The XXX-code is tied to the meter's type number and choice of hardware and can thus not be changed upon delivery. The XXX-code consists of meter type and communication type from the meter's type number, see more in paragraph 3.1. For example, a heat meter (MID module B+D) with wireless M-Bus will have XXX-code 230 and a bifunctional heat/cooling meter (MID module B+D & TS27.02+DK268) with θ_{hc} = off and M-Bus will have XXX-code 320.

	Static data 303-XXXXXX - Written on the meter's front				Dynamic data XXXXX Shown in display		
Type 303 -	□	□□	□	□□	□□	□	□□
Sensor connection	x						
Flow sensor		xx					
Meter type							
Heat meter (MID module B+D)							2
Heat/cooling meter (MID module B+D & TS27.02+DK268)			θ_{hc} = off				3
Heat meter, National approvals							4
Cooling meter (TS27.02+DK268)							5
Heat/cooling meter (MID module B+D & TS27.02+DK268)			θ_{hc} = on				6
Country code				xx			
Sensor set (Pt500)		Length	Diameter \varnothing	Cable length		xx	
Supply						x	
Communication							
M-Bus, configurable							20
Wireless M-Bus, configurable, 868.95 MHz EU							30

Table 6: Extract of meter type number from paragraph 3.1. As it can be seen, the XXX-code consists of meter type and communication.

11.2.2 System configuration >YY<

The YY-code indicates the system configuration of Wireless M-Bus. This means that this parameter is irrelevant to M-Bus and will thus always be set to 00 for M-Bus, type: 20. The system configuration contains a number of parameters that indicate how the wireless communication is used, such as transmission interval, transmission power, frame format, etc. See examples below.

YY-code	Description
10	C1, 16 s interval, 10 mW, Walk-By/Drive By, Frame format B
11	C1, 96 s interval, 25 mW, Fixed Network, Frame format B

Table 7: Examples of YY-codes and what they mean.

11.2.3 Datagram configuration >ZZZ<

The ZZZ-code indicates the contents of the datagram that is transmitted via M-Bus and wireless M-Bus. The datagrams of the two types of communication will not be the same as M-Bus can handle a larger data package than wireless M-Bus. The concept of optional content is, however, the same. This means that there is a number of predefined ZZZ-codes with a specific content. These ZZZ-codes are optionally selectable. Below is an example in the form of ZZZ-code 101 for M-Bus and wireless M-Bus, respectively. For the creation of special ZZZ-codes, please contact Kamstrup A/S – however, note that the data sequence is fixed and cannot be changed. However, the contents can be selected or deselected.

11.2.3.1 X20-00-101: Standard Profile Yearly Target data

No.	Register Id	Register name	Logged register	Notes
1	60	Heat energy E1		
2	63	Cooling energy E3		
3	68	Volume V1		
4	97	Energy E8		
5	110	Energy E9		
6	1004	Operating hours		
7	175	Error hour counter		
8	86	t1 actual (2 decimals)		
9	87	t2 actual (2 decimals)		
10	89	t1-t2 diff. temp. (2 decimals)		
11	80	Power E1/E3 actual		
12	143	Power Max month		
13	74	Flow V1 actual		
14	139	Flow V1 max month		
15	369	Info bits		
16	348	Date and Time		
17	60	Heat energy E1	Year Log	
18	63	Cooling energy E3	Year Log	
19	63	Cooling energy E3	Year Log	HCC
20	68	Volume V1	Year Log	
21	97	Energy E8	Year Log	
22	110	Energy E9	Year Log	
23	128	Power Max year	Year Log	
24	124	Flow V1 max year	Year Log	
25	348	Date and Time (logged)	Year Log	

11.2.3.2 X30-10-101: C1, Drive by, Standard Registers

Wireless M-Bus datagram Interval: 16 s
10 mW

No.	Register Id	Register name	Logged register	Notes
1	60	Heat energy E1		
2	63	Cooling energy E3		
3	68	Volume V1		
4	97	Energy E8		
5	110	Energy E9		
6	86	t1 actual (2 decimals)		
7	87	t2 actual (2 decimals)		
8	74	Flow V1 actual		
9	369	Info bits		
10	348	Date and Time		
11	60	Heat energy E1	Month log	
12	63	Cooling energy E3	Month log	
13	68	Volume V1	Month log	
14	348	Date and Time (logged)	Month log	

12 Data communication

12.1 MULTICAL® 303 data protocol

Internal data communication in MULTICAL® 303 is based on the Kamstrup Meter Protocol (KMP) that provides a fast and flexible reading structure and also fulfils future requirements for data reliability.

The KMP protocol is used in all Kamstrup consumption meters launched from 2006 onwards. The protocol is used for the optical interface.

Integrity and authenticity of data

All data parameters include type, measuring unit, scaling factor and CRC16 checksum. Every produced meter includes a unique identification number (serial number).

12.2 Optical interface

The optical read-out head can be used for data communication via the optical interface. The optical read-out head is placed on the front of the calculator just above the IR-diode as shown in the illustration below. The cable must point upwards.

Please note that the optical read-out head includes a very strong magnet, which should be protected by means of an iron disc when not in use.

Various variants of the optical read-out head appear from the list of accessories (see paragraph 3.1.1).



Optical read-out head with Bluetooth

Note The key ring on the read-out head must point upwards.

12.2.1 Power savings in connection with the optical read-out head

To limit the power consumption of the circuit around the IR-diode, the data communication is only active for 4 minutes after the last keystroke. Thus, remember to activate the push-button on the front before initiating the data reading.

12.3 Data protocol

Utilities and other relevant companies who want to develop their own communication driver for the KMP protocol can order a demonstration program in C# (.net-based) as well as a detailed protocol description (in English language).

13 Test and calibration

MULTICAL® 303 can be tested as a complete energy meter or as a split meter depending on the available equipment.

The high-resolution test registers are read from the display, via serial data reading or via high-resolution pulses.

Before testing as a split meter, disassemble the meter and screw off the sensor set. Subsequently, the calculator is tested separately by means of the Kamstrup calibration equipment for MULTICAL® 303 and MeterToolX/HCW. Flow sensor and temperature sensors are tested separately too. During the test of the flow sensor, it is unimportant whether the temperature sensors are mounted.

For fast test/calibration of MULTICAL® 303, the meter has a test mode with an extra fast measuring sequence. In test mode, heat energy, cooling energy and volume are displayed with higher resolutions than normal to shorten the test duration.

MULTICAL® 303 uses more current in test mode but under normal circumstances, a meter is only in test mode a few times during its lifetime, and this does not influence the meter's battery lifetime.

13.1 Meter cycle

The meter supports the following three configurable modes with different measuring cycle times:

Adaptive mode L=5	Normal mode L=6	Fast mode L=7	Test mode	Key activation mode	Measuring cycle time	Flow measuring interval
			•		4 s	0.5 s (8/sequence)
•		•		•	4 s	1 s (4/sequence)
•					8 s	2 s (4/sequence)
•					16 s	4 s (4/sequence)
•	•				32 s	4 s (8/sequence)
•					64 s	4 s (16/sequence)

The flow is measured several times during each sequence. Temperature measurement and all calculations (temperature, flow, volume, energy, etc.) are carried out once per sequence.

Selection of mode

When configuring the meter, you select the integration mode, which the meter can use, under "Integration mode >L<". No matter the selected integration mode, the meter can be set in "Test mode" by breaking the test seal and short-circuiting the test points. The meter remains in test mode until the supply is disconnected and the meter is restarted or it remains in test mode for 9 hours.

13.2 Test

The following paragraph briefly describes the various functions used during test. The description is divided into flow test and calculator test.

13.2.1 Test of flow sensor

The high-resolution volume can be accessed through the serial interface or by reading the display. The high-resolution volume is used during both standing and flying start/stop.

13.2.2 Test of calculator

The calculator supports auto-integration, which is used for testing the accuracy of the temperature measurement. Auto-integration counts a simulated volume over a given number of integrations with an evenly distributed increase of volume. At each integration, the temperature of the temperature sensors is measured and with the simulated increase in volume, energy is calculated. The energy can subsequently be read either from the display or through serial communication.

Auto-integration can be started via the serial interface. If the meter has not been unlocked, auto-integration can be used, but it does not increment volume and energy in the legal registers. However, this requires that the installation seal is broken.

This function is used in connection with standing start/stop.

13.3 High-resolution volume and energy

High-resolution volume and energy are available in the display and via serial communication. See table below.

Function	Application	Value	Resolution
Display	Standing start/stop	Volume	10 mL
		Energy	1 Wh
Serially – from latest integration	Standing start/stop	Volume	10 mL
		Energy	1 Wh
Serially – interpolated instantaneous value with the meter’s time stamp	Flying start/stop	Volume	10 mL
		Energy	1 Wh

Please contact Kamstrup for further information.

13.3.1 Reading of high-resolution registers

When data reading energy and volume (E1, E3, V1), it is possible to select the standard resolution with up to 8 significant digits as shown in the meter's display. In addition, it is possible to read out the internal registers with high resolution (“HighRes”).

Below, E1 is shown as an example. The same applies to E3 and V1.

Example:

E1 = 1.234.567,8 kWh
 E1HighRes = 4.567.890,1 Wh

13.4 Temperature calibration

The temperature measurement is adjusted and calibrated during the production process and it does not require further adjustment in the meter's lifetime. The temperature circuit can only be adjusted in our factory.

13.5 Pulse interface

During test, either optical read-out head with USB plug (6699-099) for serial reading of high-resolution energy and volume registers or Pulse Interface (6699-143) with optical read-out head and connection unit for high-resolution pulse outputs is used.

Note The meter must be in test mode.



MULTICAL® 303

13.5.1 Verification pulses

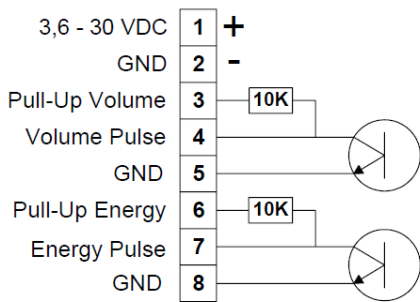

When Pulse Interface type 6699-143 is connected to power supply or battery, the unit is placed on the meter, and the meter is in test mode, the following pulses are transmitted:

High-resolution energy pulses on terminals 7 and 8

High-resolution energy pulses on terminals 4 and 5

Note For pulse resolution, see the table below.

Pulse Interface 6699-143, technical data

Supply voltage 3,6 – 30 VDC

Power consumption < 15 mA

Pulse outputs < 30 VDC < 15 mA

Pulse duration 3,9 ms

The resolution of the pulse outputs depends on the specific flow sensor size, see the table below.

Flow sensor size qp [m³/h]	Energy [pulse/kWh]	Volume [pulse/L]	Flow @ 120 Hz [L/h]
0,6	1000	100	4320
1,5			
2,5			

13.5.2 Use of high-resolution pulses

The high-resolution energy/volume pulses can be connected to the test stand used for calibration of the meter or to Kamstrup's Pulse Tester, type 6699-279, as shown in the illustration below.

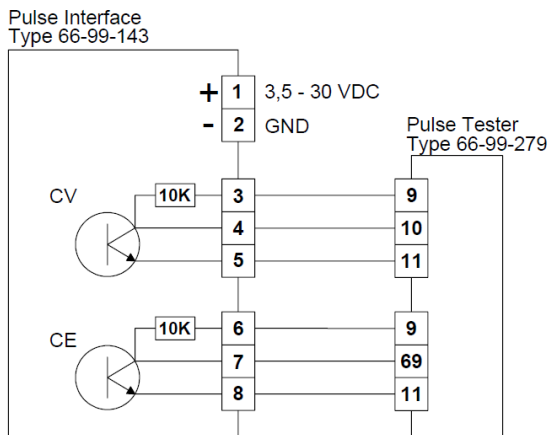

13.6 True energy calculation

During test and verification, the heat meter's energy calculation is compared to the "true energy", which is calculated according to the formula of EN1434-1:2015, EN 1434-1:2022 and OIML R 75:2002.

The below-mentioned energy calculator can be delivered electronically by Kamstrup A/S.

The true energy at the most frequently used verification points is indicated in the table below:

t1 [°C]	t2 [°C]	$\Delta\Theta$ [K]	Inlet [Wh/0,1 m ³]	Outlet [Wh/0,1 m ³]
42	40	2	230,11	230,29
43	40	3	345,02	345,43
53	50	3	343,62	344,11
50	40	10	1146,70	1151,55
70	50	20	2272,03	2295,86
80	60	20	2261,08	2287,57
160	40	120	12793,12	13988,44
160	20	140	14900,00	16390,83

14 Approvals

14.1 Type approvals

MULTICAL® 303 is type-approved according to MID on the basis of EN 1434-4:2015 and EN 1434-4:2022

MULTICAL® 303 has a national Danish cooling approval, TS 27.02 015, according to BEK 1178 based on EN 1434:2015 and EN 1434:2022.

14.2 Measuring Instruments Directive

MULTICAL® 303 is available with CE-marking according to MID (2014/32/EU). The certificates have the following numbers:

B-module: DK-0200-MI004-045

D-module: DK-0200-MID-D-001

15 Troubleshooting

MULTICAL® 303 has been constructed with a view to quick and simple installation as well as long and reliable operation at the consumer.

Should you, however, experience an operating problem, the table below can be used for troubleshooting.

Should it be necessary to repair the meter, it is recommended only to replace battery and temperature sensors. Alternatively, the whole meter should be replaced.

Major repairs must be performed by Kamstrup A/S.

Before sending the meter to Kamstrup A/S to be repaired or checked, please use the error detection table below to help you clarify the possible cause of the problem.

Symptom	Possible reason	Proposal for correction
No display function (empty display)	Power supply is missing.	The battery is discharged and should be replaced by an authorised laboratory.
No energy accumulation (e.g. MWh) and volume (m ³)	Read "INFO" in the display.	Check the error indicated by the info code. (See paragraph 7.6).
	If "INFO" = 00000000	Check that the flow direction matches the arrow on the flow sensor
	If "INFO" = xXxxxxxx, xxXxxxxx or xXXxxxxx.	Consult the "INFO" overview (paragraph 7.6) and check the temperature sensors. If defective, the sensor set must be replaced by an authorised laboratory.
Accumulation of volume (m ³), but not of energy (e.g. MWh)	Inlet and outlet sensors have been interchanged in installation.	Mount the sensors correctly.
	Heat/cooling cut-off θ_{hc} has been configured at too low value.	Reconfigure θ_{hc} at a suitable value or configure θ_{hc} at 250 °C, thereby disconnecting the cut-off function.
Incorrect temperature reading	Defective temperature sensor. Insufficient installation.	Sensor set to be replaced by authorised laboratory. Check the installation.
Temperature indication slightly too low or accumulation of energy (e.g. MWh) slightly too low	Bad thermic sensor contact. Heat dissipation. Too short sensor pockets.	Make sure that the sensors are pushed to the bottom of the sensor pockets. Insulate sensor pockets. Replace by longer pockets.

16 Disposal

Kamstrup A/S holds an environmental certification according to ISO 14001 and as part of our environment policy, we use materials that can be recovered environmentally correctly to the greatest possible extent.

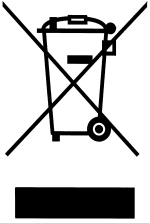

As of August 2005, Kamstrup's heat meters are marked according to the EU directive 2012/19/EU and the standard EN 50419.

The purpose of the marking is to inform our customers that the heat meter cannot be disposed of as ordinary waste.

• Disposal

Kamstrup A/S accept end-of-life MULTICAL® 303 for environmentally correct disposal according to previous agreement. The disposal arrangement is free of charge to the customer, except for the cost of transportation to Kamstrup A/S or the nearest disposal system.

The meters should be disassembled as described below and the separate parts handed in for approved destruction. The batteries must not be exposed to mechanical impact and the battery must not be short-circuited during transportation.

Item	Material	Recommended disposal
1 or 2 x A lithium cells	Lithium and thionyl chloride, approx. 0.9 g lithium per cell	Approved deposit of lithium cells
PCBs in MULTICAL® 303 (LC-display to be removed)	Coppered epoxy laminate, components soldered on	PCB scrap for metal recovery
LC-display	Glass and liquid crystals	Approved processing of LC-displays
Cables for flow sensor and temperature sensors	Copper with silicone mantle	Cable recovery
Top cover	PC + 10 % GF with TPE gaskets	Plastic recycling or combustion
Base	PC + 10 % GF	Plastic recycling or combustion
Wall bracket	PC + 20 % glass	Plastic recycling or combustion
Meter case Transducers/reflectors	Hot-pressed dezincification-proof brass < 1 % stainless steel	Metal recovery
Packaging	Environmental cardboard	Cardboard recycling (Resy)

Please send any questions you may have regarding environmental matters to:

Kamstrup A/S
 Att.: Miljø- og kvalitetsafd.
 Fax.: +45 89 93 10 01
 info@kamstrup.dk

17 Documents

	Danish	English	German
Technical description	5512-2700	5512-2701	5512-2702
Data sheet	5810-1793	5810-1794	5810-1795
Installation and user guide	5512-2725	5512-2726	5512-2727

These documents are updated regularly. Find the latest editions at:

<https://www.kamstrup.com/en-en/heat-solutions/meters-devices/meters/multical-303/documents>