

GWF 4D technology®

# sonico® EDGE

ULTRASONIC FLOW METER

Rev. 11 (02/2026)



**GWF AG**

Obergrundstrasse 119  
6005 Lucerne, Switzerland

T: +41 41 319 50 50  
info@gwf.ch

**Support:**

T +41 41 319 52 00  
support@gwf.ch

Copyright © 2026 GWF AG

All rights reserved. No part of this documentation may be reproduced in any form, stored, or transferred, neither electronically, mechanically, photo-technically, by recording on data media, still otherwise, as long as no expressly written authorization of the publisher is present.

We reserve the right, to change the described products without prior notice. This publication can be updated and modified without prior notice.



# Table of Content

<b>1. General information</b>	<b>8</b>
1.1. Data protection and security	8
1.2. Liability	8
1.3. EU Conformity declaration	8
1.4. Warnings and safety symbols	8
1.5. Trademarks	8
<b>2. General safety instructions</b>	<b>9</b>
2.1. Requirements for the personnel	9
2.2. Intended use	9
2.3. Operational safety	9
2.4. Product safety	9
2.5. Electrical safety	10
2.6. IT security	11
<b>3. Product Description</b>	<b>12</b>
3.1. Product dimensions	12
3.2. Product design	13
3.3. Seals	13
3.4. Applications	14
3.5. 4D technology®	15
<b>4. Incoming inspection</b>	<b>17</b>
4.1. Scope of delivery	17
4.2. Checklist incoming acceptance	18
4.3. Nameplate	18
<b>5. Storage / Transport</b>	<b>19</b>
5.1. Storage	19
5.2. Transport	19
5.3. Packaging disposal	19
<b>6. Installation / Mounting</b>	<b>20</b>
6.1. General requirements	20
6.2. Installation conditions	20
6.3. Environment and process requirements	21
6.4. Checklist installation preparation	22
6.5. Mounting	22
6.5.1. Torques and pressures	22

<b>7. Electrical connection</b>	<b>23</b>
7.1. Checklist electrical connection: tools and requirements	24
7.2. Power supply meter	24
7.2.1. Technical specification for power transformer	24
7.2.2. Power cable and joint connection	24
7.3. Checklist electrical connection: final inspection	24
<b>8. Display and meter activation</b>	<b>25</b>
8.1. Display symbols	25
8.2. Meter activation	26
8.3. Default display sequence	26
8.4. Test bench mode	27
<b>9. Internal data logger</b>	<b>28</b>
9.1. Access and activation	28
9.2. Data logger content per entry	28
9.3. Data storage capacity	28
9.4. Data logger retrieval	28
<b>10. Tariff</b>	<b>29</b>
10.1. Tariff volumes general	29
10.2. Operating modes	29
10.3. Setting and viewing tariff volumes	29
10.4. Volume mode	29
10.5. Time mode	29
10.6. Flowrate mode	29
<b>11. IR interface (optohead) and sonico® LIFE application</b>	<b>30</b>
11.1. Activation of IR interface	30
11.2. Sonico® LIFE to enable legal meter information	31
11.3. Removal of optohead	31
<b>12. Communication modules</b>	<b>31</b>
12.1. Exchanging or adding communication modules	32
12.2. Connection schematics communication modules	33
<b>13. Error codes and troubleshooting</b>	<b>34</b>
<b>14. Dismounting and disposal</b>	<b>35</b>
14.1. Dismounting	35
14.2. Disposal	35
14.3. Recycling	35
14.3.1. Product recycling and disposal (Europe only)	35
14.4. Return / Repair	35

<b>15. Technical data and certification</b> .....	<b>36</b>
15.1. Metrological data.....	36
15.2. Environmental specifications and certification .....	36
15.3. EU declaration of conformity .....	37
<b>16. Spare parts and accessories</b> .....	<b>38</b>
16.1. Available accessories .....	38
16.2. Communication modules.....	38
16.3. Spare parts .....	38
<b>17. Annex</b> .....	<b>39</b>
17.1. Checklists .....	39
17.1.1. Checklist incoming acceptance ←.....	39
17.1.2. Checklist installation preparation ←.....	40
17.1.3. Checklist electrical connection: tools and requirements ←.....	40
17.1.4. Checklist electrical connection: final inspection ←.....	40
17.2. Document revision history.....	40

## List of figures

Fig. 1: Dimensions of sonico® EDGE with (right) and without (middle) external NFC modules .....	12
Fig. 2: Parts of the sonico® EDGE .....	13
Fig. 3: Calibration seal .....	13
Fig. 4: Meter cap as seal for electronics .....	14
Fig. 5: Communication seal for modules.....	14
Fig. 6: Illustration of time of flight measurement principle.....	15
Fig. 7: Ultrasonic pulse sent in standing water.....	15
Fig. 8: Meter-specific base signal received in standing water .....	15
Fig. 9: Time-reversed base signal forms the TRA reference signal.....	15
Fig. 10: Every sonico® EDGE meter has an individual TRA signal .....	16
Fig. 11: The reference signals received with and against flow direction are overlapped.....	16
Fig. 12: Scope of delivery.....	17
Fig. 13: Optional accessories.....	17
Fig. 14: Exemplary name plate (DN 50 meter) .....	18
Fig. 15: Lifting instructions .....	19
Fig. 16: Schematic illustration of bolt tightening to flanges .....	22
Fig. 17: Electrical connection scheme and part list of sonico® EDGE meter power supply .....	24
Fig. 18: Scheme of all segments visible on sonico® EDGE display .....	25
Fig. 19: Standard display of volume with three decimals.....	26
Fig. 20: Empty pipe warning appears during installation of the meter.....	26
Fig. 21: Exemplary screenshot of forward flow volume register as shown in display sequence .....	27
Fig. 22: Exemplary screenshot of back flow volume register as shown in display sequence .....	27
Fig. 23: Example of display during activated test bench mode. ....	27
Fig. 24: Optohead (IR to Bluetooth) .....	30
Fig. 25: Connecting the optohead in the holding cover to the meter.....	30
Fig. 26: Optohead fitted on the meter. Display lid is in a 90° angle to the meter display.....	30
Fig. 27: Removal of optohead cover by pushing back display lid.....	31
Fig. 28: Breaking of communication seal and lifting of module lid .....	32
Fig. 29: Exchanging protective cover in order to add a new module .....	32
Fig. 30: Inserting module, pushing it into place and closing the module lid .....	33

## List of tables

Table 1: Dimensions of sonico® EDGE meters.....	12
Table 2: Recommended torque values .....	22
Table 3: Symbols of the sonico® display .....	25
Table 4: Connection schematics communication modules.....	33
Table 5: Error types and codes and their standard thresholds .....	34
Table 6: Metrological data of sonico® EDGE flow meters .....	36

# 1. General information

This user manual provides all necessary information for the smooth and safe operation of the **sonico® EDGE flow meter**. It contains important information on product identification, storage, installation, commissioning, operation, maintenance and disposal of the device. Before putting the device into operation, read this user manual carefully. To prevent possible injuries to the user and damage, use the device only for the intended use described below in chapter 2.2. Always keep this document handy in the vicinity of the device! If you do not understand the contents of this document, contact the manufacturer. In no case may GWF AG be held reliable for any damage or injury caused by misunderstanding of the information.

## 1.1. Data protection and security

GWF AG will not be responsible for any loss of data resulting from the use or misuse of this or any other GWF AG product. Data security is given by login with username and password. Please be advised that there are inherent security risks in transmitting data via the internet. It is not possible to safeguard completely against unauthorized access by third parties.

## 1.2. Liability





In case of inappropriate or unintended use, no liability for the proper function of the device can be assumed. Improper installation and operation of the device will cause the warranty to be void. GWF AG has made every effort to ensure the accuracy of the contents of this manual and the software. However, GWF AG can offer no guarantee that the information provided is accurate and/or free of error. The information provided in this manual is subject to change without notice at any time. GWF AG reserves the right to alter designs, layouts or software without prior notification and will not be liable in any way for possible consequences of such changes.

## 1.3. EU Conformity declaration

The manufacturer GWF hereby declares that this product complies with Directive 2014/30/EU, 2014/35/EU, 2014/53/EU, 2011/65/EU. The full text of the EU declaration of conformity can be found in section chapter 15.3 at the end of this documentation.

## 1.4. Warnings and safety symbols

Depending on the hazard level, warnings are displayed according to ISO 3864-2 as follows.

 <b>DANGER</b>	<b>High level of risk.</b> Indicates a potentially or imminently hazardous situation which, if not avoided, will result in death or serious injury. Please always consult the Manual, if this signs appears or is shown.
 <b>WARNING</b>	<b>Medium level of risk.</b> Indicates a potentially or imminently hazardous situation which, if not avoided, could result in death or serious injury. Please always consult the Manual, if this signs appears or is shown.
 <b>CAUTION</b>	<b>Low level of risk.</b> Indicates a potentially hazardous situation that may result in minor or moderate injury or damage. Please always consult the Manual, if this signs appears or is shown.
 <b>Notice!</b>	Important handling instruction. Indicates a situation which, if not avoided, may cause damage to the device. Information that requires special emphasis.
 <b>Information!</b>	This symbol indicates helpful notes and information for handling the device.

## 1.5. Trademarks

All terms and brand names used in the manual are generally subject to the trademark and patent protection of the respective companies.

## 2. General safety instructions



### Notice!

Follow the safety instructions generally and at any time. The notes and warnings will not be shown for each chapter of the manual again.

### 2.1. Requirements for the personnel

Transport, installation, electrical connections, commissioning, operation and maintenance of the device must be carried out by qualified and authorized personnel.

Personal injuries and serious damage to the device are caused by insufficiently qualified personnel.

#### Qualified personnel:

- Persons, who, through their professional training and education, are familiar with the safety guidelines of electrical and automation engineering.
- Persons, who, as project, commissioning, and installation personnel, are authorized to commission, ground and label circuits and devices/systems in accordance with the standards of safety engineering.
- Must be able to safely assess the results of their work and must be familiar with the contents of these operating instructions.

#### Authorized personnel:

- Persons who are intended to work on the basis of legal regulations or have been approved by the manufacturer for certain activities.

#### The following requirements must be met:

- The user manual must be read carefully and fully understood by qualified personnel. Instructions must be followed.
- Qualified personnel must be authorized by the plant operator.
- At the installation location the required personal protective equipment must always be worn.
- All applicable national standards, safety requirements and accident prevention regulation must be observed.

### 2.2. Intended use



### WARNING

Improper use can seriously compromise the safety of the device. The device is exclusively designed to be used for purposes as described below.

Keep within the specified pressure and temperature range while using the device.



### Information!

The manufacturer is not liable for any damage resulting from improper use or use for other than the intended purpose.

The ultrasonic flow meter **sonico® EDGE** is designed for measurement of flow velocity and net volume flow of clean cold water in fully filled pipes.

The meter is only intended for use within the technical limit values specified in chapter 15.1 of this manual or in the data sheets.

### 2.3. Operational safety

Only operate the device when it is in a technically perfect and safe operating condition. The operator is responsible for the safe operation of the product.

### 2.4. Product safety

This measuring device is designed in accordance with good engineering practice to meet state-of-the-art safety requirements. It has been tested and left the factory in a condition in which it is safe to operate. It meets general safety standards and legal requirements. It also complies with the EU directives listed in the device-specific EU Declaration of Conformity.

## 2.5. Electrical safety

### Lithium-ion back-up battery

This product contains a lithium-ion back-up battery. Incorrect use or operation of the battery may result in potentially serious hazards.

Only batteries approved by GWF may be installed within sonico® EDGE devices. Repairs and replacements are only to be done by trained GWF professionals.

Do not expose the meter to temperatures above 70 °C.

Do not ship or transport sonico® EDGE unless the following instructions are followed:

The built-in lithium-ion batteries are classified as 'category UN3481 PI 967 Sec II'. The transport of devices containing such batteries must conform to the applicable rules specific to the means of transport used. Regulations on packing, identification and accompanying documents must be followed. The carrier must always be informed of the contents. A suitable warning label according to 'UN3481 PI 967 Sec II' must be attached to the packing and remain visible on the outside of the package.

Do not dispose of depleted or partially depleted batteries. Batteries must be transported and recycled conforming to local regulations. According to European regulations (EU Directive 2012/19/EU), European old or end-of-life equipment may be returned to the manufacturer for disposal or recycling.

Damaged, leaking or overheated batteries must be handled by a specialist. All personnel must immediately be evacuated from the area and professional assistance must be provided.

### WARNING

### DANGER

#### Dangerous contact voltages

- Risk of electric shock! Touching live parts is fatal, causes death or serious injury.

#### Disconnect device

- Do not install or wire the device while it is connected to the power supply.
- The system has no on / off switch. It is therefore imperative to attach the system to an additional circuit breaker (at least 2 A for AC or 5 A for DC) to disconnect the system from the power supply in the event of a fault or repair. The circuit breaker should be near the transmitter.
- After switching the power off there still could be electric loads which are stored in the construction groups inside the instruments.

### WARNING

#### Connecting device

- The electrical connection must be carried out by a certified electrician. Improper connection can cause injury or death.
- Observe the national regulations for electrical installations! By handling products, which are supplied by electrical voltage, the valid IEC instructions, especially IEC 60364, IEC 61558, IEC 60335, IEC 60598-1 and IEC 60065 must be observed.
- It is necessary to connect the system to an external overvoltage protection device.
- Parts or construction groups must only be set into operation in case they are built into a housing and protected against touching.
- Conducting cables or conductors which are connected to the instrument, parts or construction group, must be checked regularly for isolation faults or sites of fractures. If a fault is found in the supply line the instrument must be switched off immediately till the defective line has been replaced.

### WARNING

### Protective grounding

- Protective grounding:  
Suitable measures for protecting people from the effects of short circuits to earth and ground faults must be carried out. The conductive system parts must be connected to a suitable earthing conductor via the PE conductor.
- Electrostatic discharge:  
Electronic components can be destroyed by electrostatic discharge during installation. Avoid high electrostatic charges by suitable grounding measures.
- The functional earthing is not identical to the protective earthing according to DIN VDE 0100!
- EMC ground connectors only fulfil secondary measures for protection against dangerous contact voltages.
- The green-yellow wires of the protective conductor (PE) fulfil the measures for protection against dangerous contact voltages, but not the requirements of EMC Directive 2014/30/EU.
- When earthing a system, take appropriate protective and functional measures in accordance with DIN VDE 0100 and EMC Directive 2014/30/EU.

 **WARNING**

 **DANGER**

 **CAUTION**

 **WARNING**

Please always consult the Manual, if this signs appears or is shown

Symbols	Description
	<b>Protective conductor connection</b> This symbol refers to the protective conductor connection of the device. Depending on the type of installation, the device may only be operated with a suitable protective conductor connection in accordance with the applicable laws and regulations.
L	Line conductor
N	Neutral conductor

## 2.6. IT security

Warranties are valid only if the device is installed and used as described in this manual. Security mechanisms are implemented in sonico® EDGE to prevent crucial settings from tampering or inadvertent changes as according to WELMEC 7.2.

Additional IT security measures for the device and data transfer must be implemented by the operators themselves according to their security standards.

### 3. Product Description

Sonico® EDGE is an externally powered precision flow meter suitable for flow measurement of cold water in fully filled pipes. Its measurement method is based on the ultrasonic time of flight principle. Due to its advanced signal processing applying the methods of Time Reversed Acoustics, sonico® EDGE is known as a GWF 4D technology® product.

#### 3.1. Product dimensions

- Sonico® EDGE is available as a compact version. The signal converter including the display is directly mounted onto the meter body. The meter head can be equipped with up to three independent external Near Field Communication (NFC) modules.
- Nominal sizes are DN 50, 80, 100, 150, 200 & 300.
- Other nominal sizes and lengths on request.

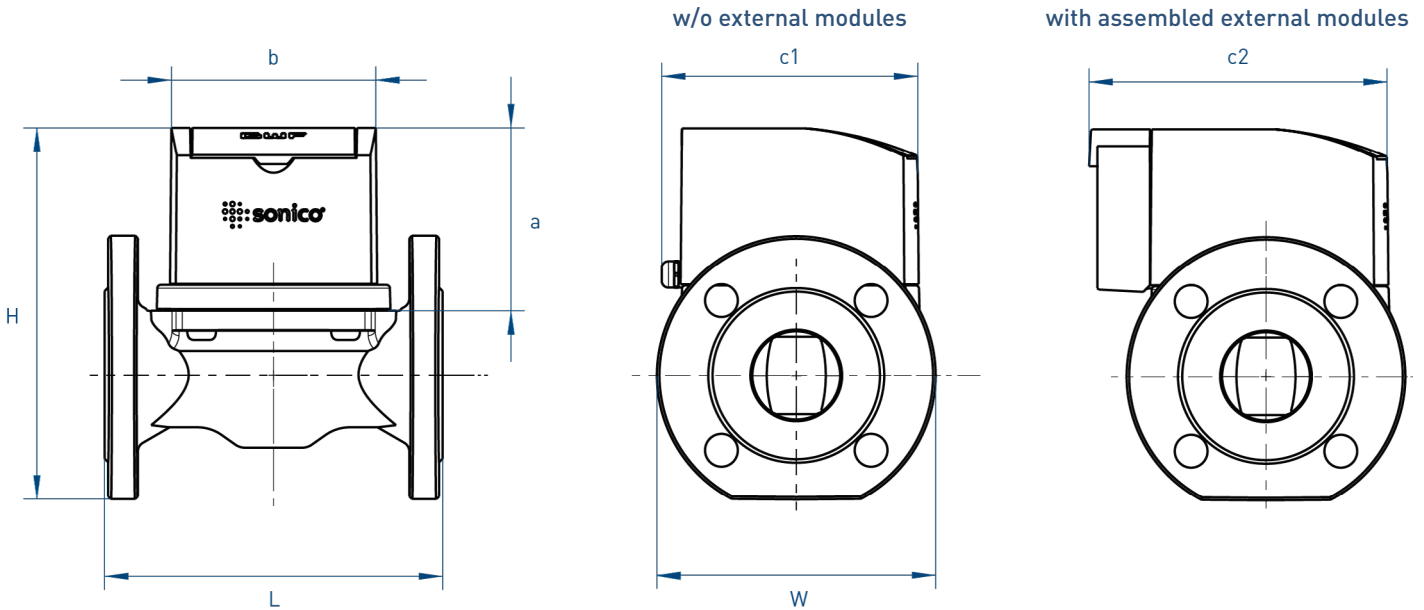

Fig. 1: Dimensions of sonico® EDGE with (right) and without (middle) external NFC modules

Nominal size		L	H	W	a	b	c1	c2	Weight [kg]
mm	inch	(mm)	(mm)	(mm)	(mm)	(mm)	(mm)	(mm)	
50	2	200	220	165	110	122	152	177	13
65	1.5	200	236	185	153	122	152	177	14
80	3	200	250	200	110	122	152	177	16
100	4	250	270	220	110	122	152	177	21
125	5	250	285	250	169	122	152	177	25
150	6	300	336	285	120	122	152	177	33
200	8	350	395	340	234	122	152	177	60
250	10	450	425	410	241	122	152	177	82
300	12	500	475	460	252	122	152	177	115

Table 1: Dimensions of sonico® EDGE meters

### 3.2. Product design

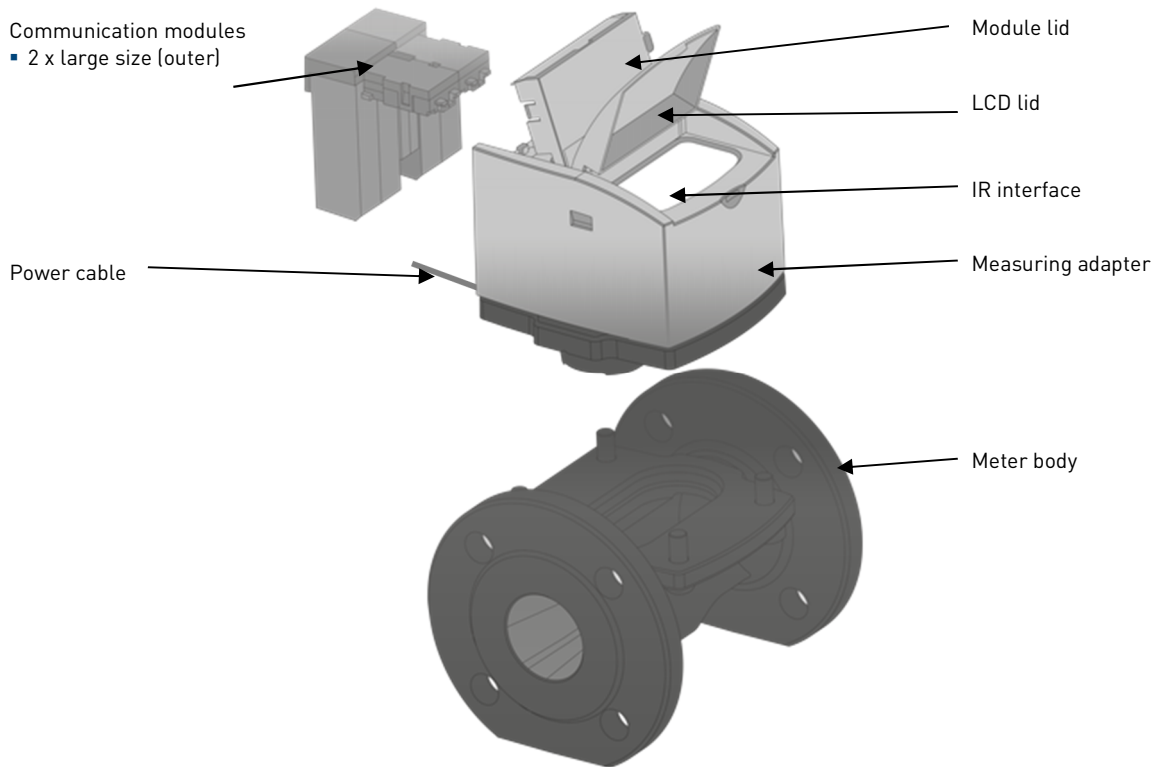

Fig. 2: Parts of the sonico® EDGE

### 3.3. Seals

Three seals are placed on sonico® EDGE in order to protect it from tampering:

- The cap of the meter head acts as a seal protecting all electronics from manipulation. Breaking this seal invalidates any warranty or metrological certification.

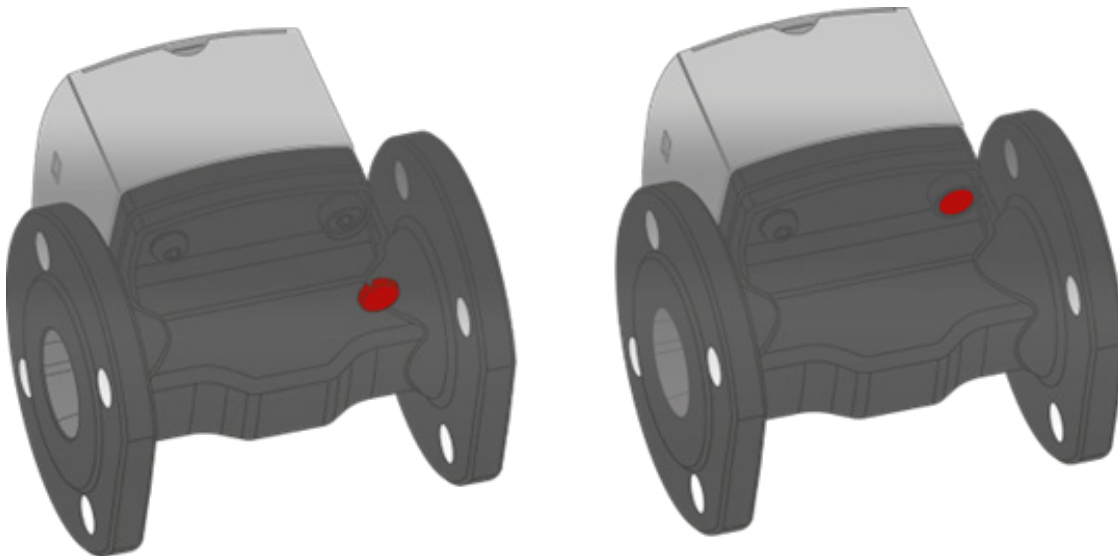

Fig. 3: Calibration seal

- The cap of the meter head acts as a seal protecting all electronics from manipulation. Breaking this seal invalidates any warranty or metrological certification.

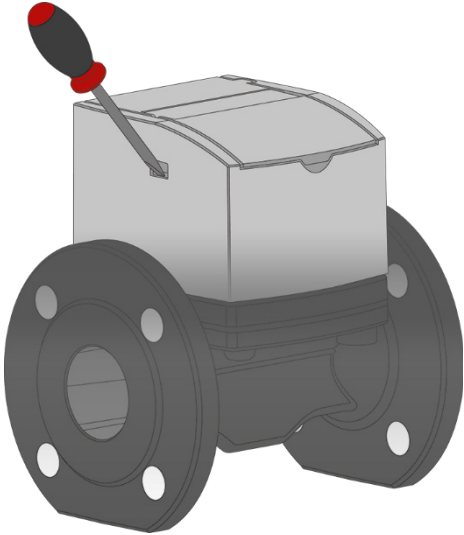

Fig. 4: Meter cap as seal for electronics

- Communication seal on the communication module lid. Can be removed in order to attach or exchange communication modules (see chapter 12.1).

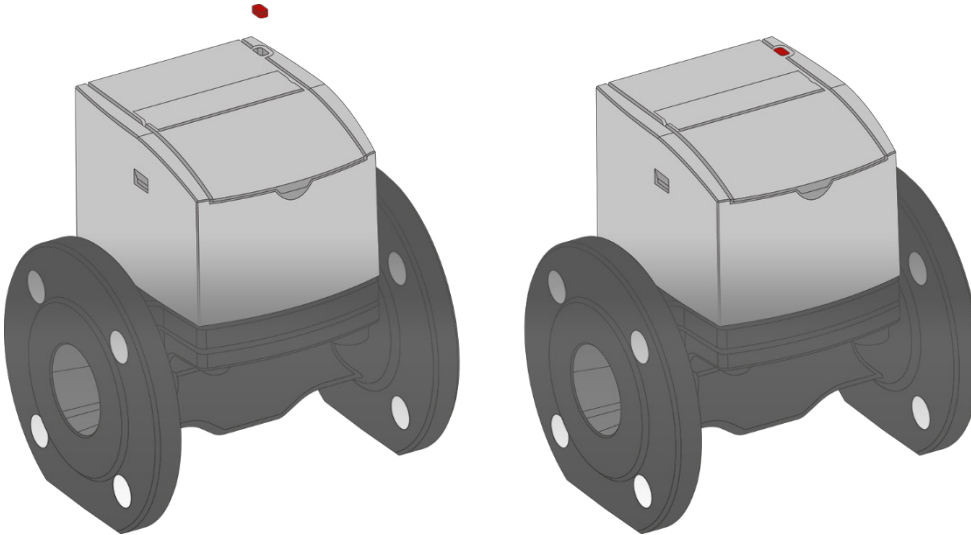

Fig. 5: Communication seal for modules

### 3.4. Applications

- Potable and raw water
- Water production and water supply, zone metering
- Irrigation
- Industrial flows (flow measurement, process optimization)

### 3.5. 4D technology®

The 4D technology® signal processing is based on the patented Time Reversed Acoustic (TRA) ultrasonic technology and is characterized by a high signal-to-noise ratio.

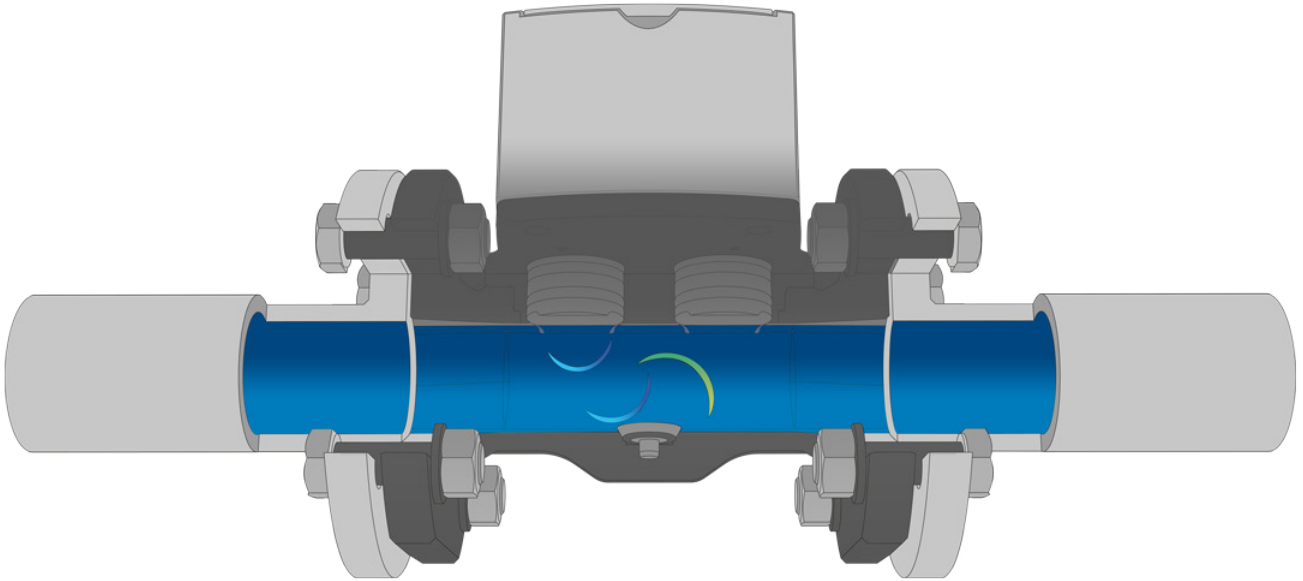

Fig. 6: Illustration of time of flight measurement principle

- Every single device is taught in standing water on the test bench.
- In standing water, the semi-dry transducers send an ultrasonic pulse through two paths and measure the resulting base signal:

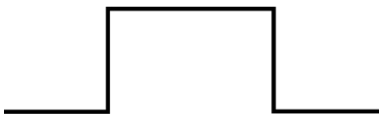

Fig. 7: Ultrasonic pulse sent in standing water

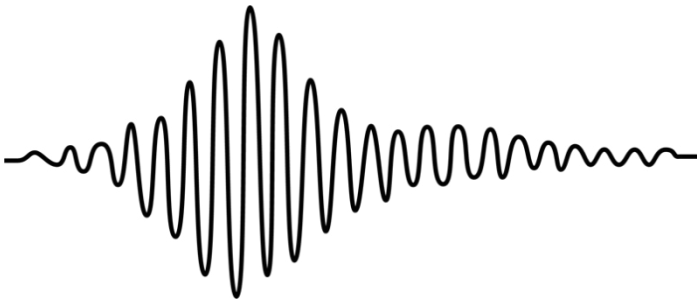

Fig. 8: Meter-specific base signal received in standing water

- The base signal is inverted and saved in the microcontroller:

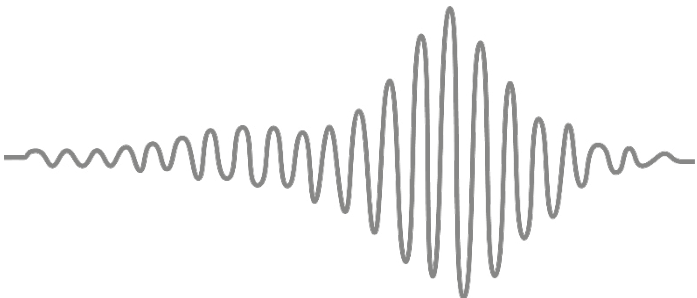

Fig. 9: Time-reversed base signal forms the TRA reference signal

- This is how the TRA reference signal is created. It is made up of a signal as well as a single pulse and is similar to a melody.
- The TRA reference signal gives each meter its own DNA, which takes the material and assembly tolerances into account:

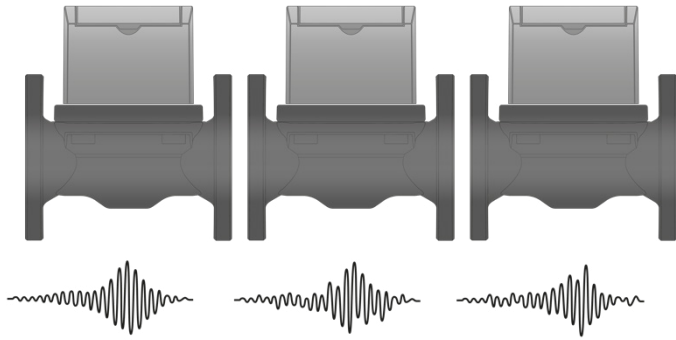

Fig. 10: Every sonico® EDGE meter has an individual TRA signal

- During operation, the reference signal is sent and received in the flow and reverse flow direction.
- The two signals are now overlapped by digital means.
- The unique shape of the signal simplifies the detection of the amplitudes with respective timing in both directions.
- This enables the time shift of the two maximum amplitudes to be determined and the flow velocity and flow rate to be calculated.

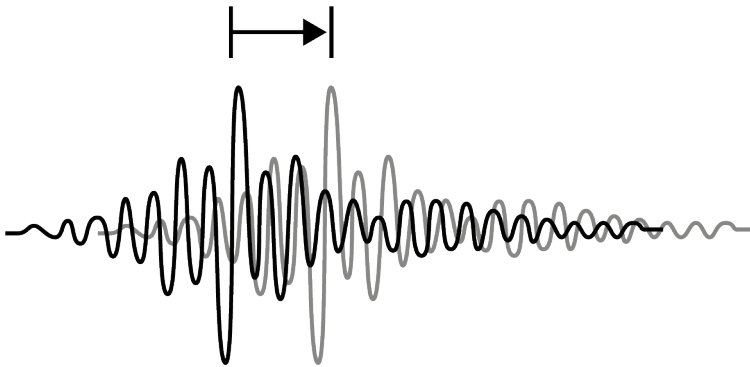

Fig. 11: The reference signals received with and against flow direction are overlapped

- Flow profile distortions are detected and compensated.

## 4. Incoming inspection

### 4.1. Scope of delivery

#### Notice!



Inspect the packaging and the contents for damage or signs of rough handling. Report damage to the carrier and to the local office of the manufacturer. Check that the delivery is complete and agrees with the shipping documents and your order. If damages occurred or any items are missing, please contact GWF without delay and before proceeding with installation.

#### Scope of delivery

1. Sonico® EDGE flow meter
2. IP68 power cable connection included
3. Communication modules attached to the meter, depending on the order
4. Short installation guide
5. One pair of flange gaskets

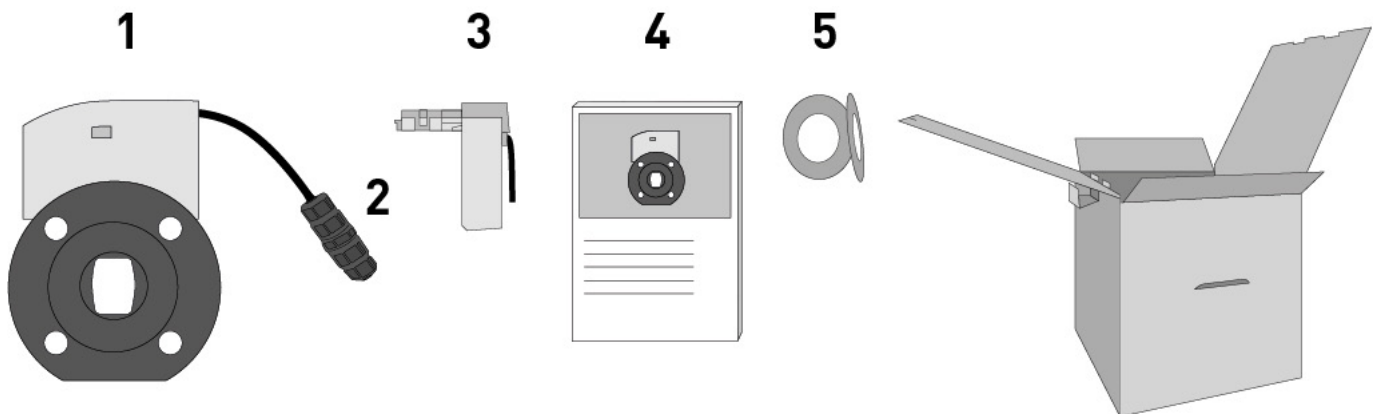

Fig. 12: Scope of delivery



#### Information!

Keep original packaging for safe storage and transport.

#### Optional accessories

1. IR communication kit
  - a) Optohead holder
  - b) Optohead (optical communication device)
  - c) Charging cable for optohead

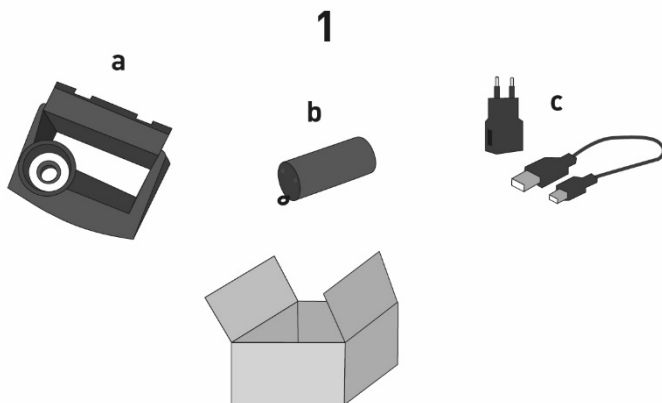

Fig. 13: Optional accessories



### Information!

Assembly materials and tools are not part of this delivery.

## 4.2. Checklist incoming acceptance

See chapter 17.1.1.



### Information!

If one of the points in the checklist are not satisfied, please contact GWF. The full technical documentation and manual are available online on [www.gwf.ch](http://www.gwf.ch).

## 4.3. Nameplate



### Information!

Check the name plate to ensure that the device is delivered according to your order. You can do so by verifying serial number and version number on the name plate. Additionally, check for the correct supply voltage on the name plate.

The name plate (Fig. 14) indicates important data for identification of the device.

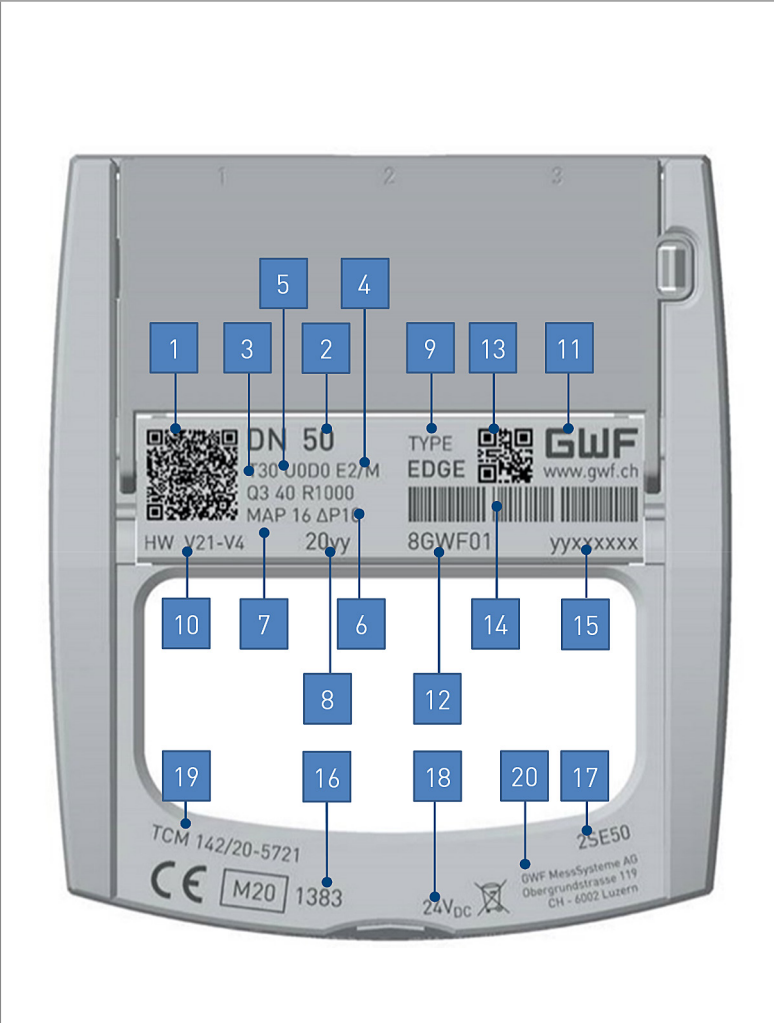

1	GWF QR code
2	Nominal diameter
3	Temperature class
4	Environmental class
5	Installation condition
6	Permanent flow rate and R ( $Q_3/Q_1$ )
7	Max. admissible pressure and pressure loss class
8	Year of production
9	Meter type
10	Hardware number
11	Manufacturer and website
12	Manufacturer postfix
13	2D code for postfix
14	1D barcode for postfix
15	Serial number
16	Certification information
17	Order variant number
18	Power supply information
19	Notified body
20	Postal address GWF

Fig. 14: Exemplary name plate (DN 50 meter)

## 5. Storage / Transport

### 5.1. Storage

- Store the equipment in a dry and dust-free place.
- Do not store outdoors.
- It is recommended to avoid continuous exposure to direct sunlight.
- Store the device in its original packaging.
- Storage temperature: -25...+70 °C, ideally at 20 °C.

### 5.2. Transport

#### **WARNING**

#### **Warning – Bodily injury**

Life-threatening danger due to suspended loads possibly falling.

Remaining under suspended loads is prohibited.

#### **WARNING**

#### **Warning – Risk of injury due to the sensor slipping**

The meter's center of gravity may be higher than the harness' suspension points.

- Make sure that the sensor does not slip or turn during transport.
- Support the sensor laterally during transport.

- Do not lift the device by the attached communication modules.
- Do not lift the device by the display lid.
- Do not use lifting chains, only lifting straps wrapped around both meter body flanges.
- Do not lift the meter lopsided by one flange only.

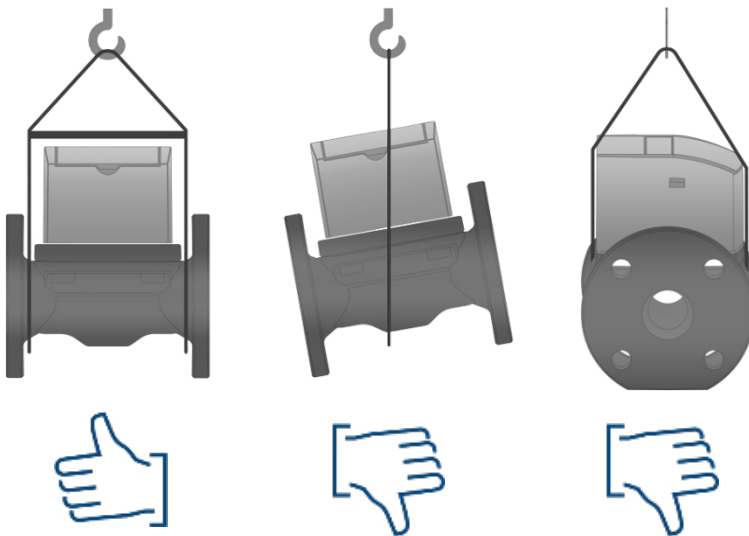

Fig. 15: Lifting instructions

### 5.3. Packaging disposal

All packaging materials are environmentally friendly and 100 % recyclable.

- Packaging: cardboard box in accordance with European packaging guideline 94/62EC, recyclability confirmed by RESY symbol.

## 6. Installation / Mounting

### Notice!



Be advised that possible mounting and connection errors and their effects are beyond our control. Therefore, the manufacturer cannot be held responsible for damages as a result of incorrect handling, installation, and maintenance of the equipment.

### 6.1. General requirements

The meter must be installed by a trained and instructed worker. Thereby the recognized standards of good practice must be respected (Refer to the instructions given in ISO 4064-5:2014).

The meters must be stored in a dry, cold, dust and germs free environment. Make sure that during the installation procedure all hygienic standards and recommendations are followed.

### 6.2. Installation conditions

- The meters' metrological performance depends on flow direction and meter orientation. Orientation can be selected to best suit the installation conditions.
- The flow direction is determined during production. The corresponding arrow is shown on the display after the power supply is connected and must be taken into account during installation. Gaskets must not protrude into the pipeline or be misaligned.
- All meter settings and functions will be automatically and correctly activated once the measurement channel is completely filled with water.

Open feed or discharge may cause air in measuring channel:

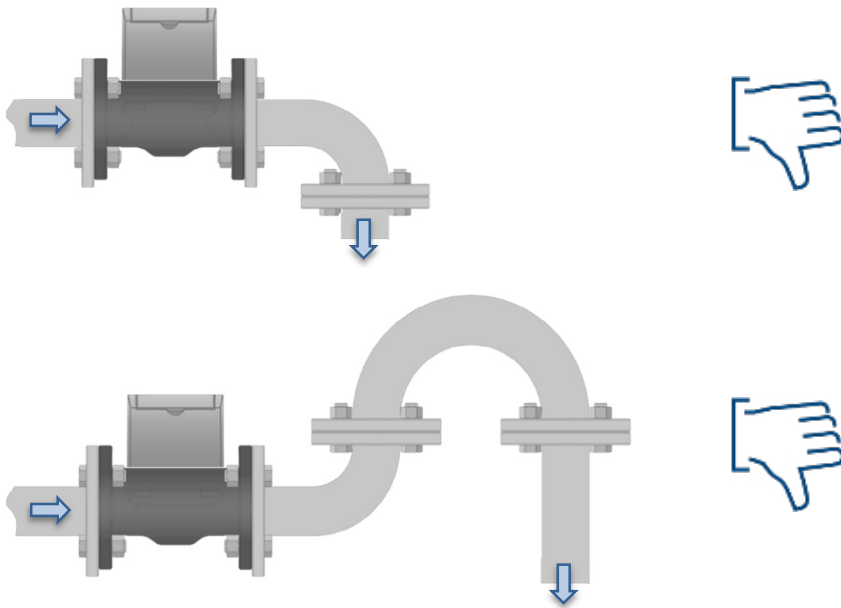

- The meter does not need any straight inlet or outlet pipe sections, even with 90° bends or valves present.
- The meter must always be filled with water. Air in the pipe will result in an error.

Elbows (caution, measuring channel must not contain air):

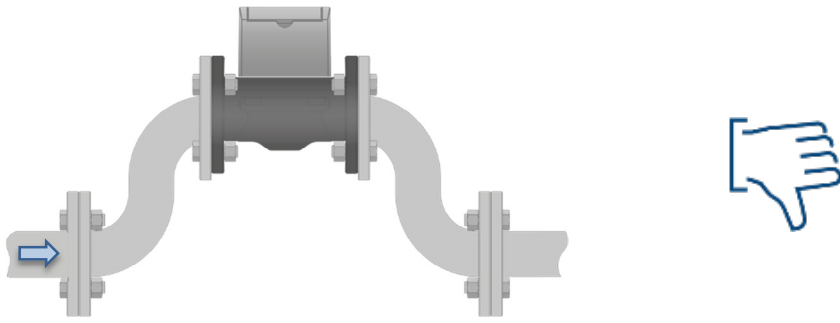

Valves:

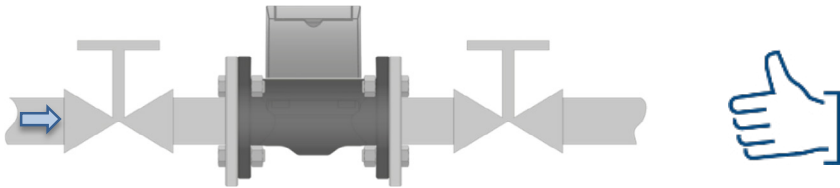

Pumps:

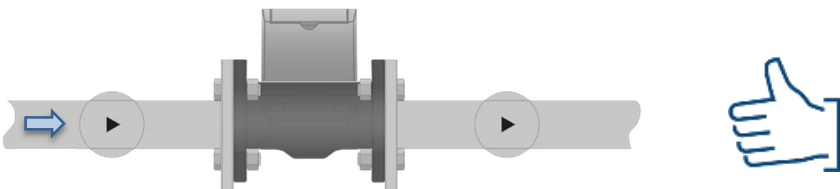

Mounting position independent of meter orientation:

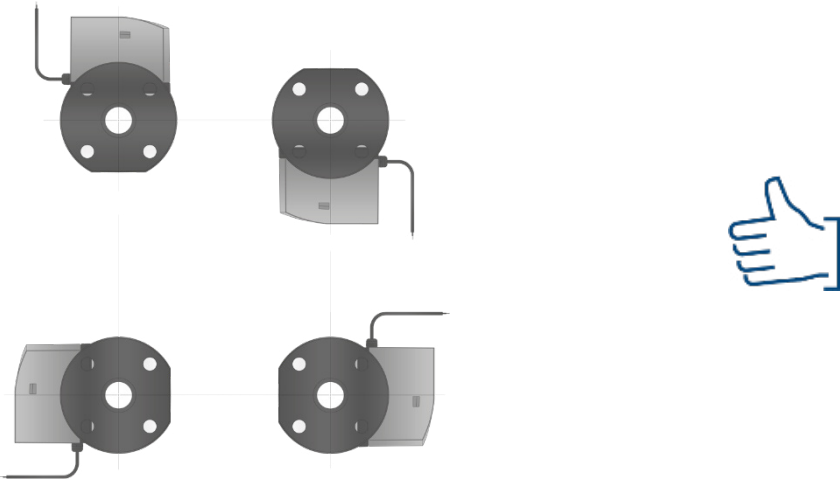

### 6.3. Environment and process requirements

- For correct flow measurements, the meter should always be filled with water. Non-wetted sensors show loss of signal. Although this will not cause damage to the meter, the meter will not measure flow and display the empty pipe alarm.
- It is recommended to protect the meter from direct sunlight. It is recommended to keep the lid closed.
- Operating temperature of medium. Depending on meter type: T30 = 0.1 to +30 °C, T50 = 0.1 to +50 °C. Temperature class indicated on the nameplate, see Fig. 14.
- The environmental temperature must be within -25 °C and 70 °C.
- Pressure: Please ensure that the meter strictly operates within the pressure rating printed on the nameplate (Fig. 14).
- Sonico® EDGE is classified according to 2014/32/EU (MID) in the mechanical environment class M2 (significant or high levels of vibration and shock) and in the electromagnetic environment class E2.

## 6.4. Checklist installation preparation

See chapter 17.1.2.

## 6.5. Mounting



### Notice!

Please take care to use the proper gasket to prevent damaging the liner of the flow meter. In general, the use of spiral wound gaskets is not advised, as it could severely damage the liner of the flow meter.

**Step 1:** Remove the meter from the packaging.

**Step 2:** Install the meter according to the most suitable LCD orientation and tightening the bolts as indicated in chapter 6.5.1

### 6.5.1. Torques and pressures

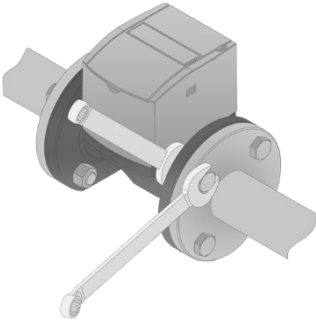

Fig. 16: Schematic illustration of bolt tightening to flanges

#### Tightening of bolts:

- Always tighten the bolts uniformly and in diagonally opposite sequence.
- Do not exceed the maximum torque value.
- **Step 1:** Apply approx. 50 % of max. torque given in Table 2.
- **Step 2:** Apply approx. 80 % of max. torque given in Table 2.
- **Step 3:** Apply 100 % of max. torque given in Table 2.

Recommended torque values are shown in Table 2. Parameters strongly depend on type of bolt and amount of grease used.

DN (mm)	PN 16	
	Nm	ft-lbs
50	120	90
65	120	90
80	120	90
100	120	90
125	120	90
150	250	180
200	250	180
250	250	180
300	250	180

Table 2: Recommended torque values

## 7. Electrical connection



### DANGER

#### Dangerous contact voltages

- Risk of electric shock! Touching live parts is fatal, causes death or serious injury.



### WARNING

#### Disconnect device

- Do not install or wire the device while it is connected to the power supply.
- The system has no on / off switch. It is therefore imperative to attach the system to an additional circuit breaker (at least 2 A for AC or 5 A for DC) to disconnect the system from the power supply in the event of a fault or repair. The circuit breaker should be near the transmitter.
- After switching the power off there still could be electric loads which are stored in the construction groups inside the instruments.



### WARNING

#### Connecting device

- The electrical connection must be carried out by a certified electrician. Improper connection can cause injury or death.
- Observe the national regulations for electrical installations! By handling products, which are supplied by electrical voltage, the valid IEC instructions, especially IEC 60364, IEC 61558, IEC 60335, IEC 60598-1 and IEC 60065 must be observed.
- It is necessary to connect the system to an external overvoltage protection device.
- Parts or construction groups must only be set into operation in case they are built into a housing and protected against touching.
- Conducting cables or conductors which are connected to the instrument, parts or construction group, must be checked regularly for isolation faults or sites of fractures. If a fault is found in the supply line the instrument must be switched off immediately till the defective line has been replaced.



### WARNING

#### Protective grounding

- Protective grounding:  
Suitable measures for protecting people from the effects of short circuits to earth and ground faults must be carried out. The conductive system parts must be connected to a suitable earthing conductor via the PE conductor.
- Electrostatic discharge:  
Electronic components can be destroyed by electrostatic discharge during installation. Avoid high electrostatic charges by suitable grounding measures.
- The functional earthing is not identical to the protective earthing according to DIN VDE 0100!
- EMC ground connectors only fulfil secondary measures for protection against dangerous contact voltages.
- The green-yellow wires of the protective conductor (PE) fulfil the measures for protection against dangerous contact voltages, but not the requirements of EMC Directive 2014/30/EU.
- When earthing a system, take appropriate protective and functional measures in accordance with DIN VDE 0100 and EMC Directive 2014/30/EU.



### DANGER



### CAUTION



### WARNING

Please always consult the Manual, if this signs appears or is shown

## 7.1. Checklist electrical connection: tools and requirements

See chapter 17.1.3.

## 7.2. Power supply meter

### Caution



- Before connecting or disconnecting the cable, be sure the power is switched off.
- All cables must be installed in order to protect cables from mechanical destruction. Mount the cables firmly to the wall, without any loops and cross-overs and in sufficient distance to moving parts to avoid accidents caused by stumbling.

Voltage supply: 9 - 36 V DC  $\pm 10\%$  (26.4 V)

$I_{\text{supply}} @ 24 \text{ V DC}$ : 100...300 mA whilst the internal accumulator is being charged

$I_{\text{supply}} @ 24 \text{ V DC}$ : 20...50 mA once the internal accumulator is fully charged

### 7.2.1. Technical specification for power transformer

Min. voltage output/-current: 24 V/200 mA

Max. allowed ripple: 200 mV peak-peak

### 7.2.2. Power cable and joint connection

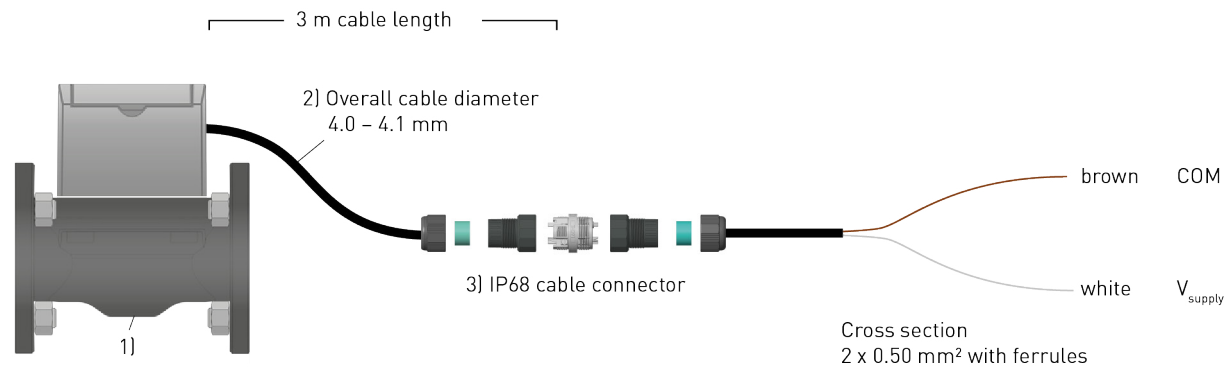

1	Sonico® EDGE water meter
2	External power supply cable [3 m]
3	IP68 cable connector

Fig. 17: Electrical connection scheme and part list of sonico® EDGE meter power supply

3 m of power cable are connected to the sonico® EDGE measuring adapter upon delivery. Make sure to provide suitable additional length of cable and connect via the included IP68 cable connection.



### Warning

The user is responsible for ensuring EMC Protection for any electrical components connected to the meter that were not included in the scope of delivery.

## 7.3. Checklist electrical connection: final inspection

See chapter 17.1.4.

## 8. Display and meter activation

### 8.1. Display symbols

Sonico® EDGE is equipped with an integrated LCD showing several symbols and two number fields. The larger segment on top of the display is a 10-digit field and the smaller one on the bottom of the display is a 7-digit field.

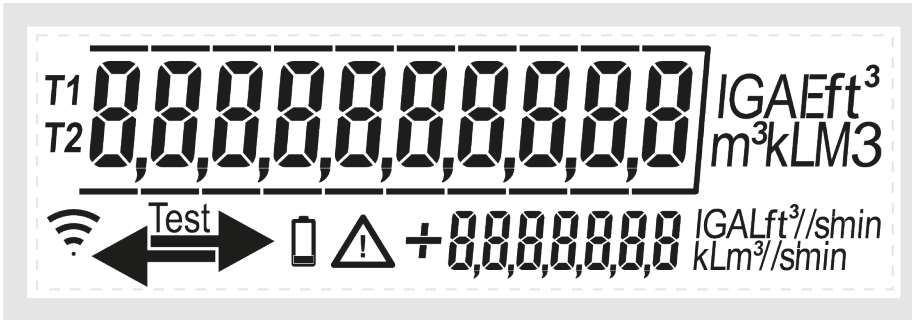

Fig. 18: Scheme of all segments visible on sonico® EDGE display

Location of information in normal operating mode:

- The upper, 10-digit field depicts the total volume.
- The lower, 7-digit field shows the current flowrate.
- The + sign in front of the flowrate indicates flow in forward direction with respect to the defined forward direction.
- The defined direction is shown by the arrow in the bottom left part of the display.





Symbol	Meaning
<b>T1</b>	Tariff zone 1
<b>T2</b>	Tariff zone 2
<b>Test</b>	Meter test bench mode
	Alarm flag, error occurred
	Radio interface connected (not activated yet)
	Arrow indicates the defined flow direction
	No external power supply

Table 3: Symbols of the sonico® display

All LCD units, i.e. volume and flow units, can be configured by GWF according to the specific order.

As a standard factory setting, three decimals are shown for volume in the larger 10-digit display field, as shown in Fig. 19.

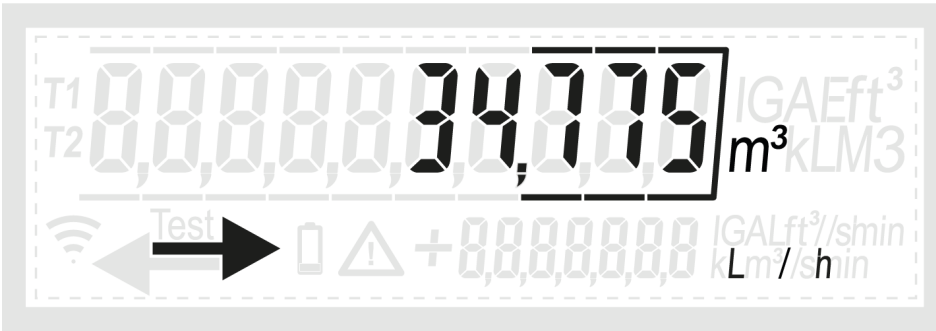

Fig. 19: Standard display of volume with three decimals

## 8.2. Meter activation

After connecting the meter to an external power supply, sonico® EDGE is ready for activation and measurement.

### Step 1: Check meter display

In a dry pipe, the meter will display the following information:

- Latest measured total volume in the volume field.
- The alarm flag (indicating an empty pipe).
- Periodically, the error code "Air in pipe" E\_L0001 will be display in the lower 7-digit field.

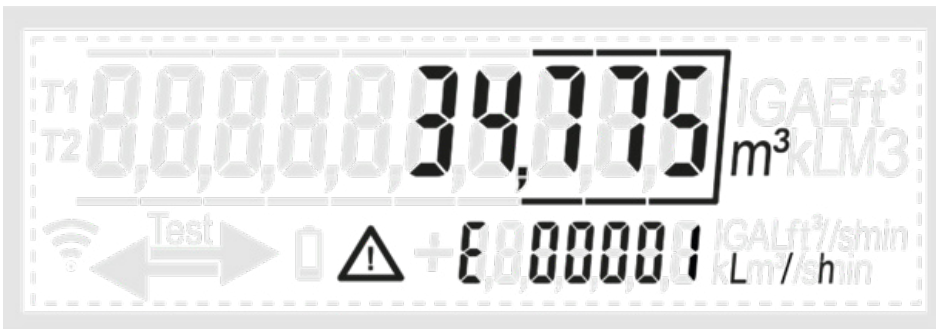

Fig. 20: Empty pipe warning appears during installation of the meter

### Step 2: Fill the pipe with water

Once successfully installed, open the upstream valve to fill the pipe. The alarm flag shown in the display disappears as soon as the meter detects water.

### Step 3: Flow direction

To activate the "flow direction arrow", a flowrate above the configurable cut-off flowrate value (e.g. 25 l/h) must be detected for at least 10 measurement cycles (approx. 5 s). Afterwards, the measured flow direction is automatically set as the forward flowrate direction. The arrow direction is set and stored permanently. If activated in the meter settings (standard factory settings), any flow in the opposite direction will be counted as reverse volume.



### Information!

The meter does not register the volume if the averaged flow rate is below its cut-off flow rate (see chapter 15.1).

After a flow has been measured by the device, advanced analytical functions such as data logging and leak detection become active and are assigned to the respective data fields.

## 8.3. Default display sequence

When the meter is running, the following reoccurring sequence in the display will be shown:

1. Cumulative volume in the upper number field and current flowrate in the lower number field (min. 30 s)
2. All segments on, i.e. all symbols lit up as shown in Schematic illustration of bolt tightening to flanges (min. 1 s)
3. All segments off, i.e. blank display (min. 1 s)
4. Forward volume in the upper number field as shown Fig. 21.
5. Reverse volume in the upper number field as shown Exemplary screenshot of forward flow volume register as shown in display sequence.

6. If an error occurred: Warning symbol and error code starting with the letter "E" in the lower number field (min. 1 s). Error codes are described in chapter 13. An example of the error message for an empty pipe is shown in Fig. 20.



Fig. 21: Exemplary screenshot of forward flow volume register as shown in display sequence



Fig. 22: Exemplary screenshot of back flow volume register as shown in display sequence

In addition to the default display sequence, the firmware checksums and versions are periodically displayed. Sonico® EDGE incorporates two firmware parts, one for metrological characteristics, the other for LCD. Every 5 min. the checksum and version of first the metrological firmware and then the LCD firmware are displayed.

The checksum is shown in the upper number field; the version number is displayed in the lower number field. The version number will be presented in 4 digits, e.g. firmware version 2.0 will be presented as 0200 and version 2.47 as 0247.

## 8.4. Test bench mode

For calibration and verification measurements, the sonico® water meter can be set into test bench mode using sonico® LIFE application software. The activation of the test bench mode is password protected.

As soon as the test bench mode is activated, "Test" is shown in the display. The volume register shows one more decimal, thus 0.1 l resolution by default. The test bench mode can be set back to operation or other modes manually using the sonico® application software.

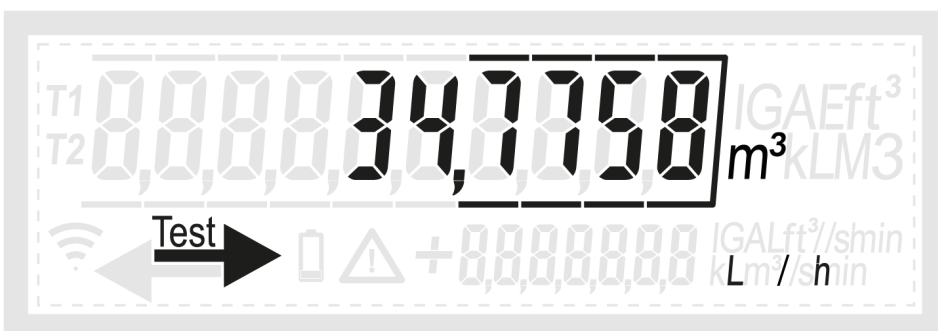

Fig. 23: Example of display during activated test bench mode.

## 9. Internal data logger

### 9.1. Access and activation

All stored data can be retrieved on demand, but only through the device's IR (infrared) interface.

Users can delete all datalogger data when needed. However, data deletion is only possible via the IR interface.



#### Information!

If the device's real-time clock (RTC) is changed, all datalogger data will be erased automatically.

The datalogger must be manually started and stopped by the user. These operations are also only available via the IR interface.

The datalogger records data at regular time intervals, which can be configured by the user. By default, the logging interval is set to 1440 minutes (24 hours). The interval can be adjusted to any value between 1 minute and 43'200 minutes (30 days). For each log entry, the system records both the start and end time of the logging period. If the logging interval is changed during operation, the remaining time from the previous interval continues to count toward the next entry.

Example: If the interval was 1 minute and 30 seconds have passed when it is changed to 2 minutes, the next log will occur in 1 minute and 30 seconds.

### 9.2. Data logger content per entry

Each datalogger entry includes the following types of data:

- Forward volume
- Reverse volume
- Cumulative volume (measured between two intervals)
- Max/min water temperature
- Max/min ambient temperature
- Flow rate
- COM (communication) alarms
- MET (measurement) alarms

Note: Each min/max value includes the exact time when it occurred.

### 9.3. Data storage capacity

The datalogger can store a minimum of 3840 entries, which corresponds to 40 days of data at a 15-minute logging interval. The storage space is limited, and when full, the system will automatically overwrite the oldest data (FIFO – First In, First Out).

### 9.4. Data logger retrieval

Users can retrieve datalogger entries one at a time. Each entry includes the full set of logged data as described above. Entries are accessed using a relative history index (e.g., most recent entry, second-most recent, etc.). Every data retrieval also includes information on the total number of available entries in memory.



#### Information!

All interactions with the datalogger—starting, stopping, reading data, clearing memory, or changing the logging interval—must be done exclusively through the IR interface. This ensures secure and controlled access.

## 10. Tariff

### 10.1. Tariff volumes general

This section explains how tariff volumes (T1 and T2) function, how to configure them, and under what conditions they are updated. Tariff volumes are not legally relevant under WELMEC standards.

Tariff volumes T1 and T2 are updated in sync with normal volume updates. Configuration settings related to tariff volumes are not legally relevant. Tariff volumes can be enabled only via the IR interface, but they are disabled by default.

### 10.2. Operating modes

Two sets of T1 and T2 values exist:

- One for Operation/Testbench Mode
- One for Simulation Mode

In Operation Mode, T1/T2 can be updated regardless of the meter mode. In Simulation Mode, T1/T2 can only be updated while in simulation.

### 10.3. Setting and viewing tariff volumes

Tariff volumes can be set and view only via the IR interface. Only authorized users (admin level and above) may change them. Tariff volumes can only be set when the meter is unsealed.

One of three tariff update conditions can be active at a time:

- Volume mode (default value: 1000 m<sup>3</sup>)
- Time mode (default: 00:00 – 12:00)
- Flowrate mode (default threshold: 10,000 L/h)

Only one condition can be active at any time. The selected condition determines whether T1 or T2 is updated.

### 10.4. Volume mode

When the Volume Condition is active:

- A time window (default: 720 minutes) is defined.
- During the window, if the volume increase is below the threshold, T1 is updated.
- If the increase exceeds the threshold, T2 is updated.
- When the window ends, the counter resets, and T1 starts updating again.

### 10.5. Time mode

When the Time Condition is active:

- T1 is updated if flow occurs between two set times (e.g. 08:00–18:00).
- Outside this window, T2 is updated.
- If both times are equal (e.g., 12:00 and 12:00), T1 is never updated.

### 10.6. Flowrate mode

When the Flowrate Condition is active:

- T1 updates when flowrate is below the set threshold.
- T2 updates when flowrate is above it.
- Flowrate threshold is in L/h.

## 11. IR interface (optohead) and sonico® LIFE application

In addition to the NFC interfaces, the IR interface and an optical reading head can be used to communicate with the sonico® EDGE counter. This “optohead” can be connected to an Android tablet via Bluetooth interface. With the sonico® LIFE application software, the event history can be displayed and metrologically irrelevant parameters can be configured.

### 11.1. Activation of IR interface

The Bluetooth optical head contains an IR diode on one side and the Bluetooth interface for communication with a Bluetooth Android tablet on the other.



Fig. 24: Optohead (IR to Bluetooth)

Before using the optohead for the first time, charge it with the provided power supply cable. Make sure to switch off the device during charging.

The optohead can be plugged into a plastic cover with the infrared diode facing the meter display. To connect the optohead to the meter, insert it into the plastic holding cover contained in your order. Open the meter display lid and push the plastic cover containing the optohead onto the display cavity until the snaps fit in. Mind that the meter display lid needs to be at a 90° angle to the meter display in order to snap-in the cover, see Optohead fitted on the meter. Display lid is in a 90° angle to the meter display.

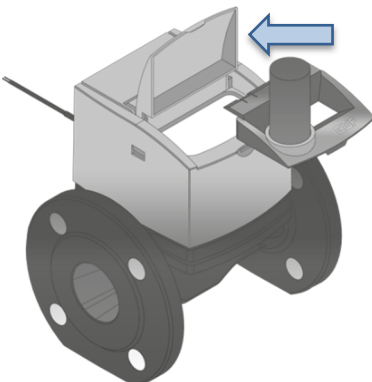

Fig. 25: Connecting the optohead in the holding cover to the meter

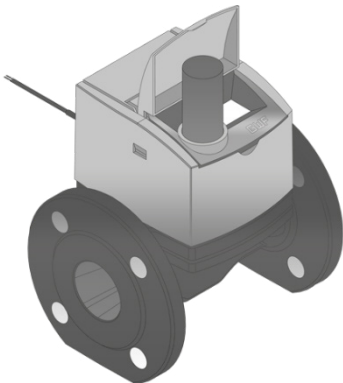

Fig. 26: Optohead fitted on the meter. Display lid is in a 90° angle to the meter display

Once the optical device is placed on the meter, switch on the reading head. The green status LED lights indicate that the optohead is ready for operation. Activate the Bluetooth function of your terminal device and connect to the optical interface.

When choosing to connect to the optohead with your terminal device, a password has to be entered. The factory-set Bluetooth password for the optohead is 0000.

### Information!



If the connection to the meter cannot be established or if there is an error message using sonico® LIFE, please turn the optohead by 45° inside the holder and try again to connect.

Disturbance by strong external lights do may influence the IR connection to the meter and shall be avoided.

## 11.2. Sonico® LIFE to enable legal meter information

The sonico® EDGE meter can be connected to an Android based device using the optical reading head and sonico® LIFE as described above. Sonico® LIFE can be used to access the legal meter functions and enables access to the history of the meter's legal metrology. This includes the firmware version, firmware update history and the event history.

The legal application also allows meter firmware updates. The sonico® EDGE legally relevant firmware can be updated three times in total. Unsuccessful attempts also count as an update. Furthermore, the device-specific key can be set with the legal application.

The GWF sonico® LIFE application including the legal function can be downloaded from google play store.

Updates of legal relevant firmware require approval from the legal body.

## 11.3. Removal of optohead

To remove the optohead cover, push the display lid back until the cover releases.

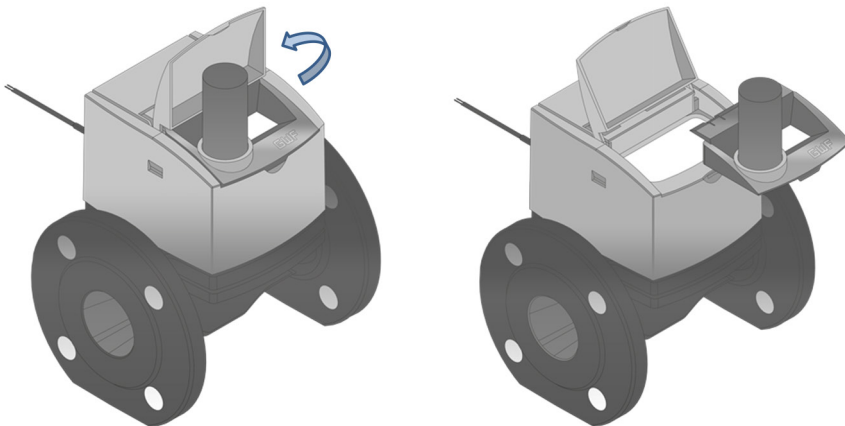

Fig. 27: Removal of optohead cover by pushing back display lid

Switch off the optohead after each communication session in order to save battery life of the device.

## 12. Communication modules

By default, if communication modules are ordered together with the meter, they will be attached to the respective NFC port upon delivery.

### Information!



Once a communication module is attached to the meter and connected to its endpoint, the radio symbol on the meter display is activated and the meter starts communicating.

As a standard, 3 m of power cable are connected to the sonico® EDGE communication modules upon delivery. Make sure to provide suitable additional length of cable and connect via the included IP68 cable connection.

## 12.1. Exchanging or adding communication modules

The three independent NFC communication slots of sonico® EDGE are designed such that communication modules can be readily exchanged or added during operation.

**Step 1:** Remove communication seal and open module lid, as shown in Fig. 28.

Using a screwdriver, destroy and remove the red communication seal on the meter head. Then push the screwdriver into the opening and slightly outward to unlock the snap-in connection holding the module cover in place. While pushing the screwdriver outward, the module lid can be opened by tilting it upwards from the backside of the meter.

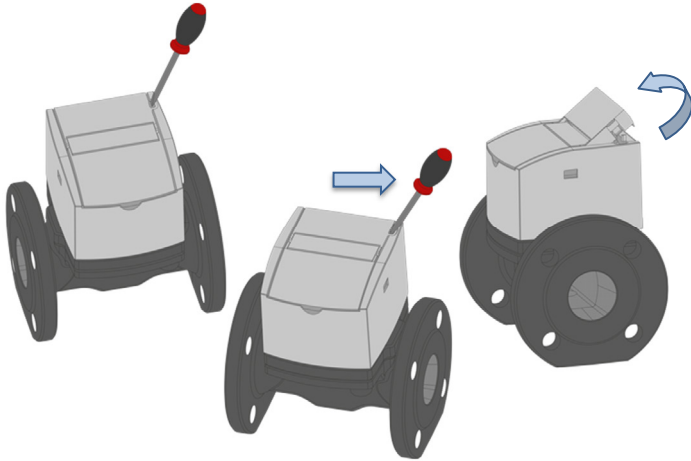

Fig. 28: Breaking of communication seal and lifting of module lid

**Step 2:** Exchange protective cover on the module lid, see Fig. 29.

If additional NFC modules shall be added to the meter, the protective cover on the module lid needs to be exchanged. Remove the cover from the opened module lid by pulling it outward as shown in Fig. 29. Separate module covers for one or two slots are available. If one module shall be placed on the meter, the two remaining slots need to be covered. If two modules are placed on the meter, only one remaining slot needs to be covered. Connect the suitable protective cover to the module lid such that the NFC slots on which a module will be placed remain uncovered. The cover will click in place when pushed onto the module lid.

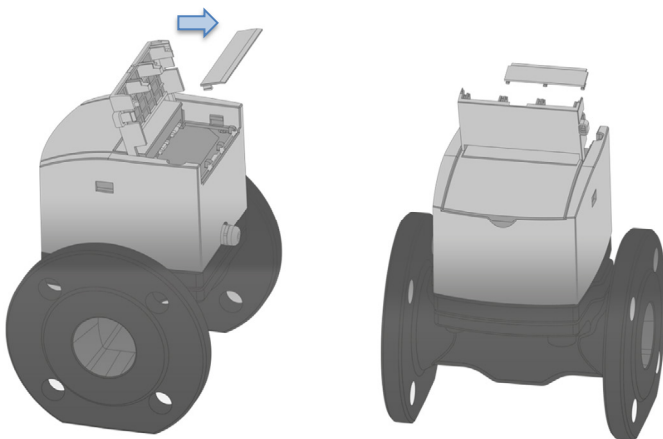

Fig. 29: Exchanging protective cover in order to add a new module

**Step 3:** Mounting of a communication module, as shown in Fig. 30.

The communication module can now be connected to the meter. The pulse module can be connected at both outer slots (no. 1 or 3) on the meter NFC interface. The module slot numbers 1-3 are engraved on the module lid. Insert the pulse module to slot 1 or 3 by pushing it down and connecting it to the two hooks placed in the frame. Now slide the module forward horizontally towards the front of the meter. The module should click into place and be firmly connected to the meter. Close the module lid and finally use a new communication seal.

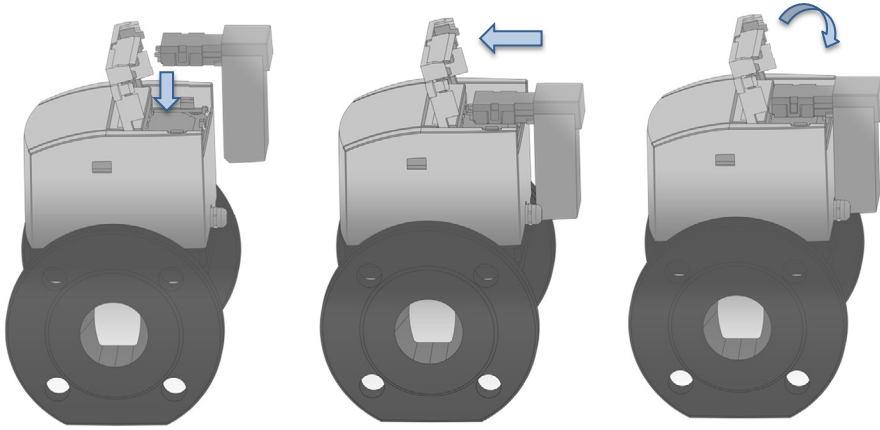

Fig. 30: Inserting module, pushing it into place and closing the module lid

**CAUTION**

**Caution**

After plug-in of the NFC modules, do not put any other NFC device near the device which may can disturb the communication between the device and the modules.

**12.2. Connection schematics communication modules**

The detailed connection schematics for the NFC communication modules (Pulse, 4-20 mA, ECO and Modbus) can be found online at the following link or QR code:



Module	Link to website	QR Link
Pulse module	<a href="https://productfinder.gwf.ch/en/puls-modul">https://productfinder.gwf.ch/en/puls-modul</a>	
4-20 mA module	<a href="https://productfinder.gwf.ch/en/4-20-ma-modul">https://productfinder.gwf.ch/en/4-20-ma-modul</a>	
ECO module	<a href="https://productfinder.gwf.ch/en/eco-e1-e2-modul">https://productfinder.gwf.ch/en/eco-e1-e2-modul</a>	
Modbus module	<a href="https://productfinder.gwf.ch/en/modbus-module">https://productfinder.gwf.ch/en/modbus-module</a>	

Table 4: Connection schematics communication modules

### 13. Error codes and troubleshooting

If the alarm flag appears, an error code will be shown in the display sequence as explained in chapter 8.3. The default threshold values of the respective errors are given in the table below. These values are factory set by the manufacturer. If an error message does not automatically reset (see table), it will have to be reset by a GWF specialist. This is especially important for the legally relevant errors "Air in Water" and "Internal Error (Malfunction)". Please contact your local representative for assistance.

Error Type	Error Code	Description*	Recommended Actions	Automatic Reset
Air in Water	E_L0002	Air in Water detected (Bubbles or Empty Pipe). This alarm will be reset as soon as the pipe is completely full, or the occurrence of bubbles disappears.	Flush pipe Check installation position and switch if necessary Check if cavitation occurred and reduce max. flow rate	Yes Alarm resets when no more air is detected
Burst Pipe	E_C0004	Max. defined flow rate ( $1.5 \times Q_4^*$ ) exceeded.	Check piping system	Yes Auto reset: 1 h
Leak detection	E_C0002	Flow rate never below min. set value.	Check piping system and valves	Yes Auto reset: 1 h
Reverse Flow	E_C0001	Reverse flow measured	Check correct installation. Change orientation of the meter	No
No Usage	E_C0008	Zero Flow over defined time (100d*) detected	Check piping system and valves Dismount meter and check for obstructions in the pipe, measurement channel or on the sensors Contact manufacturer for maintenance	Yes Auto reset: 1d
Water Temperature	E_C0010	Medium temperature is outside of a pre-determined temperature range (5 °C to 60 °C*) during a pre-determined time interval of 120 min.	Increase or reduce water temperature If integrated temperature sensor may have failed, contact manufacturer	No
Water Temperature	E_L0010	Water temperature measurement fails for 3 hours (either outside a predetermined range -10°C, 100°C-10 °C, 100 °C or PT1000 hardware failure or abnormal change between consecutive measurements), considering the default time interval (every 30 sec) for the temperature measurement.	Increase or reduce water temperature. If integrated temperature sensor may have failed, contact manufacturer.	No
Ambient Temperature	E_C0020	Ambient temperature is outside of a pre-determined temperature range (-10 °C to 70 °C*) during a pre-determined time interval of 120 min.	Protect installation from direct sunlight or cold temperatures and regulate ambient temperature If integrated temperature sensor may have failed, contact manufacturer.	No
Ambient Temperature	E_L0008	Electronics/Ambient temperature measurement fails for 3 hours (either outside a predetermined range -60°C, 140°C-60 °C, 140 °C or PT1000 hardware failure or abnormal change between consecutive measurements), considering the default time interval (every 30 sec) for the temperature measurement.	Protect installation from direct sunlight or cold temperatures and regulate ambient temperature. If integrated temperature sensor may have failed, contact manufacturer.	No
No External Supply	E_C0040	External power disconnected	Check cables, fuses and power supply Check voltage level (must be from 19.2 to 26.4 V DC)	No
Internal Error (Malfunction)	E_L0001	General internal error	Contact GWF for assistance and reset	No
Sensor Error	E_L0020	Sensor failure	Contact GWF for assistanc	No
Sensor Error	E_L0040	External flash malfunction	Contact GWF for assistanc	No

Table 5: Error types and codes and their standard thresholds

\* All parameters are default factory alarm threshold values.

## 14. Dismounting and disposal

### 14.1. Dismounting



#### WARNING

#### Warning

Disconnect power before dismantling the device.

- Check if the pipe is empty.
- Disconnect meter and communication modules from power supply.
- Loosen the bolts and carefully remove meter from pipe.
- Remove flange gaskets.

### 14.2. Disposal



#### CAUTION



#### Caution

Dispose the device in compliance with your country's legal and valid regulations for the disposal of electronic and electrical appliances.

Correct disposal avoids negative effects on public health and the environment and ensures recycling of valuable raw materials.

This symbol indicates that the directive 2012/19/EU (WEEE) on waste and electronic equipment requirements shall be observed upon disposal of the device.

### 14.3. Recycling

This product contains a lithium ion battery. In order to protect the environment, this device may not be disposed in regular household waste after the end of its lifetime. Any local and national regulations for environmental protection shall be considered.

#### 14.3.1. Product recycling and disposal (Europe only)



Electrical equipment marked with the above symbol may not be disposed of in European public disposal systems as of 12 August 2005. According to European local and national regulations (EU Directive 2012/19/EU), European electrical equipment users may return old or end-of-life equipment to the manufacturer for disposal or recycling at no charge. GWF is committed to minimize the risk of any environmental damage or pollution caused by any of its products.



#### Information!

For return or recycling, please contact GWF or your local supplier for detailed instructions.

### 14.4. Return / Repair

Please follow the following instructions in case the device shall be returned to GWF for repair or inspection:

- Download the return form on the official GWF website in the support section.
- Fill in the form and include the completed form with your return shipment.
- Send the device with proper declaration of hazardous material. A suitable warning label according to 'UN3481 PI 967 Sec II' must be attached to the packaging and remain visible on the outside of the package.
- Pack the meter safely, ideally by using the original packing.
- Send the parcel to GWF, Obergrundstrasse 119, 6005 Lucerne, Switzerland, for repair.

## 15. Technical data and certification

### 15.1. Metrological data

Nominal flow rate	DN	mm	50	65	80	100	125	150	200	250	300
$Q_3 / Q_1$			1000	1000	1000	1000	1000	1000	1000	1000	1000
Starting flow rate	$Q_{start}$	l/h	25	40	50	80	150	200	300	450	600
	$V_{start}$	m/s	0.0047	0.0053	0.0042	0.0042	0.0050	0.0045	0.0040	0.0060	0.0050
Minimum flow rate $\pm 5\%$	$Q_1$	m <sup>3</sup> /h	0.04	0.063	0.1	0.16	0.16	0.4	0.63	0.63	1
	V1	m/s	0.0076	0.0084	0.0084	0.0083	0.0083	0.0089	0.0084	0.0084	0.0084
Transitional flow rate $\pm 2\%$	$Q_2$	m <sup>3</sup> /h	0.064	0.101	0.16	0.256	0.256	0.64	1	1	1.6
	V2	m/s	0.012	0.013	0.013	0.013	0.013	0.014	0.013	0.013	0.013
Nominal flow rate $\pm 2\%$	$Q_3$	m <sup>3</sup> /h	40	63	100	160	160	400	630	630	1000
	V3	m/s	7.57	8.39	8.41	8.35	8.35	8.91	8.37	8.37	8.35
Overload flow rate	$Q_4$	m <sup>3</sup> /h	50	75.6	125	200	200	500	787.5	787.5	1250
	V4	m/s	9.47	10.06	10.51	10.44	10.44	11.14	10.46	10.46	10.44
Maximal flow rate	$Q_{max}$	m <sup>3</sup> /h	90	140	200	300	300	600	1100	1100	2000
	$V_{max}$	m/s	17.04	18.63	16.82	15.66	15.66	13.37	14.61	14.61	16.71
Nominal pressure	PN	bar	16	16	16	16	16	16	16	16	16

Table 6: Metrological data of sonico® EDGE flow meters

### 15.2. Environmental specifications and certification

- Mechanical Environmental Class MI-001: M2; OIML R49: M2
- Electromagnetic Environmental Class MI-001: E2; OIML R49: E2
- Ambient storage temperature -20 °C to +70 °C
- Ambient operating temperature -20 °C to +70 °C
- Protection class IP68 according to EN 60529
- Protection against EMC levels according to ISO 4064

All relevant conformity certificates can be downloaded from the GWF website ([www.gwf.ch](http://www.gwf.ch)) in the product finder section.

## 15.3. EU declaration of conformity

# GWF



## EU Konformitätserklärung EU Declaration of conformity

**Hersteller**  
*Manufacturer*

GWF MessSysteme AG  
Obergrundstrasse 119  
CH-6002 Luzern  
Schweiz / Switzerland

**Produkt**  
*Product*

Wasserzähler - Ultraschall  
*Water meter - Ultrasonic*

**Typ, Ausführung**  
*Type, model*

sonico EDGE

**Produkt Kennzeichnung**  
*Product marking*

 Mxx 1259  
TCM 142/20 - 5721

**EU-Richtlinie**  
*EU Directives*

2014/32/EU – MID

**Normen**  
*Normative*

EN ISO 4064-1:2017, R49-1:2013

**Bauartprüfzertifikat**  
*Type examination*

TCM 142/20 - 5721  
MID – 2014/32/EU Anhang II, Modul B / *Annex II, module B*  
Czech Metrology Institute  
CZ-638 00 Brno  
Benannte Stelle 1383 / *Notified Body 1383*

**Überwachungsverfahren**  
*Surveillance procedure*

2014/32/EU Anhang II, Modul D / *Annex II, module D*  
Eidgenössisches Institut für Metrologie, METAS-Cert  
CH-3003 Bern-Wabern  
Benannte Stelle 1259 / *Notified Body 1259*

### Wir erklären als Hersteller:

Die entsprechend gekennzeichneten Produkte sind nach den aufgeführten Richtlinien und Normen hergestellt. Sie stimmen mit dem geprüften Baumuster überein. Die Herstellung unterliegt dem genannten Überwachungsverfahren.

### We declare as manufacturer:

Products labelled accordingly are manufactured according of the listed Directives and Standards. They correspond to the tested type samples. The production is subject to the stated surveillance procedure.

**Ort und Datum**  
*Place and date*

Luzern, 01.05.2020

**Dr. Markus Helfenstein**  
Geschäftsführer R&D  
EVP R&D

**Urs Imholz**  
Geschäftsführer Schweiz  
EVP Switzerland

## 16. Spare parts and accessories

### 16.1. Available accessories

- IR communication kit including optohead, optohead holding frame and charging cable.

### 16.2. Communication modules

Communication modules as a spare part can be ordered directly from GWF. Please contact your local GWF representative for further technical information. The exchange or additional installation of communication modules to a sonico® EDGE meter is described in chapter 12.1.

### 16.3. Spare parts

- Flange gaskets
- Communication seal as described in chapter 3.3
- Display lid
- Module lid and module protective cover
- Flange connection bolts

# 17. Annex

## 17.1. Checklists

### 17.1.1. Checklist incoming acceptance ←

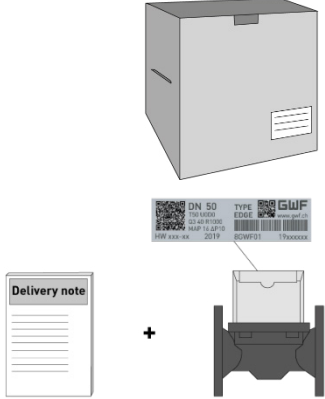
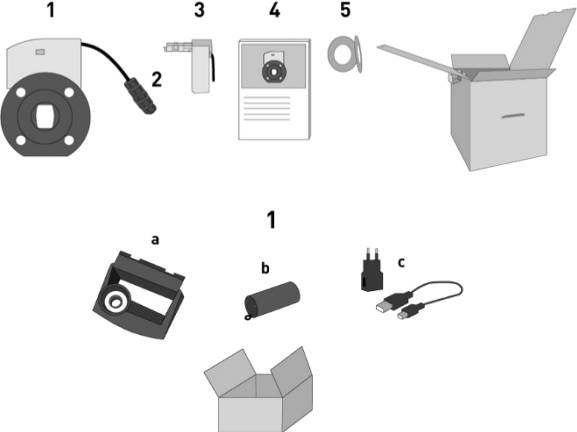
<p>Is the delivery undamaged?</p>	
<p>Does the order information on the packaging correspond to the delivery note?</p> <p>Do the details on the meter nameplate match the delivery note and your order?</p>	
<p>Is the scope of delivery complete, including any accessories?</p>	

### 17.1.2. Checklist installation preparation ←

<b>Required tools</b>	
Two spanners for the corresponding size of bolts	
Wrench for cable glands	
Torque wrench for installing flow meter in pipeline	
Optionally: Hoisting devices	
Check the following:	
Are the gaskets correctly aligned with the flange?	
Are water and environmental temperatures within specifications?	
Is the pressure rating corresponding to the one printed on the meter body?	

### 17.1.3. Checklist electrical connection: tools and requirements ←

<b>Required tools</b>	
Sonico® power supply cable extension	
Screwdriver	
Wire stripper	
When using stranded cables: Crimper for wire end ferrule	
Check the following:	
Is your power supply cable in accordance with federal/national regulations and suitable for min. and max. temperatures to be expected?	

### 17.1.4. Checklist electrical connection: final inspection ←

<b>Check the following:</b>	
Are transmitters, cables, sensors and cable glands undamaged?	
Is the housing properly fitted, clean and undamaged?	
Are all cable glands tightened?	
Are the mounted cables strain relieved and unbent?	

## 17.2. Document revision history

This version of the document replaces all previous versions.

Date	Modifications and comments	Rev. No. user manual
06.01.2020	1. release	01/2020
03.05.2021	2. release	05/2021
03.12.2021	3. release	12/2021
01.03.2023	4. release	03/2023
11.08.2023	5. release	08/2023
31.08.2023	6. release	09/2023
12.01.2024	7. release	01/2024
01.01.2025	8. release	01/2025
08.06.2025	9. release (New Layout) Added chapter 9 and 10	05/2025
19.08.2025	10. release Changes in Chapter 13	08/2025
23.02.2026	11. release New QR-Codes and Links in Chapter 12.2	02/2026



**GWF AG**

Obergrundstrasse 119  
6005 Lucerne, Switzerland

T +41 41 319 50 50  
info@gwf.ch

Copyright © 2026 GWF AG

All rights reserved. No part of this documentation may be reproduced in any form, stored, or transferred, neither electronically, mechanically, photo-technically, by recording on data media, still otherwise, as long as no expressly written authorization of the publisher is present.

We reserve the right, to change the described products without prior notice. This publication can be updated and modified without prior notice.

02/2026 – BAe10230

→ [gwf.ch](https://www.gwf.ch)